



DESCRIPTION

The A7221B is a fully integrated, high-efficiency 2A synchronous rectified step-down converter. The A7221B operates at high efficiency over a wide output current load range.

This device offers two operation modes, PWM control and PFM Mode switching control, which allows a high efficiency over the wider range of the load.

The A7221B is available in SOT-26 package.

ORDERING INFORMATION

Package Type	Part Number	
SOT-26	E6	A7221BE6R
		A7221BE6VR
Note	V: Halogen free Package R: Tape & Reel SPQ:3,000pcs/Reel	
AiT provides all RoHS products Suffix " V " means Halogen free Package		

FEATURES

- High Efficiency: Up to 96%
- 600kHz Frequency Operation
- 2A Output Current
- No Schottky Diode Required
- 3.5V to 16V Input Voltage Range
- 0.6V Reference
- Slope Compensated Current Mode Control for Excellent Line and Load Transient Response
- Integrated internal compensation
- Stable with Low ESR Ceramic Output Capacitors
- Over Current Protection with Hiccup-Mode
- Thermal Shutdown
- Inrush Current Limit and Soft Start
- -40°C to +85°C Temperature Range
- Available in SOT-26 Package

APPLICATION

- Distributed Power Systems
- Digital Set Top Boxes
- Flat Panel Television and Monitors
- Wireless and DSL Modems
- Notebook Computer

TYPICAL APPLICATION

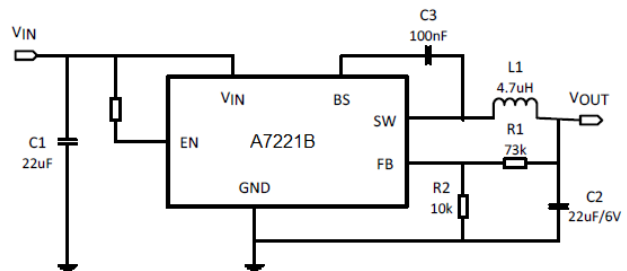



PIN DESCRIPTION

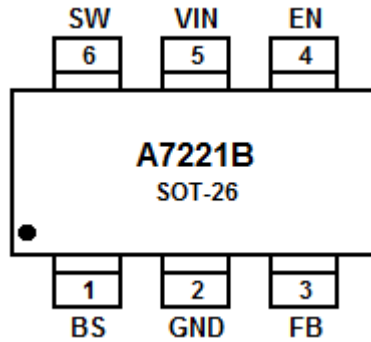

Top View

Pin #	Symbol	Function
1	BS	Bootstrap. A capacitor connected between SW and BS pins is required to form a floating supply across the high-side switch driver.
2	GND	Ground
3	FB	Adjustable version feedback input. Connect FB to the center point of the external resistor divider.
4	EN	Drive this pin to a logic-high to enable the IC. Drive to a logic-low to disable the IC and enter micro-power shutdown mode.
5	V _{IN}	Power supply Pin
6	SW	Switching Pin



ABSOLUTE MAXIMUM RATINGS

V_{IN} , Supply Voltage	-0.3V ~ 25V
V_{SW} , Switch Node Voltage	-0.3V ~ ($V_{IN}+0.5V$)
V_{BS} , Boost Voltage	$V_{SW}-0.3V \sim V_{SW}+5V$
All Other Pins	-0.3V ~ 6V
Operating Temperature Range	-40°C ~ 85°C
Storage Temperature Range	-65°C ~ 150°C
Lead Temperature (Soldering,10s)	300°C

Stress beyond above listed "Absolute Maximum Ratings" may lead permanent damage to the device. These are stress ratings only and operations of the device at these or any other conditions beyond those indicated in the operational sections of the specifications are not implied. Exposure to absolute maximum rating conditions for extended periods may affect device reliability.

ELECTRICAL CHARACTERISTICS

$V_{IN} = 12V$, $V_{OUT} = 5V$, $T_A = 25^\circ C$, unless otherwise stated

Parameter	Conditions	Min.	Typ.	Max.	Unit
Input Voltage Range		3.5		16	V
UVLO Threshold			2		V
Supply Current in Operation	$V_{EN} = 2.0V$, $V_{FB} = 1.1V$		0.4	0.6	mA
Supply Current in Shutdown	$V_{EN} = 0V$ or $V_{EN} = GND$		1		μA
Regulated Feedback Voltage	$4.5V < V_{IN} < 16V$	0.588	0.6	0.612	V
High-side Switch On Resistance			90		m Ω
Low-side Switch On Resistance			70		m Ω
High-side Switch Leakage Current	$V_{EN} = 0V$, $V_{SW} = 0V$		0	10	μA
Upper Switch Current Limit	Minimum Duty Cycle		4.2		A
Oscillation Frequency			600		kHz
Maximum Duty Cycle	$V_{FB} = 0.6V$		92		%
Minimum On Time			60		ns
Thermal Shutdown			170		$^\circ C$



TYPICAL PERFORMANCE CHARACTERISTICS

Tested under, $L=4.7\mu\text{H}$, $T_A = 25^\circ\text{C}$, unless otherwise specified

1. Efficiency vs. I_{OUT} ($V_{\text{OUT}} = 1.2\text{V}$)

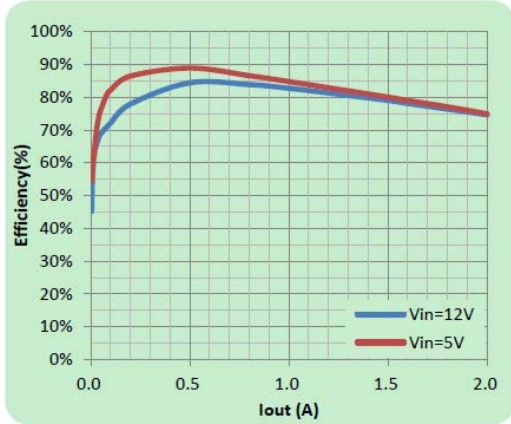

2. Efficiency vs. I_{OUT} ($V_{\text{OUT}} = 3.3\text{V}$)

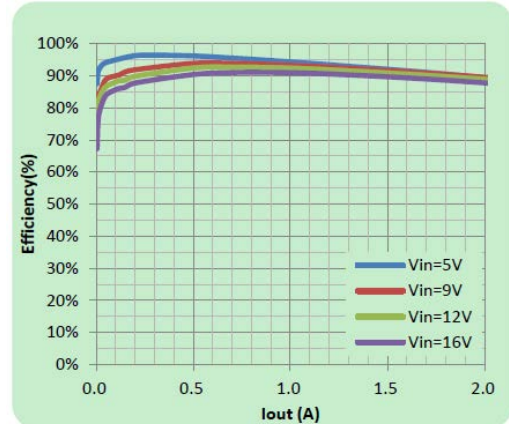

3. Efficiency vs. I_{OUT} ($V_{\text{OUT}} = 5.0\text{V}$)

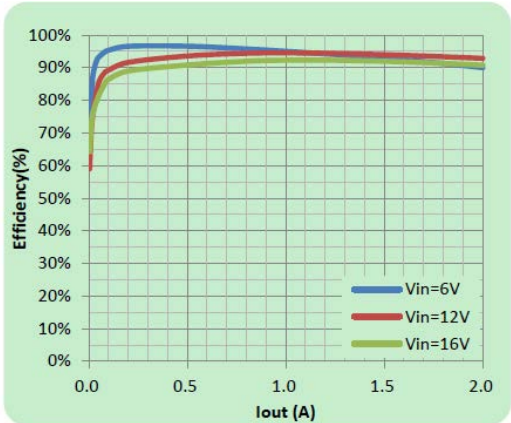

4. V_{OUT} vs. I_{OUT} ($V_{\text{OUT}} = 1.2\text{V}$)

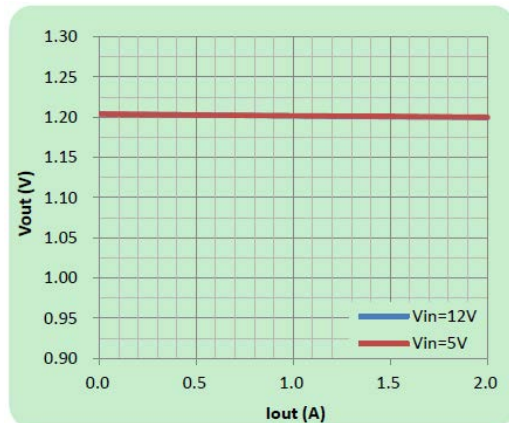

5. V_{OUT} vs. I_{OUT} ($V_{\text{OUT}} = 3.3\text{V}$)

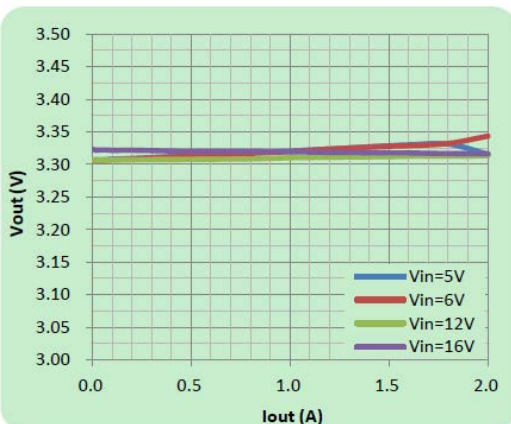

6. V_{OUT} vs. I_{OUT} ($V_{\text{OUT}} = 5.0\text{V}$)

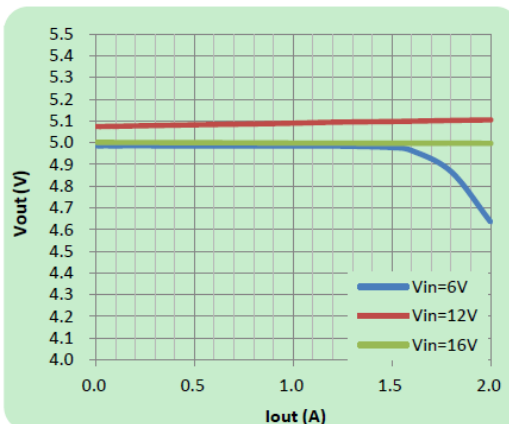



7. Efficiency vs. V_{in} ($I_{out} = 1A$)

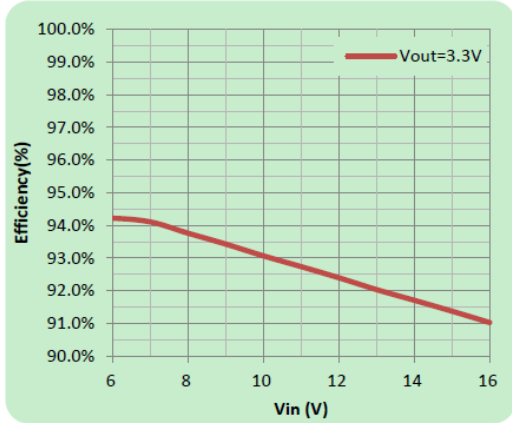

8. V_{out} vs. V_{in} ($I_{out} = 1A$)

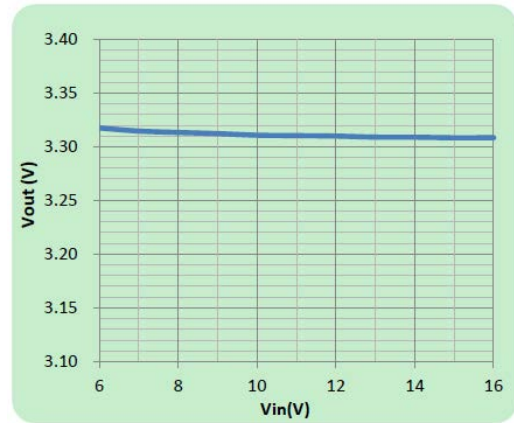

BLOCK DIAGRAM

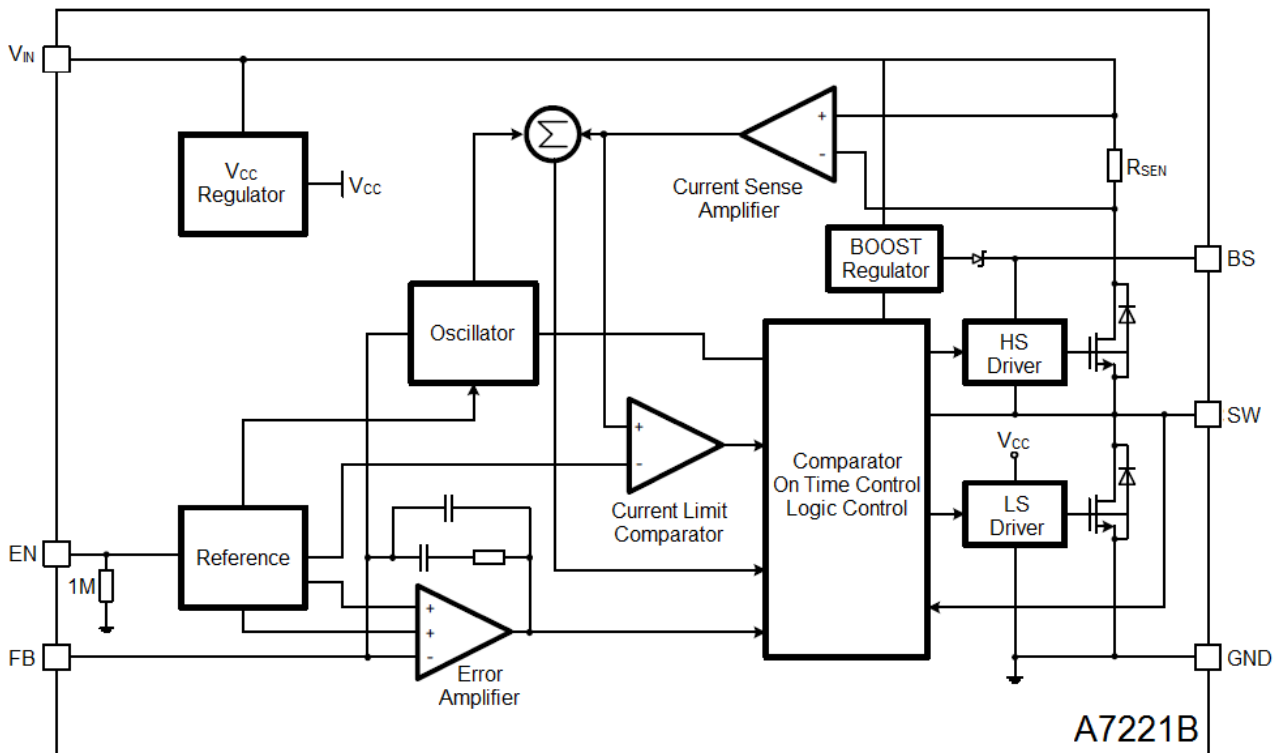



DETAILED INFORMATION

Internal Regulator

The A7221B is a current mode step down DC/DC converter that provides excellent transient response with no extra external compensation components. This device contains an internal, low resistance, high voltage power MOSFET, and operates at a high 600k operating frequency to ensure a compact, high efficiency design with excellent AC and DC performance.

Error Amplifier

The error amplifier compares the FB pin voltage with the internal FB reference (V_{FB}) and outputs a current proportional to the difference between the two. This output current is then used to charge or discharge the internal compensation network to form the COMP voltage, which is used to control the power MOSFET current. The optimized internal compensation network minimizes the external component counts and simplifies the control loop design.

Internal Soft-Start

The soft-start is implemented to prevent the converter output voltage from overshooting during startup. When the chip starts, the internal circuitry generates a soft-start voltage (SS) ramping up from 0V to 0.6V. When it is lower than the internal reference (REF), SS overrides REF so the error amplifier uses SS as the reference. When SS is higher than REF, REF regains control. The SS time is internally fixed to 1ms.

Over-Current-Protection and Hiccup

The A7221B has cycle-by-cycle over current limit when the inductor current peak value exceeds the set current limit threshold. Meanwhile, output voltage starts to drop until FB is below the Under-Voltage (UV) threshold, typically 30% below the reference. Once a UV is triggered, the A7221B enters hiccup mode to periodically restart the part. This protection mode is especially useful when the output is dead-short to ground. The average short circuit current is greatly reduced to alleviate the thermal issue and to protect the regulator. The A7221B exits the hiccup mode once the over current condition is removed.

Startup and Shutdown

If both V_{IN} and EN are higher than their appropriate thresholds, the chip starts. The reference block starts first, generating stable reference voltage and currents, and then the internal regulator is enabled. The regulator provides stable supply for the remaining circuitries. Three events can shut down the chip: EN low, V_{IN} low and thermal shutdown. In the shutdown procedure, the signaling path is first blocked to avoid any fault triggering. The COMP voltage and the internal supply rail are then pulled down. The floating driver is not subject to this shutdown command.



APPLICATIONS INFORMATION

Setting Output Voltages

The external resistor divider is used to set the output voltage (see Typical Application on page 1). The feedback resistor R1 also sets the feedback loop bandwidth with the internal compensation capacitor. Choose R1 to be around 100kΩ for optimal transient response. R2 is then given by:

$$R_2 = \frac{R_1}{V_{OUT}/V_{FB} - 1}$$

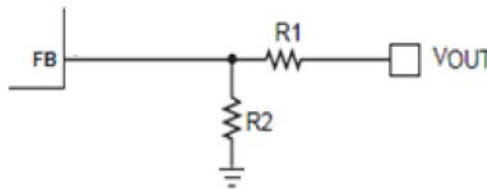

Selecting the Inductor

A 4.7μH to 22μH inductor with a DC current rating of at least 25% percent higher than the maximum load current is recommended for most applications. For highest efficiency, the inductor DC resistance should be less than 15mΩ. For most designs, the inductance value can be derived from the following equation.

$$L = \frac{V_{OUT} \times (V_{IN} - V_{OUT})}{V_{IN} \times \Delta I_L \times f_{OSC}}$$

Where ΔI_L is the inductor ripple current. Choose inductor ripple current to be approximately 30% if the maximum load current, 2A. The maximum inductor peak current is:

$$I_{L(MAX)} = I_{LOAD} + \frac{\Delta I_L}{2}$$

Under light load conditions below 100mA, larger inductance is recommended for improved efficiency.

Selecting the Output Capacitor

The output capacitor (C2) is required to maintain the DC output voltage. Ceramic, tantalum, or low ESR electrolytic capacitors are recommended. Low ESR capacitors are preferred to keep the output voltage ripple low. The output voltage ripple can be estimated by:

$$\Delta V_{OUT} = \frac{V_{OUT}}{f_s \times L} \times \left[1 - \frac{V_{OUT}}{V_{IN}} \right] \times \left[R_{ESR} + \frac{1}{8 \times f_s \times C_2} \right]$$

Where L is the inductor value and R_{ESR} is the equivalent series resistance (ESR) value of the output capacitor. In the case of ceramic capacitors, the impedance at the switching frequency is dominated by the capacitance. The output voltage ripple is mainly caused by the capacitance. For simplification, the output voltage ripple can be estimated by:

$$\Delta V_{OUT} = \frac{V_{OUT}}{8 \times f_s^2 \times L \times C_2} \times \left[1 - \frac{V_{OUT}}{V_{IN}} \right]$$



In the case of tantalum or electrolytic capacitors, the ESR dominates the impedance at the switching frequency. For simplification, the output ripple can be approximated to:

$$\Delta V_{OUT} = \frac{V_{OUT}}{f_S \times L} \times \left[1 - \frac{V_{OUT}}{V_{IN}} \right] \times R_{ESR}$$

The characteristics of the output capacitor also affect the stability of the regulation system. The A7221B can be optimized for a wide range of capacitance and ESR values.



PACKAGE INFORMATION

Dimension in SOT-26 Package (Unit: mm)

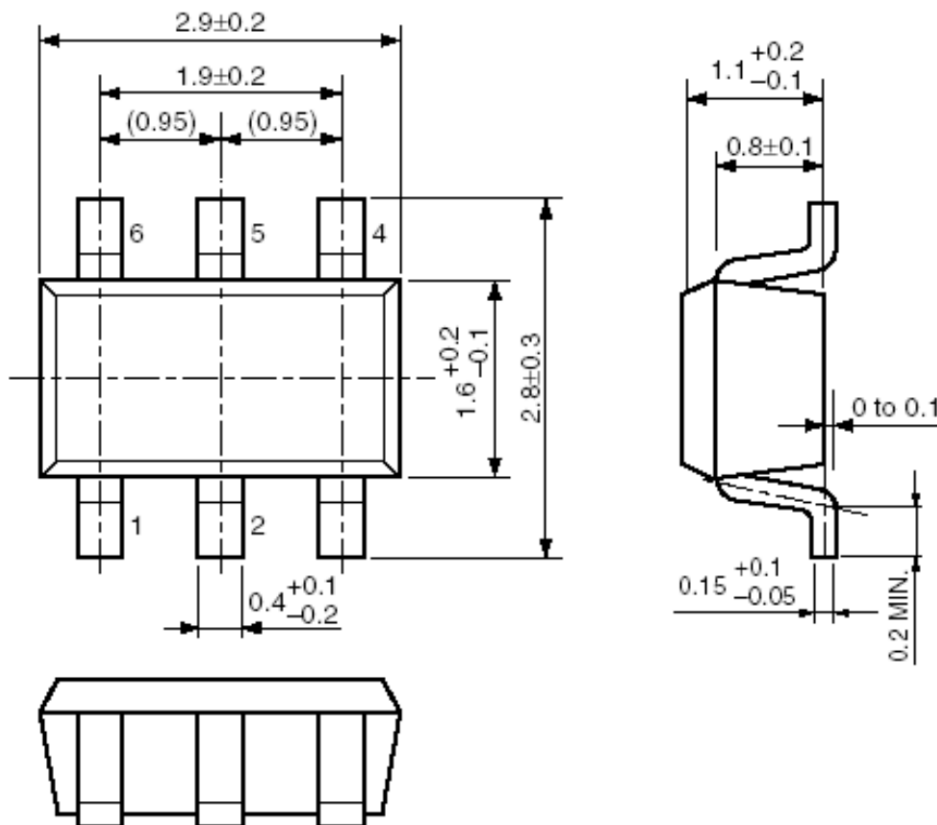



IMPORTANT NOTICE

AiT Semiconductor Inc. (AiT) reserves the right to make changes to any its product, specifications, to discontinue any integrated circuit product or service without notice, and advises its customers to obtain the latest version of relevant information to verify, before placing orders, that the information being relied on is current.

AiT Semiconductor Inc.'s integrated circuit products are not designed, intended, authorized, or warranted to be suitable for use in life support applications, devices or systems or other critical applications. Use of AiT products in such applications is understood to be fully at the risk of the customer. As used herein may involve potential risks of death, personal injury, or severe property, or environmental damage. In order to minimize risks associated with the customer's applications, the customer should provide adequate design and operating safeguards.

AiT Semiconductor Inc. assumes to no liability to customer product design or application support. AiT warrants the performance of its products of the specifications applicable at the time of sale.

www.s-manuals.com