



DESCRIPTION

The A7231 is a current mode monolithic buck voltage converter. Operating with an input range of 4.5V-18V, the A7231 delivers 3A of continuous output current with two integrated N-Channel MOSFETs. At light loads, regulators operate in low frequency to maintain high efficiency and low output ripple.

The A7231 guarantees robustness with over current protection, thermal protection, start-up current run-away protection, and input under voltage lockout.

The A7231 is available in TSOT-26 package.

ORDERING INFORMATION

Package Type	Part Number	
TSOT-26	TE6	A7231TE6R
		A7231TE6VR
Note	V: Halogen free Package R: Tape & Reel	
AiT provides all RoHS products Suffix " V " means Halogen free Package		

FEATURES

- 4.5V to 18V operating input range
- 3A output current
- Up to 95% efficiency
- High efficiency at light load
- Fixed 420kHz Switching frequency
- Input under voltage lockout
- Start-up current run-away protection
- Over current protection and Hiccup
- Thermal protection
- Available in TSOT-26 Package

APPLICATION

- Distributed Power Systems
- Networking Systems
- FPGA, DSP, ASIC Power Supplies
- Green Electronics/ Appliances
- Notebook Computers

TYPICAL APPLICATION

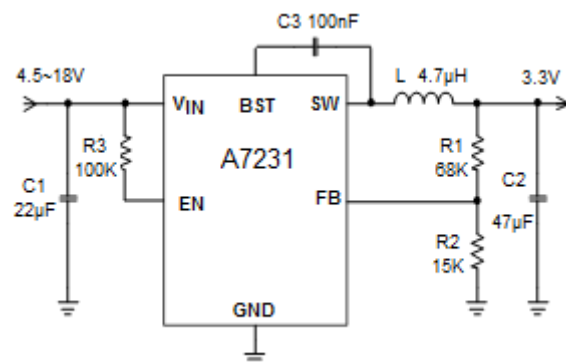

3A Buck Voltage Converter



PIN DESCRIPTION

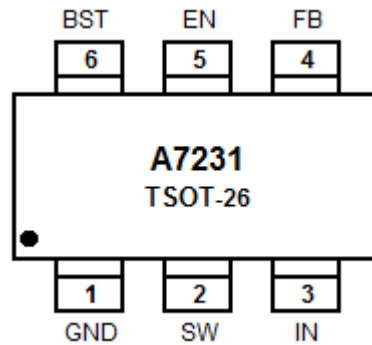

Top View

Pin #	Symbol	Function
1	GND	Power ground pin.
2	SW	SW is the switching node that supplies power to the output. Connect the output LC filter from SW to the output load.
3	IN	Input voltage pin. V_{IN} supplies power to the IC. Connect a 4.5V to 18V supply to V_{IN} and bypass V_{IN} to GND with a suitably large capacitor to eliminate noise on the input to the IC.
4	FB	Output feedback pin. FB senses the output voltage and is regulated by the control loop to 0.6V. Connect a resistive divider at FB.
5	EN	Drive EN pin high to turn on the regulator and low to turn off the regulator.
6	BST	Bootstrap pin for top switch. A 0.1 μ F or larger capacitor should be connected between this pin and the SW pin to supply current to the top switch and top switch driver.



ABSOLUTE MAXIMUM RATINGS

V_{IN} , EN, SW PIN	-0.3V ~ 19V
BST PIN	SW-0.3V to SW+5V
FB PIN	-0.3V to 2.5V
Junction Temperature ^{NOTE1,2}	150°C
Lead Temperature	260°C
Storage Temperature	-65°C ~ +150°C

Stress beyond above listed "Absolute Maximum Ratings" may lead permanent damage to the device. These are stress ratings only and operations of the device at these or any other conditions beyond those indicated in the operational sections of the specifications are not implied. Exposure to absolute maximum rating conditions for extended periods may affect device reliability.

NOTE1: The A7231 guarantees robust performance from -40°C to 150°C junction temperature. The junction temperature range specification is assured by design, characterization and correlation with statistical process controls.

NOTE2: The A7231 includes thermal protection that is intended to protect the device in overload conditions. Thermal protection is active when junction temperature exceeds the maximum operating junction temperature. Continuous operation over the specified absolute maximum operating junction temperature may damage the device.

RECOMMENDED OPERATING CONDITIONS

Parameter	Symbol	Min	Max	Units
Input Voltage	V_{IN}	4.5	18	V
Output Voltage	V_{OUT}	0.8	16.2	V
Junction Temperature	T_J	-40	125	°C

THERMAL PERFORMANCE^{NOTE3}

Package	θ_{JA}	θ_{JC}
TSOT-26	110°C/W	55°C/W

NOTE3: Measured on JESD51-7, 4-layer PCB.



ELECTRICAL CHARACTERISTICS

$V_{IN}=12V$, $T_A=25^{\circ}C$, unless otherwise stated.

Parameter	Symbol	Conditions	Min.	Typ.	Max.	Unit
V_{IN} Undervoltage Lockout Threshold	V_{IN_MIN}	V_{IN} falling		3.9	4.1	V
V_{IN} Undervoltage Lockout Hysteresis	$V_{IN_MIN_HYST}$	V_{IN} rising		250		mV
Shutdown Supply Current	I_{SD}	$V_{EN}=0V$		0.2	0.3	μA
Supply Current	I_Q	$V_{EN}=5V$, $V_{FB}=2V$		80	100	μA
Feedback Voltage	V_{FB}		588	600	612	mV
Top Switch Resistance ^{NOTE4}	$R_{DS(ON)T}$			115		m Ω
Bottom Switch Resistance ^{NOTE4}	$R_{DS(ON)B}$			71		m Ω
Top Switch Leakage Current	I_{LEAK_TOP}	$V_{IN}=16V$, $V_{EN}=0V$, $V_{SW}=0V$			0.5	μA
Bottom Switch Leakage Current	I_{LEAK_BOT}	$V_{IN}=16V$, $V_{EN}=0V$, $V_{SW}=0V$			0.5	μA
Top Switch Current Limit ^{NOTE4}	I_{LIM_TOP}	Minimum Duty Cycle		5.5		A
Switch Frequency	F_{SW}			420		kHz
Minimum On Time ^{NOTE4}	T_{ON_MIN}			100		ns
Minimum Off Time ^{NOTE4}	T_{OFF_MIN}	$V_{FB}=0.7V$		130		ns
EN Shut Down Threshold Voltage	V_{EN_TH}	V_{EN} falling, $FB=0V$		1.2		V
EN Shut Down Hysteresis	V_{EN_HYST}	V_{EN} rising, $FB=0V$		100		mV
Thermal Shutdown ^{NOTE4}	T_{TSD}			145		$^{\circ}C$
Temperature Hysteresis ^{NOTE4}	T_{HYS}			20		$^{\circ}C$

NOTE4: Guaranteed by design.



TYPICAL PERFORMANCE CHARACTERISTICS

$V_{IN} = 12V$, $V_{OUT} = 3.3V$, $L = 4.7\mu H$, $C_{OUT} = 47\mu F$, $T_A = +25^\circ C$, unless otherwise noted

1. Steady State Test

$V_{IN} = 12V$, $V_{OUT} = 3.3V$, $I_{OUT} = 3A$

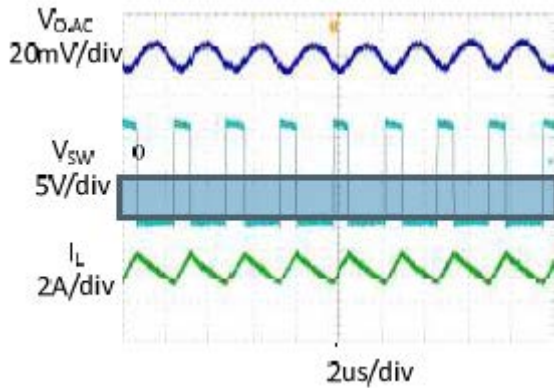

2. Startup through Enable

$V_{IN} = 12V$, $V_{OUT} = 3.3V$, $I_{OUT} = 3A$ (Resistive load)

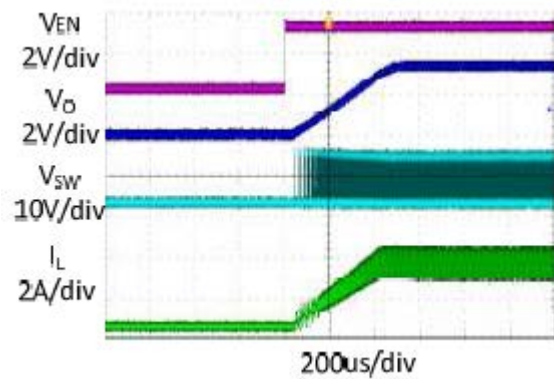

3. Shutdown through Enable

$V_{IN} = 12V$, $V_{OUT} = 3.3V$, $I_{OUT} = 3A$ (Resistive load)

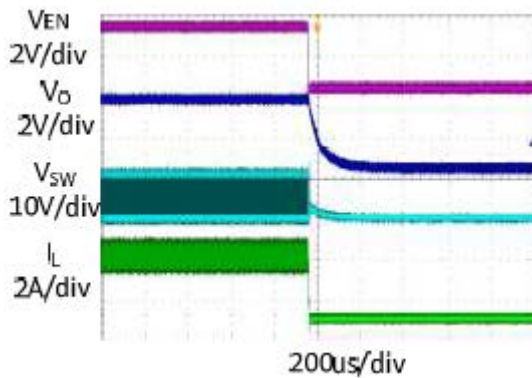

4. Heavy Load Operation

2A LOAD

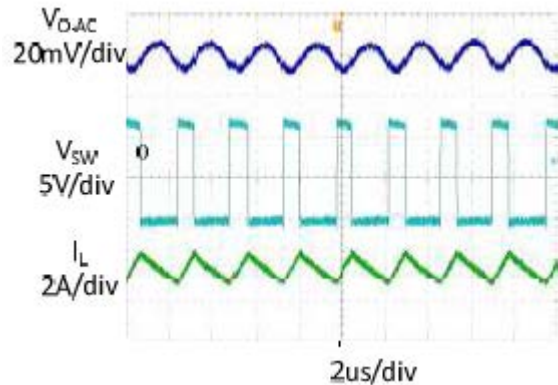

5. Medium Load Operation

1A LOAD

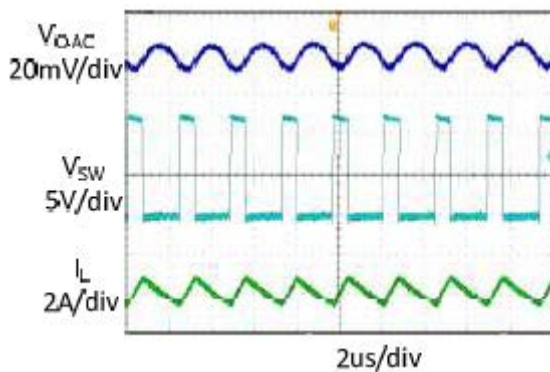

6. Light Load Operation

0 A LOAD

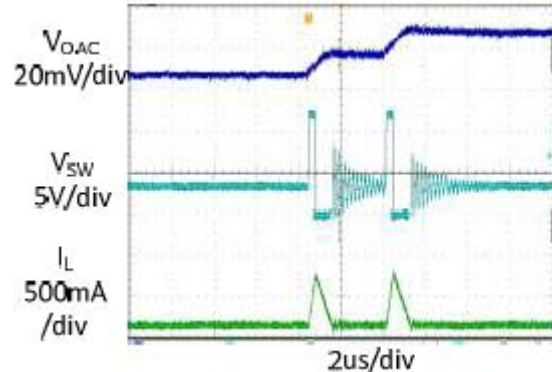



7. Short Circuit Protection

$V_{IN}=12V$, $V_{OUT}=3.3V$, $I_{OUT}=3A$ - Short

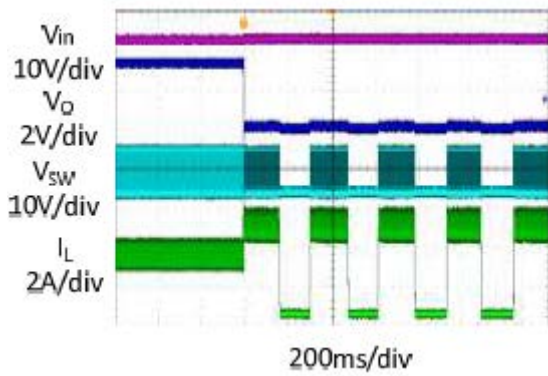

8. Short Circuit Recovery

$V_{IN}=12V$, $V_{OUT}=3.3V$, I_{OUT} = Short-3A

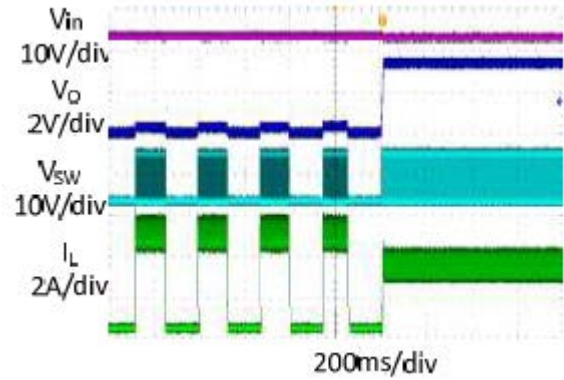

9. Load Transient

1.5A LOAD → 3A LOAD → 1.5A LOAD

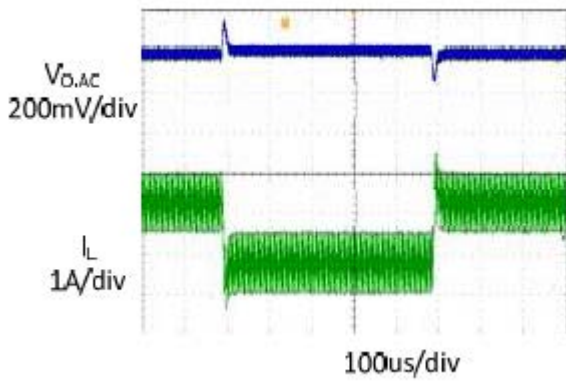

10. Quiescent Current vs. Temp

$V_{IN}=12V$, $V_{OUT}=3.3V$, $V_{EN}=2.5V$, $V_{FB}=0.8V$

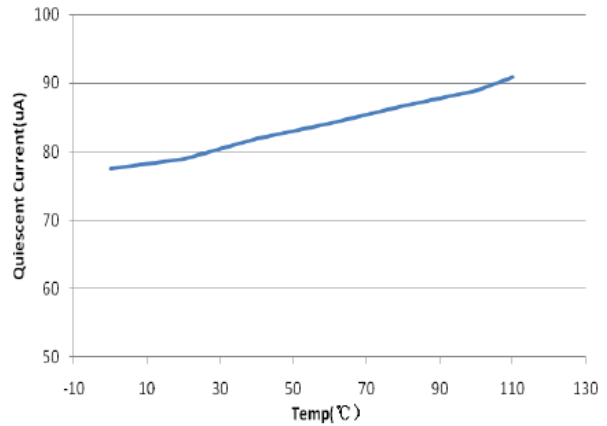

11. Quiescent Current vs. Input Voltage

$V_{IN}=12V$, $V_{OUT}=3.3V$, $V_{EN}=2.5V$, $V_{FB}=0.8V$

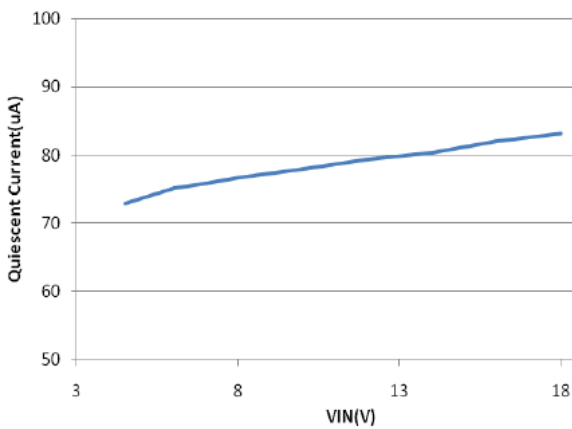

12. Feedback Voltage vs. Temp.

$V_{IN}=5V$, $V_{EN}=2.5V$, Sweep FB voltage @ different temperature

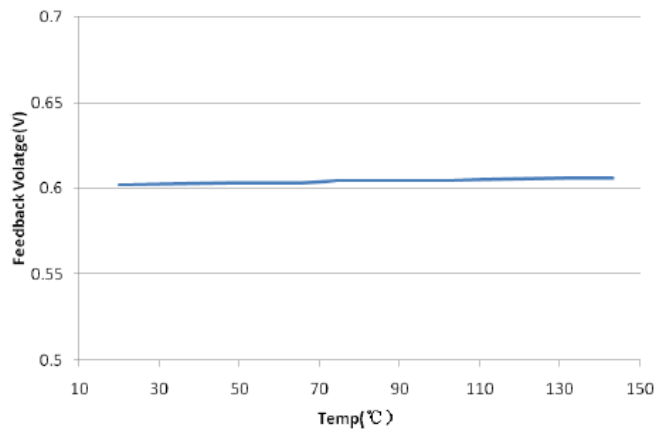



**13. Quiescent Current @ Temperature =25°C
Efficiency @ $V_{OUT}=5V$**

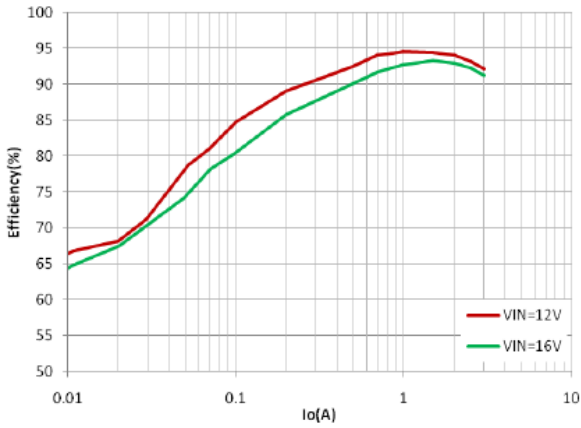

14. Efficiency @ $V_{OUT}=3.3V$

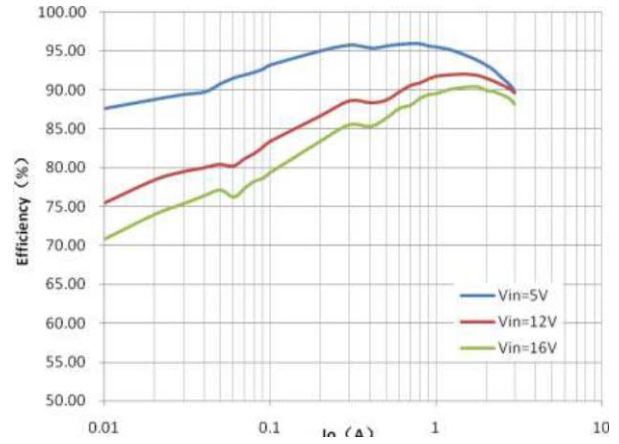

15. Load regulation @ $V_{OUT}=3.3V$

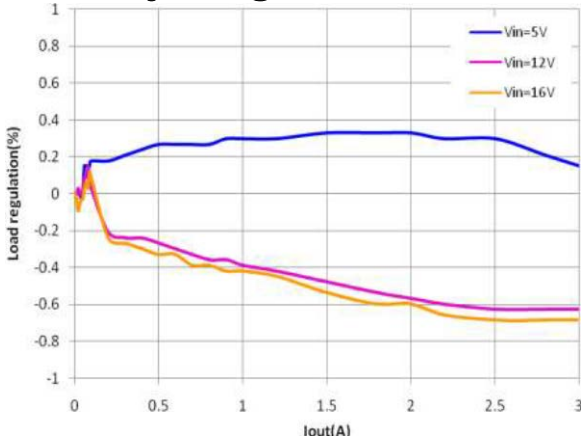



BLOCK DIAGRAM

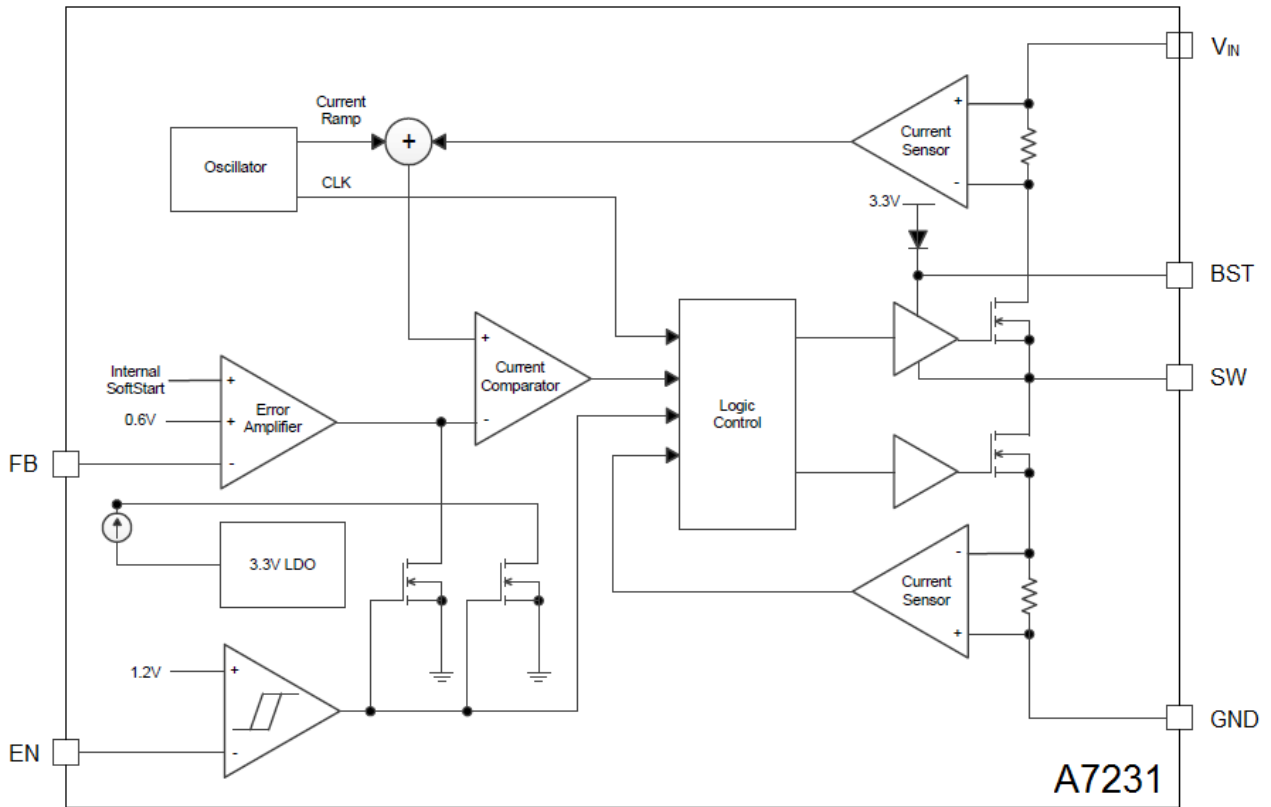



DETAILED INFORMATION

The A7231 is a synchronous, buck voltage converter.

Current-Mode Control

The A7231 utilizes current-mode control to regulate the FB voltage. Voltage at the FB pin is regulated at 0.6V so that by connecting an appropriate resistor divider between V_{OUT} and GND, designed output voltage can be achieved.

PFM Mode

The A7231 operates in PFM mode at light load. In PFM mode, switch frequency decreases when load current drops to boost power efficiency at light load by reducing switch-loss, while switch frequency increases when load current rises, minimizing output voltage ripples.

Internal Soft-start

Soft-Start makes output voltage rising smoothly follow an internal SS voltage until SS voltage is higher than the internal reference voltage. It can provide overshoot of output voltage when startup.

Power Switch

N-Channel MOSFET switches are integrated on the A7231 to down convert the input voltage to the regulated output voltage. Since the top MOSFET needs a gate voltage greater than the input voltage, a boost capacitor connected between BST and SW pins is required to drive the gate of the top switch. The boost capacitor is charged by the internal 3.3V rail when SW is low.

V_{IN} Under-Voltage Protection

A resistive divider can be connected between V_{IN} and ground, with the central tap connected to EN, so that when V_{IN} drops to the pre-set value, EN drops below 1.2V to trigger input under voltage lockout protection.

Output Current Run-Away Protection

At start-up, due to the high voltage at input and low voltage at output, current inertia of the output inductance can be easily built up, resulting in a large start-up output current. A valley current limit is designed in the A7231 so that only when output current drops below the valley current limit can the top power switch be turned on. By such control mechanism, the output current at start-up is well controlled.



Over Current Protection and Hiccup

A7231 has a cycle-by-cycle current limit. When the inductor current triggers current limit, A7231 enters hiccup mode and periodically restart the chip. A7231 will exit hiccup mode while not triggering current limit.

Thermal Protection

When the temperature of the A7231 rises above 145°C, it is forced into thermal shut-down. Only when core temperature drops below 125°C can the regulator becomes active again.

Application Information

Output Voltage Set

The output voltage is determined by the resistor divider connected at the FB pin, and the voltage ratio is:

$$V_{FB} = V_{OUT} \times \frac{R_2}{R_2 + R_1}$$

where V_{FB} is the feedback voltage and V_{OUT} is the output voltage.

Choose R_2 around 10kΩ~15kΩ, and then R_1 can be calculated by:

$$R_1 = \left(\frac{V_{OUT}}{0.6} - 1 \right) \times R_2$$

The following table lists the recommended values.

$V_{OUT}(V)$	$R_1(k\Omega)$	$R_2(k\Omega)$
2.5	47	15
3.3	49.5	11
5	110	15

Input Capacitor

The input capacitor is used to supply the AC input current to the step-down converter and maintaining the DC input voltage. The ripple current through the input capacitor can be calculated by:

$$I_{C1} = I_{LOAD} \times \sqrt{\frac{V_{OUT}}{V_{IN}} \times \left(1 - \frac{V_{OUT}}{V_{IN}} \right)}$$

where I_{LOAD} is the load current, V_{OUT} is the output voltage, V_{IN} is the input voltage.

Thus the input capacitor can be calculated by the following equation when the input ripple voltage is determined.

$$C_1 = \frac{I_{LOAD}}{f_s \times \Delta V_{IN}} \times \frac{V_{OUT}}{V_{IN}} \times \left(1 - \frac{V_{OUT}}{V_{IN}} \right)$$

typically allowed to be 30% of the maximum



where C_1 is the input capacitance value, f_s is the switching frequency, ΔV_{IN} is the input ripple voltage.

The input capacitor can be electrolytic, tantalum or ceramic. To minimizing the potential noise, a small X5R or X7R ceramic capacitor, i.e. 0.1uF, should be placed as close to the IC as possible when using electrolytic capacitors.

A 22uF ceramic capacitor is recommended in typical application.

Output Capacitor

The output capacitor is required to maintain the DC output voltage, and the capacitance value determines the output ripple voltage. The output voltage ripple can be calculated by:

$$\Delta V_{OUT} = \frac{V_{OUT}}{f_s \times L} \times \left(1 - \frac{V_{OUT}}{V_{IN}}\right) \times \left(R_{ESR} + \frac{1}{8 \times f_s \times C_2}\right)$$

where C_2 is the output capacitance value and R_{ESR} is the equivalent series resistance value of the output capacitor.

The output capacitor can be low ESR electrolytic, tantalum or ceramic, which lower ESR capacitors get lower output ripple voltage.

The output capacitors also affect the system stability and transient response, and a 47uF ceramic capacitor is recommended in typical application.

Inductor

The inductor is used to supply constant current to the output load, and the value determines the ripple current which affect the efficiency and the output voltage ripple. The ripple current is switch current limit, thus the inductance value can be calculated by:

$$L = \frac{V_{OUT}}{f_s \times \Delta I_L} \times \left(1 - \frac{V_{OUT}}{V_{IN}}\right)$$

where V_{IN} is the input voltage, V_{OUT} is the output voltage, f_s is the switching frequency, and ΔI_L is the peak-to-peak inductor ripple current.

External Bootstrap Capacitor

A bootstrap capacitor is required to supply voltage to the top switch driver. A 0.1uF low ESR ceramic capacitor is recommended to connected to the BST pin and SW pin.

Load Transient Improvement

To improve the load transient performance, a feed forward capacitor (C_{ff}) can be added in parallel with the feedback resistor (R_1). (Figure1.). At the same time, to avoid the voltage offset which is caused by substrate



injection, a 20k resistor (R0) is recommended to insert between the FB PIN and resistance divider.

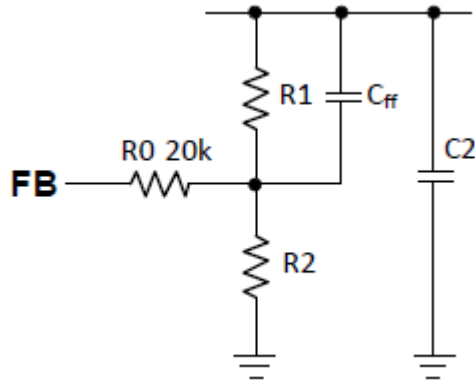

Figure 1

PCB Layout Note

For minimum noise problem and best operating performance, the PCB is preferred to following the guidelines as reference.

1. Place the input decoupling capacitor as close to A7231 (V_{IN} pin and PGND) as possible to eliminate noise at the input pin. The loop area formed by input capacitor and GND must be minimized.
2. Put the feedback trace as far away from the inductor and noisy power traces as possible.
3. The ground plane on the PCB should be as large as possible for better heat dissipation.



REFERENCE DESIGN

Reference 1:

V_{IN} : 4.5V ~ 18 V

V_{OUT} : 3.3V

I_{OUT} : 0~3A

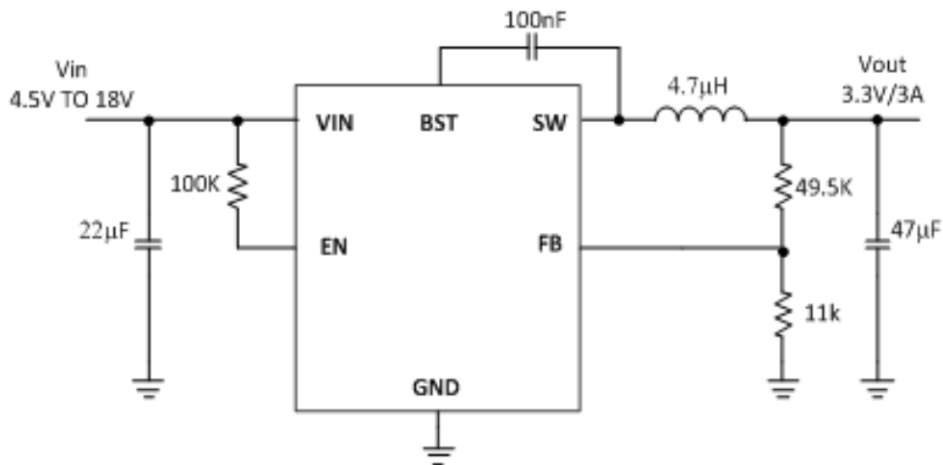

Reference 2:

V_{IN} : 6.5V ~ 18 V

V_{OUT} : 5V

I_{OUT} : 0~3A

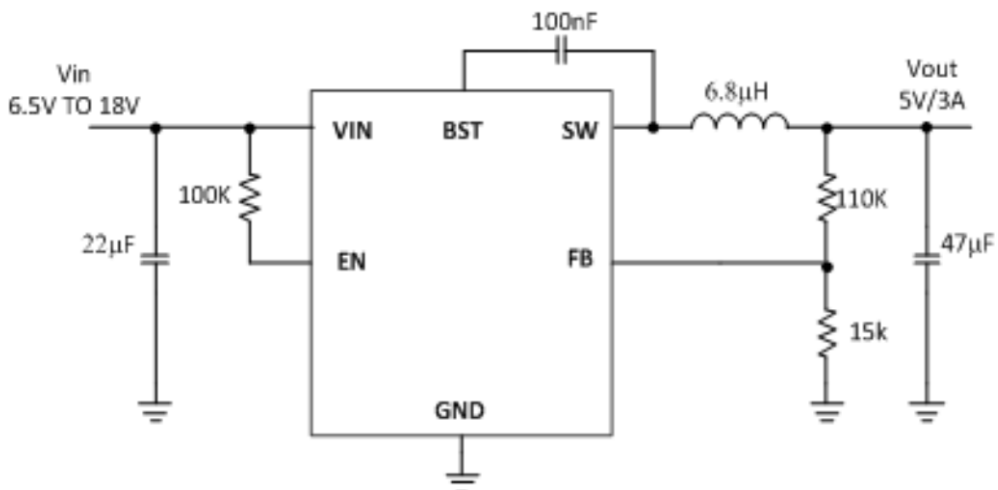



PACKAGE INFORMATION

Dimension in TSOT-26 (Unit: mm)

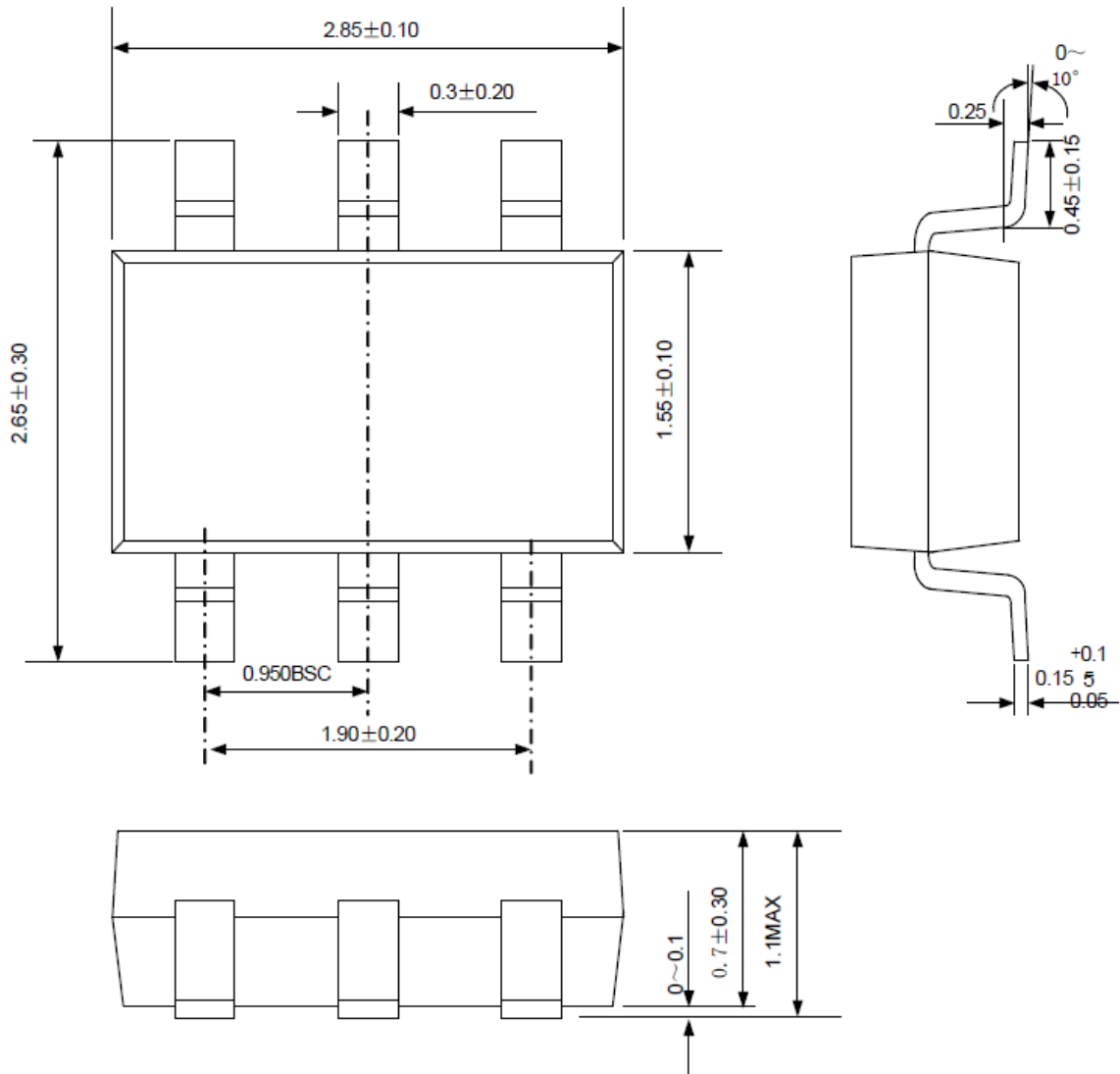



IMPORTANT NOTICE

AiT Semiconductor Inc. (AiT) reserves the right to make changes to any its product, specifications, to discontinue any integrated circuit product or service without notice, and advises its customers to obtain the latest version of relevant information to verify, before placing orders, that the information being relied on is current.

AiT Semiconductor Inc.'s integrated circuit products are not designed, intended, authorized, or warranted to be suitable for use in life support applications, devices or systems or other critical applications. Use of AiT products in such applications is understood to be fully at the risk of the customer. As used herein may involve potential risks of death, personal injury, or severe property, or environmental damage. In order to minimize risks associated with the customer's applications, the customer should provide adequate design and operating safeguards.

AiT Semiconductor Inc. assumes to no liability to customer product design or application support. AiT warrants the performance of its products of the specifications applicable at the time of sale.

www.s-manuals.com