

General Description

The ADT7110 is a fixed frequency step-down converter designed to drive Infrared LEDs in the CCD camera module application.

And internal current limit circuit protect external devices.

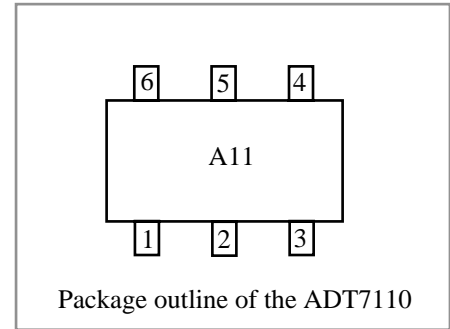

Features

- Input voltage range : 10.5V to 15V
- Current mode PWM controller with integrated compensation components
- 350mA output load current available
- Built-in chip enable/disable function
- Built-in current limit protection
- 500kHz fixed frequency internal oscillator
- Small outline SOT-26 package (2.9mm x 1.6mm body)

Applications

- Infrared LED driver for CCD camera

Typical Application Circuit

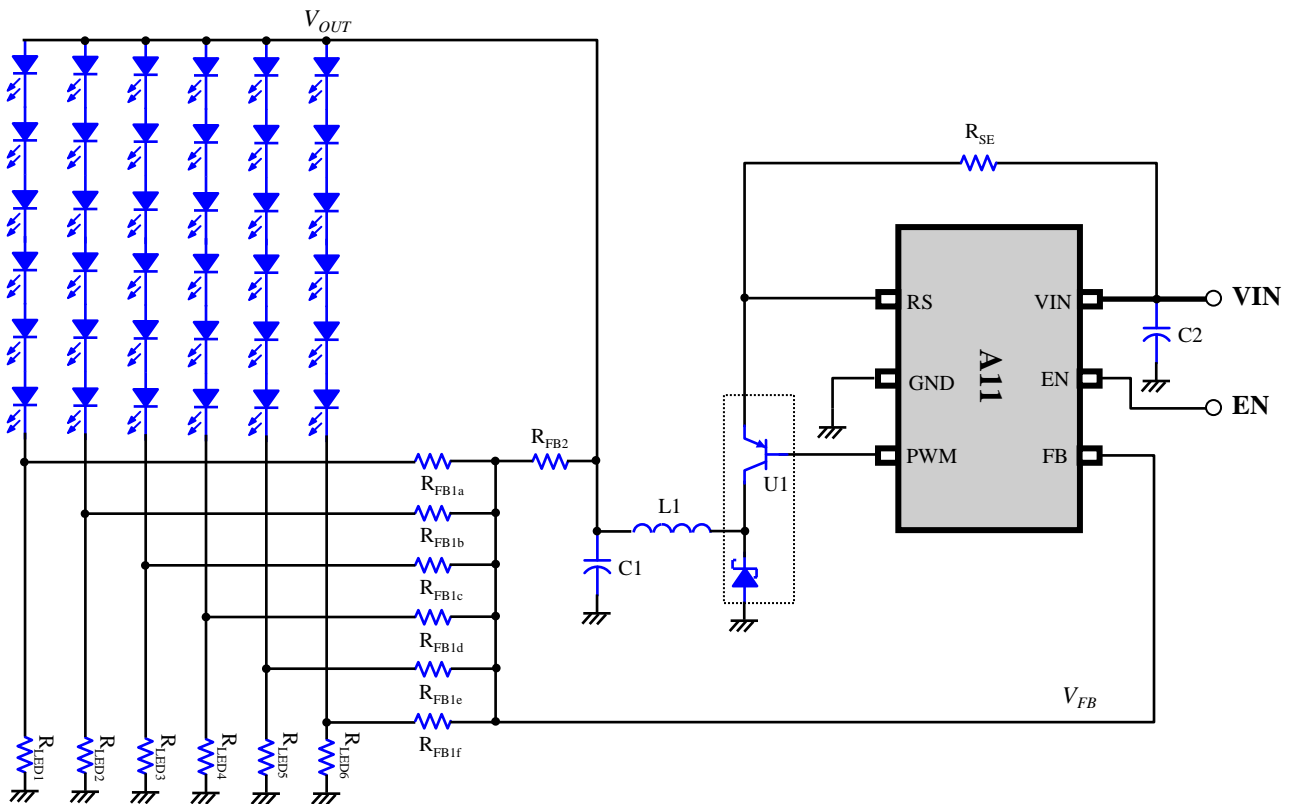

* This specifications are subject to be changed without notice

Part List

Component	Description	Type	Value
U1*1	Composite type with a PNP transistor and schottky barrier diode	IC	FP103
L1	Output filter inductor	Chip inductor	47uH/590mA
C1	Output filter capacitor	Tantalum capacitor	47uF/16V
C2	Bypass capacitor	Tantalum capacitor	10uF/25V
R _{SE}	Current sense resistor	Chip resistor	0.1Ω
R _{LED1} ~ R _{LED6} *2	LED current ballast resistor	Chip resistor , 1%	4.0Ω
R _{FB1a} ~ R _{FB1f}	Buck converter feedback loop component	Chip resistor	120kΩ (table 3)
R _{FB2} *3	Buck converter feedback loop component	Chip resistor , 1%	68kΩ (table 2)

*1 : For cost down , it is possible to use discrete component with a PNP transistor and a schottky barrier diode. In this case, you make use the discrete components with proper electrical specification. [Table A](#) shows the required key electrical limits. It is recommended to use PNP and schottky barrier diode having equivalent specification in the [Table A](#).

*2, *3 : To setting appropriate LED current, Refer to 'Application Hints'.

[Table A](#) : Selection guide for the discrete components

Component	Parameter	Ratings	Unit	Remarks
PNP	Collector to Emitter Voltage	-23	V	Recommend '2SB1706' by ROHM or Equivalent IC
	Collector Current	-2	A	
Schottky Barrier Diode	Repetitive Peak Reverse Voltage	30	V	Recommend 'RSX101M-30' by ROHM or Equivalent
	Average Rectified Current	700	mA	

Package ; SOT-26, 2.9mm x 1.6mm body (units : mm)

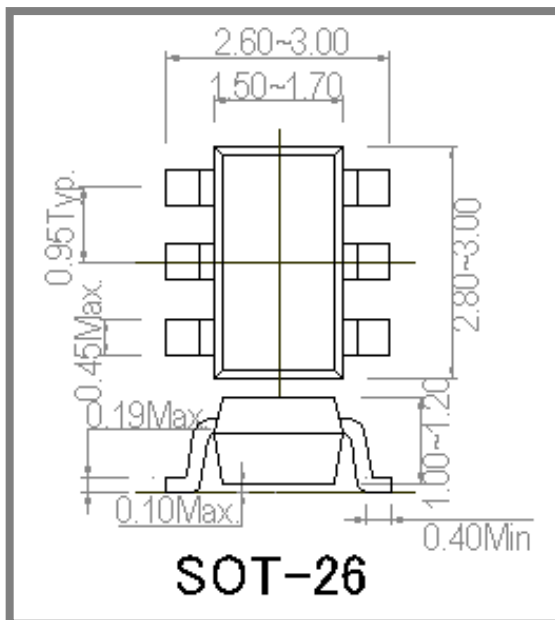

* This specifications are subject to be changed without notice

Pin Configuration

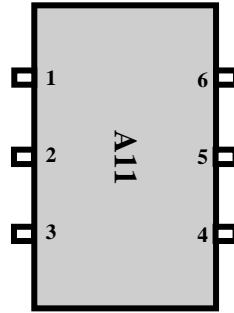

Pin Description

Pin No.	Name	I/O	Type	Description
1	RS	I	A	Current sense and provide voltage feed-forward.
2	GND	-	G	Ground
3	PWM	O	D	Switching output.
4	FB	I	A	Feedback voltage input
5	EN	I	D	Device enable pin
6	VIN	-	P	Power supply input

I : Input pin O : Output pin IO : Input/Output pin
 P : Power pin G : Ground pin
 A : Analog pin D : Digital pin

Functional Block Diagram

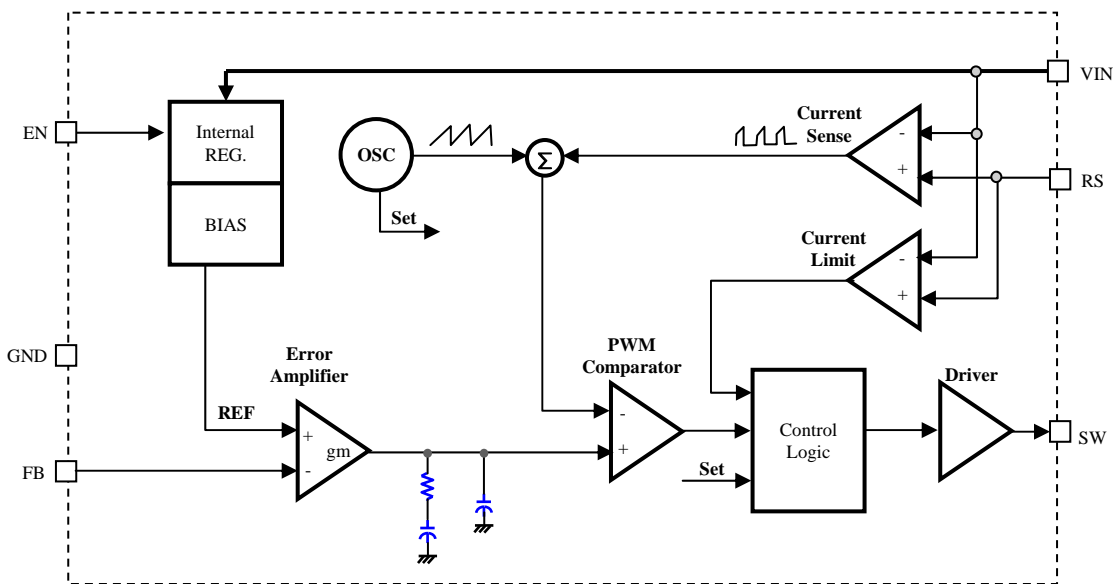

* This specifications are subject to be changed without notice

Absolute Maximum Ratings

Parameter	Symbol	Min.	Typ.	Max.	Unit
Power supply voltage	V_{IN}	-	-	23	V
Power dissipation ($T_a=70^\circ\text{C}$) (Note1)	P_{Dmax}	-	-	265	mW
Storage temperature	T_{STG}	-65	-	+150	$^\circ\text{C}$
Junction temperature	T_{Jmax}	-	-	+150	$^\circ\text{C}$
Thermal resistance	Θ_{JA}	-	301.2	-	$^\circ\text{C}/\text{W}$

Note1. derate 301 $^\circ\text{C}/\text{W}$ above $+70^\circ\text{C}$.

Stresses beyond those listed under “Absolute Maximum Ratings” may cause permanent damage to the device. These are stress ratings only, and functional operation of the device at these or any other conditions beyond those indicated in the operational sections of the specifications is not implied. Exposure to absolute maximum rating conditions for extended periods may affect device reliability.

Operating Ratings

Parameter	Symbol	Min.	Typ.	Max.	Unit
Power supply voltage*2	V_{IN}	10.5	12.0	15.0	V
Operating temperature	T_{OPR}	-20	-	+85	$^\circ\text{C}$
Junction temperature	T_J	-	-	+125	$^\circ\text{C}$
Max. power dissipation ($T_a=70^\circ\text{C}$)*1	P_D	-	-	180	mW

*1 This spec. indicates that junction temperature of the device is under 125°C . In specific applications, this is recommended under this power dissipation specification.

*2 Minimum V_{IN} operating range is dependant to the V_{OUT} voltage. ($V_{IN\ min.} \doteq V_{OUT} + 0.5\text{V}$)
Maximum V_{IN} operating range can be extended. In this case, maximum drive current is limited.

For using V_{IN} over 15V, refer to the [Table B](#).

Table B : Maximum drive current as maximum V_{IN} operating voltage.

V_{IN} (V)	16	17	18	19	20	21	22
Drive current (mA)	330	310	290	270	250	230	210

Electrical Characteristics ($T_a=25^\circ\text{C}$, $V_{IN}=12\text{V}$, unless otherwise noted)

Parameter	Condition	MIN	TYP	MAX	Unit	Note
Supply current, operating	$V(\text{EN}) = 3.3\text{V}$, $I_O=300\text{mA}$	-	6	9	mA	
Supply current, disable	$V(\text{EN}) = 0\text{V}$	-	90	200	μA	
$V(\text{EN})$, input voltage high	-	2.4	-	-	V	
$V(\text{EN})$, input voltage low	-	-	-	1.2	V	
PWM controller						
Output drive current	$V_{IN} \leq 15\text{V}$	-	300	350	mA	
Current limit	-	550	-	-	mA	
Efficiency	$I_O=300\text{mA}$	-	85	-	%	
Oscillator frequency	$I_O=300\text{mA}$	350	500	625	kHz	
Feedback voltage (V_{FB})	$I_O=300\text{mA}$	2.16	2.21	2.26	V	

www.s-manuals.com