



General Description

The AF1937K is a step-up DC/DC converter specifically designed to drive white LEDs with a constant current. The device can drive up to 27 LEDs from a 5V supply. Additional features include output voltage limiting when LEDs are disconnected.

Features

- ◆ Inherently Matched LED Current
- ◆ Drives Up to 27 LEDs from a 5V Supply
- ◆ 36V Rugged Bipolar Switch
- ◆ Fast 1.2MHz Switching Frequency
- ◆ $V_{OUT(MAX)}=30V$

Application

- Battery Power Equipment
- Notebook Computers
- PDA
- Cellular Phone
- Digital Cameras
- MP3 Players
- GPS Receivers

Pin Define

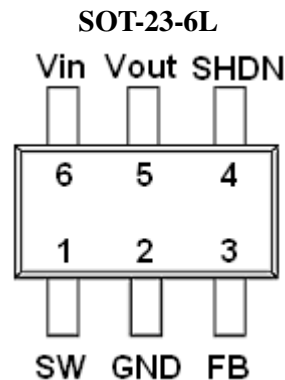

Marking Information

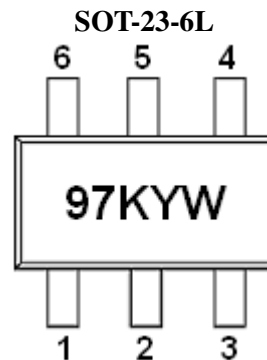



Block Diagram

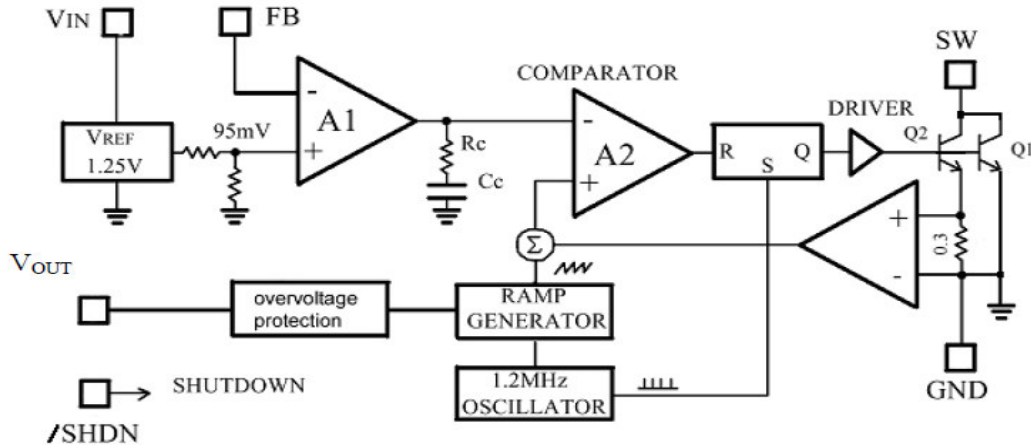

Typical Application Circuit

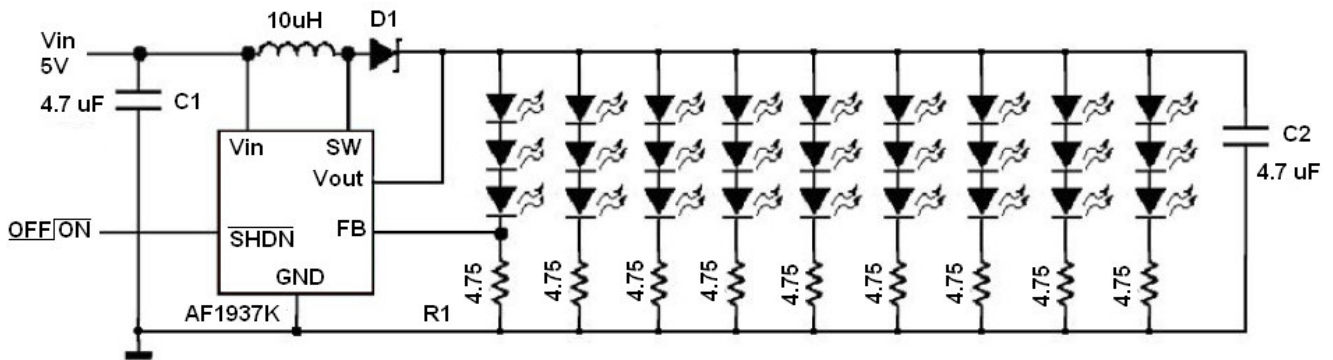

Pin Description (SOT-23-6L)

Pin	Symbol	Description
1	SW	Switch Pin.
2	GND	Ground Pin
3	FB	Feedback Pin.
4	SHDN	Shutdown Pin. Active-low enable
5	Vout	Voltage Output
6	Vin	Supply Voltage Input

Ordering Information

Part Number	Package	Part Marking	Unit	Quantity
AF1937KS26RG	SOT-23-6L	97KYW	Tape & Reel	3000 EA

- ※ Y : Year Code
- ※ W : Week Code : A ~ Z (1 ~ 26) ; a ~ z (27 ~ 52)
- ※ AF1937KS26RG : Tape Reel ; 7" Pb- Free ; Halogen- Free



Absolute Maximum Ratings

(T_A=25°C Unless otherwise noted)

Parameter	Symbol	Value	Unit
DC Supply Voltage	V _{in}	20	V
SW Voltage	V _{SW}	36	V
FB Voltage	V _{FB}	10	V
SHDN Voltage	V _{SHDN}	10	V
Operating Temperature	T _{OPR}	0~70	°C
Maximum Junction Temperature	T _{J(Max)}	125	°C
Storage Temperature	T _S	-65~150	°C

Note : Absolute Maximum Ratings are those values beyond which the life of the device may be impaired.

Electrical Characteristics

(T_A=25°C, V_{in} = 5V, V_{/SHDN} = 5V, unless otherwise noted. Unless otherwise noted)

PARAMETER	CONDITIONS	MIN.	TYP.	MAX.	UNIT
Minimum Operating Voltage		2.5			V
Maximum Operating Voltage				10	V
Feedback Voltage	I _{LOAD} = 180mA, V _{IN} =5V	83	95	107	mV
	I _{LOAD} = 100mA, V _{IN} =5V	86	95	104	
FB Pin Bias Current		10	45	100	nA
Supply Current	/SHDN = 0V		2.1	3.0	mA
			0.1	1.0	
Switching Frequency		1.1	1.3	1.6	MHz
Maximum Duty Cycle		85	90		%
Switch Current Limit			650		mA
Switch V _{CESAT}	I _{SW} = 250mA		350		mV
Switch Leakage Current	V _{SW} = 5V		0.01	5	μA
/SHDN Voltage High		1.5			V
/SHDN Voltage Low				0.4	V
/SHDN Pin Bias Current			65		μA
OVP Threshold			29		V



Application Note

OPERATION

The AF1937K uses a constant frequency, current mode control scheme to provide excellent line and load regulation. Operation can be best understood by referring to the block diagram. At the start of each oscillator cycle, the RS latch is set, which turns on the power switch Q1. A voltage proportional to the switch current is added to a stabilizing ramp and the resulting sum is fed into the positive terminal of the PWM comparator A2. When this voltage exceeds the level at the negative input of A2, the RS latch is reset turning off the power switch. The level at the negative input of A2 is set by the error amplifier A1, and is simply an amplified version of the difference between the feedback voltage and the reference voltage of 95mV. In this manner, the error amplifier sets the correct peak current level to keep the output in regulation. If the error amplifier's output increases, more current is delivered to the output; if it decreases, less current is delivered.

Inductor Selection

A 10 μ H inductor is recommended for most AF1937K applications. Although small size and high efficiency are major concerns, the inductor should have low core losses at 1.2MHz and low DCR (copper wire resistance).

Capacitor Selection

The small size of ceramic capacitors makes them ideal for AF1937K applications. X5R and X7R types are recommended because they retain their capacitance over wider voltage and temperature ranges than their types such as Y5V or Z5U. A 4,7 μ F input capacitor and a 4,7Mf output capacitor are sufficient for most AF1937K application.

Diode Selection

Schottky diodes, with their low forward voltage drop and fast reverse recovery, are the ideal choices for AF1937K applications. The forward voltage drop of a Schottky diode represents the conduction losses in the diode, while the diode capacitance (CT or CD) represents the switching losses. For diode selection, both forward voltage drop and diode capacitance need to be considered. Schottky diodes with higher current ratings usually have lower forward voltage drop and larger diode capacitance, which can cause significant switching losses at the 1.2MHz switching frequency of the AF1937K. A Schottky diode rated at 1000mA is sufficient for most AF1937K application.



Package Information (SOT-23-6L)

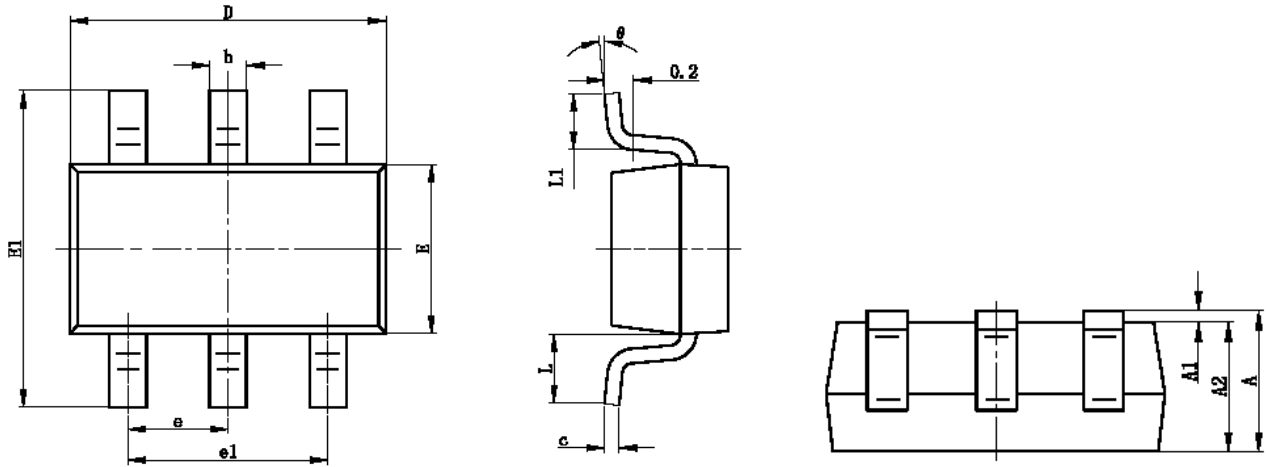

Symbol	Dimensions In Millimeters		Dimensions In Inches	
	Min	Max	Min	Max
A	1.050	1.250	0.041	0.049
A1	0.000	0.100	0.000	0.004
A2	1.050	1.150	0.041	0.045
b	0.300	0.400	0.012	0.016
c	0.100	0.200	0.004	0.008
D	2.820	3.020	0.111	0.119
E	1.500	1.700	0.059	0.067
E1	2.650	2.950	0.104	0.116
e	0.950TYP		0.037TYP	
e1	1.800	2.000	0.071	0.079
L	0.700REF		0.028REF	
L1	0.300	0.600	0.012	0.024
θ	0°	8°	0°	8°

©2010 Alfa-MOS Technology Corp.
 2F, No.80, Sec.1, Cheng Kung Rd., Nan Kang Dist., Taipei City 115, Taiwan (R.O.C.)
 Tel : 886 2) 2651 3928
 Fax : 886 2) 2786 8483
 ©http://www.alfa-mos.com

www.s-manuals.com