

Description

The AP5725 is a step-up DC/DC converter specifically designed to drive white LEDs with a constant current. The device can drive 2 ~ 6 LEDs in series from a Li-Ion cell. Series connection of the LEDs provides identical LED currents resulting in uniform brightness and eliminates the need for ballast resistors. For driving higher number of LEDs, AP5725 also supports a single feedback of parallel connected multiple strings of equal number of LEDs.

The AP5725 switches at 1.2MHz that allows the use of tiny external components. A low 0.25V feedback voltage minimizes power loss in the current setting resistor for better efficiency.

Features

- High efficiency: 84% typical
- Fast 1.2MHz switching frequency
- Current limit and UVLO protections
- Internal thermal shutdown
- Internal Over Voltage Protection
- Integrated soft-start function
- SOT26, TSOT23-6 and DFN2020C-6: Available in "Green" Molding Compound (No Br, Sb)
- Lead Free Finish/ RoHS Compliant (Note 1)

Notes: 1. EU Directive 2002/95/EC (RoHS). All applicable RoHS exemptions applied. Please visit our website at http://www.diodes.com/products/lead_free.html.

Pin Assignments



Applications

- Cellular Phones
- PDAs, Hand held Computers
- Digital Cameras
- MP3 Players
- GPS Receivers

Typical Application Circuit

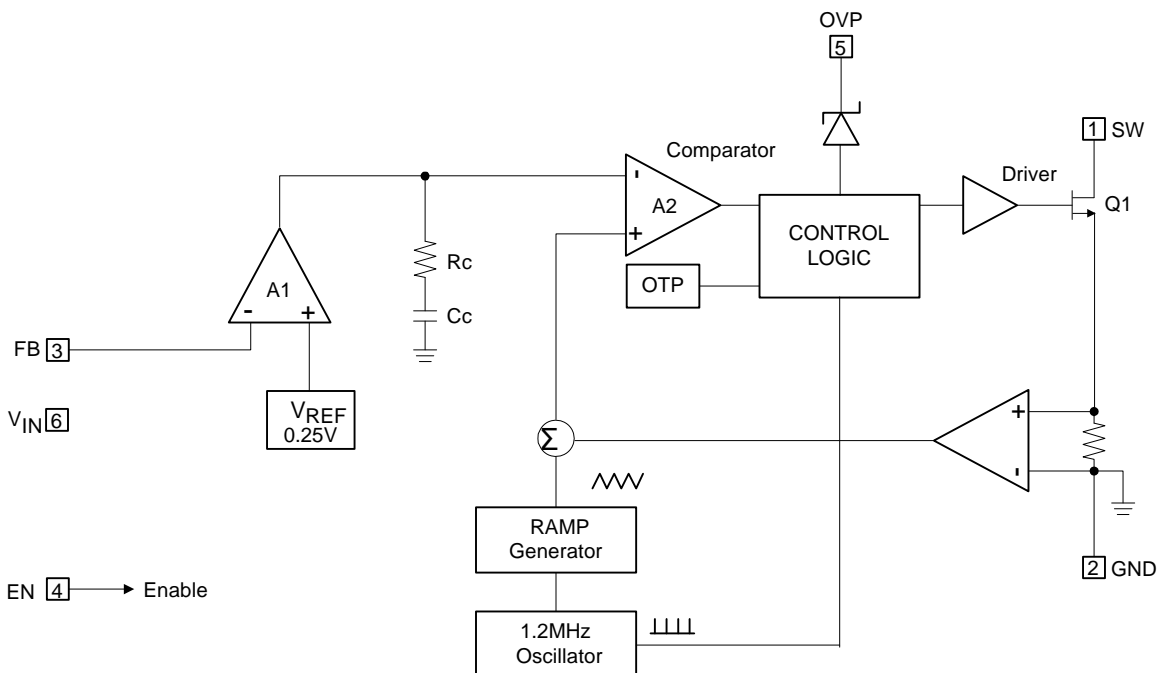

Figure 1. Typical Application Circuit

Pin Descriptions

Pin Name	Description
SW	Switch Pin. Connect inductor/diode here. Minimize trace area at this pin to reduce EMI.
GND	GND pin.
FB	Feedback Pin. Reference voltage is 0.25V. Connect cathode of lowest LED and a sense resistor here. Calculate resistor value according to the formula: $R_{SET} = 0.25V / I_{LED}$
EN	Converter On/Off Control Input. A high input at EN turns the converter On, and a low input turns it off. If On/Off control is not needed, connect EN to the input source for automatic startup. The EN pin cannot be left floating.
OVP	Output Voltage detect pin for over voltage protection.
V _{IN}	Input Supply Pin. Must be locally bypassed with 1μF or 2.2μF to reduce input noise.

Functional Block Diagram



Absolute Maximum Ratings

Symbol	Parameter	Rating	Unit
V_{IN}	VIN Pin Voltage	-0.3~7	V
VSW	SW Voltage	-0.3~34	V
V_{OVP}	OVP Pin Voltage	-0.3~35	V
V_{FB}	Feedback Pin Voltage	-0.3~7	V
EN	EN	-0.3~7	V
$T_{J(MAX)}$	Maximum Junction Temperature	150	°C
T_{LEAD}	Lead Temperature	300	°C
T_{ST}	Storage Temperature Range	-65 to +150	°C

Caution: Operation above the absolute maximum ratings can cause device failure. These values, therefore, must not be exceeded under any condition. Operation at the absolute maximum rating for extended periods, may reduce device reliability.

Recommended Operating Conditions

Symbol	Parameter	Min	Max	Unit
V_{IN}	Input Voltage	2.7	5.5	V
T_J	Operating Junction Temperature	-40	125	°C
T_A	Operating Ambient Temperature	-40	85	°C

Electrical Characteristics ($V_{IN} = 3.6V$, $T_A = 25^\circ C$, unless otherwise specified.)

Symbol	Parameter	Conditions	Min	Typ.	Max	Unit
System Supply Input						
V_{IN}	Operating Input Voltage		2.7	-	5.5	V
UVLO	Under Voltage Lockout		-	2.2	2.4	V
	Under Voltage Lockout Hysteretic		-	85	-	mV
I_Q	Quiescent Current	FB=0.35V, No Switching	-	500	-	μA
I_{SD}	Shutdown Current	$V_{EN} < 0.4V$	-	0.1	1	μA
Oscillator						
F_{OSC}	Operation Frequency		1	1.2	1.4	MHz
Dmax	Maximum Duty Cycle		86	90	-	%
Reference Voltage						
V_{FB}	Feedback Voltage		0.225	0.25	0.275	V
I_{FB}	FB Pin Bias Current		10	45	100	nA
MOSFET						
Rds(on)	On Resistance of MOSFET		-	0.95	1.2	Ω
I_{OCP}	Switching Current Limit	Normal Operation	-	750	-	mA
Control and Protection						
EN	Voltage High	ON	1.5	-	-	V
EN	Voltage Low	OFF	-	-	0.4	V
I_{EN}	EN Pin Pull Low Current		-	4	6	μA
OVP	OVP Threshold		26	30	34	V
θ_{JA}	Thermal Resistance Junction-to-Ambient	SOT26 (Note 2)		162		$^\circ C/W$
		TSOT23-6 (Note 2)		152		
		DFN2020C-6 (Note2)		200		
θ_{JC}	Thermal Resistance Junction-to-Case	SOT26 (Note 2)		36		$^\circ C/W$
		TSOT23-6 (Note 2)		32		
		DFN2020C-6 (Note 2)		30		

Notes: 2. Test condition for SOT26, TSOT23-6 and DFN2020C-6: Device mounted on FR-4 substrate, single-layer PC board, 2oz copper, with minimum recommended pad layout

Typical Performance Characteristics (6 LEDs ; $V_{IN} = 3.6V$; $I_{OUT} = 25mA$)

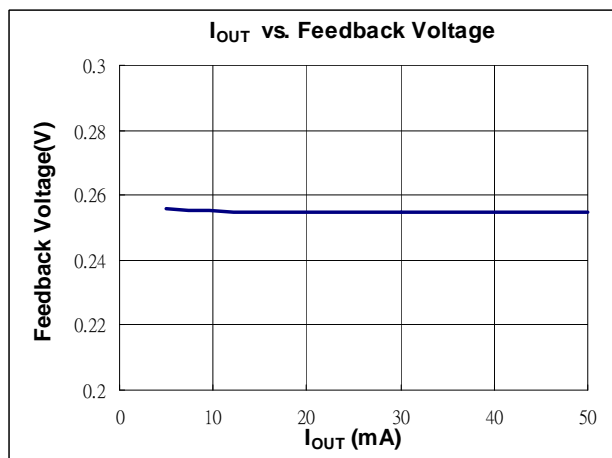
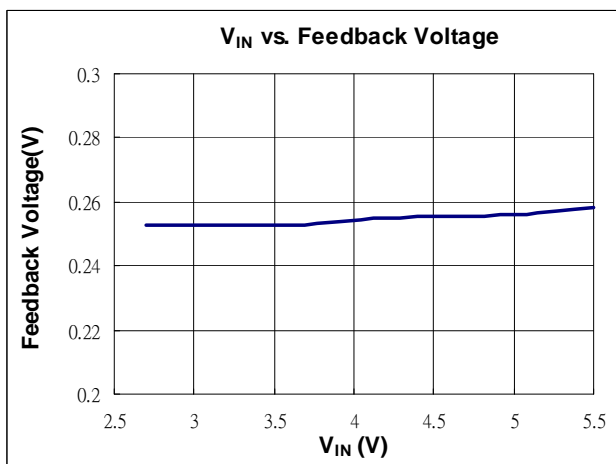
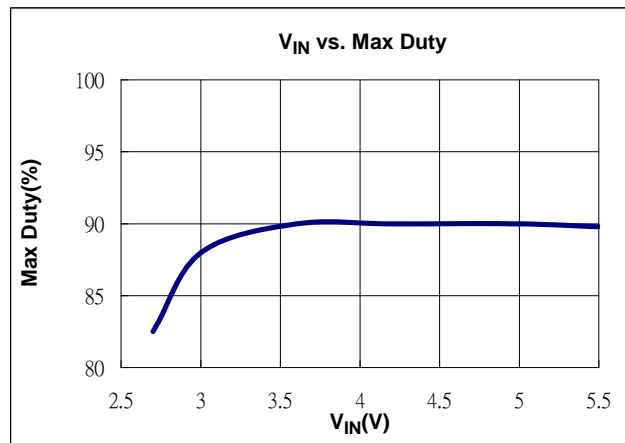
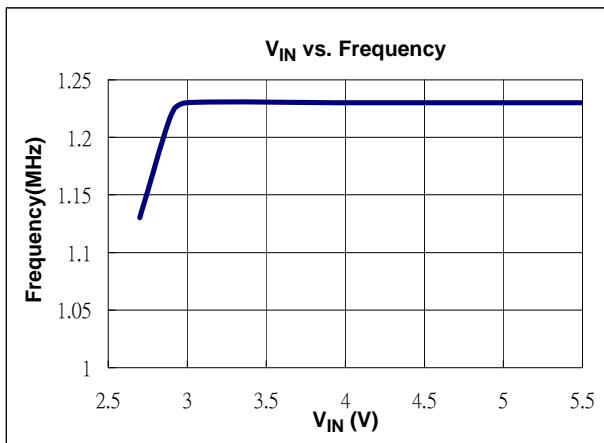

Typical Performance Characteristics (Continued)

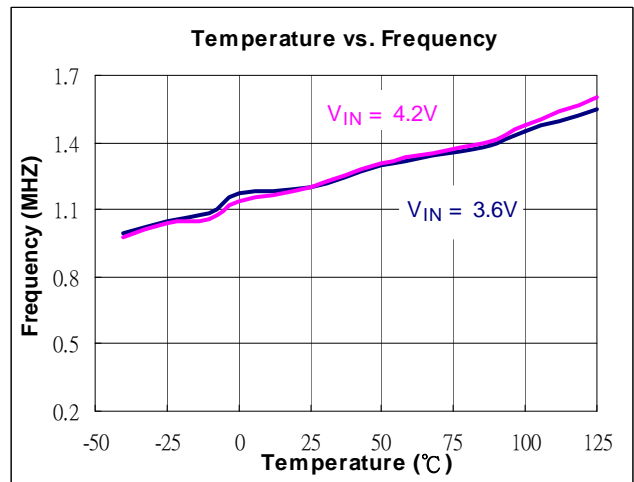

Typical Performance Characteristics (Continued)

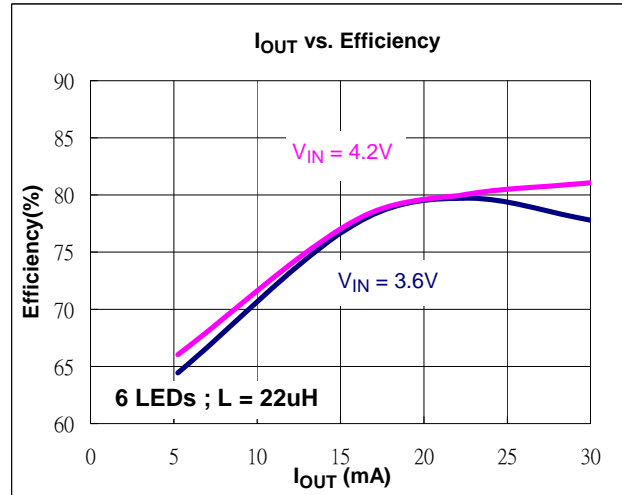

Typical Performance Characteristics (Continued)

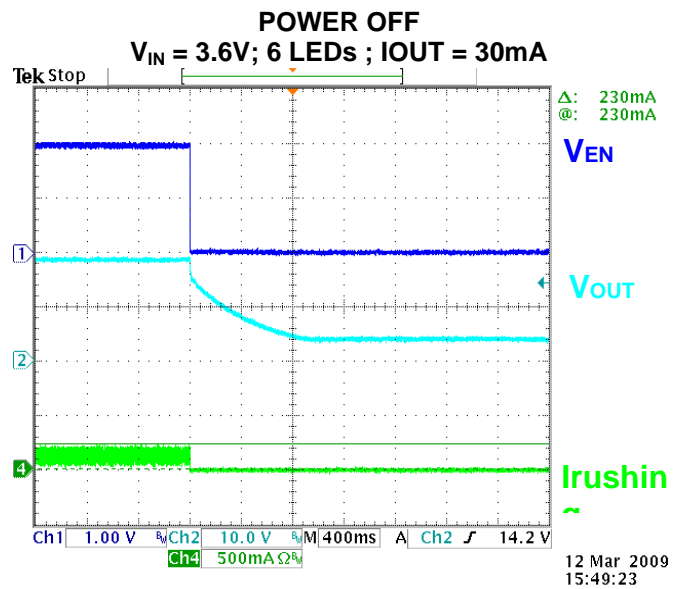
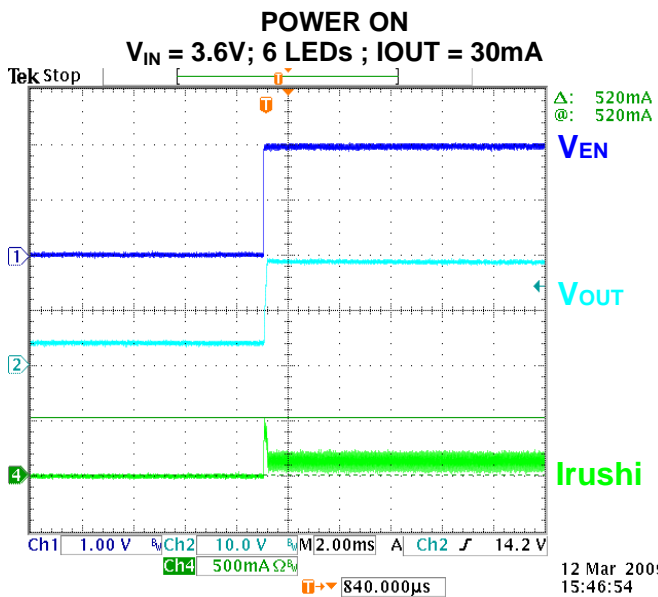
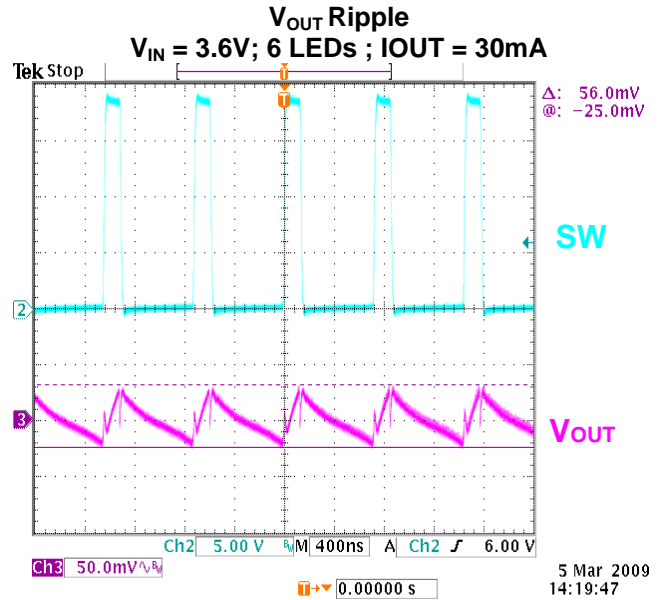
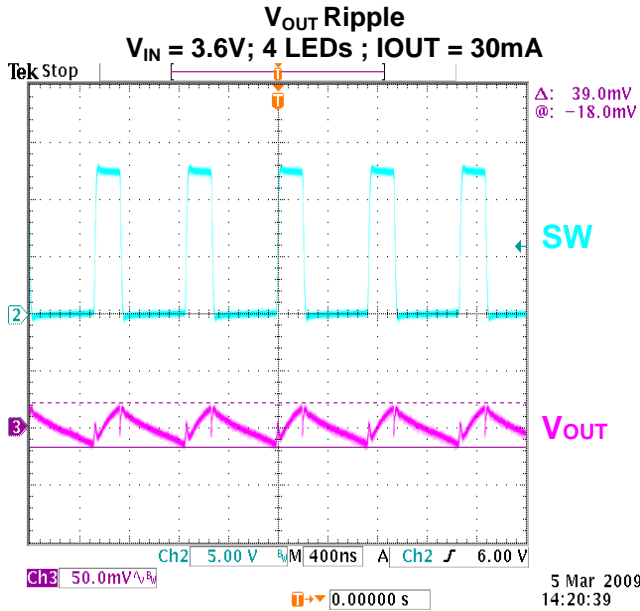

Applications Information

Inductor Selection

A 10 μ H–22 μ H inductor is recommended for most AP5725 applications. For high efficiency the inductor should have low core losses at 1.2MHz and low DCR (copper wire resistance). The inductor saturation current rating should also exceed the peak input current, especially for high load current applications (like 3S8P).

Capacitor Selection

The small size of ceramic capacitors are ideal for AP5725 applications. X5R and X7R types are recommended because they retain their capacitance over wider voltage and temperature ranges than other types such as Y5V or Z5U. A 1 μ F input capacitor and a 1 μ F output capacitor are sufficient for most AP5725 applications. For high output current applications like 3S8P, larger output capacitor of 2.2 μ F ~ 4.7 μ F is recommended to minimize output ripple.

Diode Selection

Schottky diodes, with their low forward voltage drop and fast reverse recovery, are the ideal choices for AP5725 applications. The forward voltage drop of a Schottky diode represents the conduction losses in the diode, while the diode capacitance (C_T or C_D) represents the switching losses. For diode selection, both forward voltage drop and diode capacitance need to be considered. Schottky diodes with higher current ratings usually have lower forward voltage drop and larger diode capacitance, which can cause significant switching losses at the 1.2MHz switching frequency of the AP5725. Schottky diodes with higher current ratings usually have lower forward voltage drop and larger diode capacitance. Larger Schottky diode capacitance can cause significant switching losses at the 1.2MHz switching frequency of the AP5725. A Schottky diode rated at 100mA to 200mA is sufficient for most AP5725 applications.

LED Current Control

The LED current is controlled by the feedback resistor (R_{SET} in **Figure 1**). The feedback reference is 0.25V. The LED current is $0.25V / R_{SET}$. In order to have accurate LED current, precision resistors are preferred (1% is recommended). The formula and table for R_{SET} selection are shown below.

$$R_{SET} = 0.25V / I_{LED} \text{ (See Table 1)}$$

Table 1. R_{SET} Resistor Value Selection

I_{LED} (mA)	R_{SET} (Ω)
5	50
10	25
15	16.6
20	12.5
30	8.3

Applications Information (Continued)

Open-Circuit Protection

In the cases of output open circuit, when the LEDs are disconnected from the circuit or the LEDs fail, the feedback voltage will be zero. The AP5725 will then switch at a high duty cycle resulting in a high output voltage, which may cause the SW and OVP pin voltage to exceed the voltage rating of these pins. The OVP pin monitors the output voltage. If the output voltage reaches the over voltage protection threshold at the OVP pin (**Figure 2**), the over voltage protection is activated and SW pin stops switching.

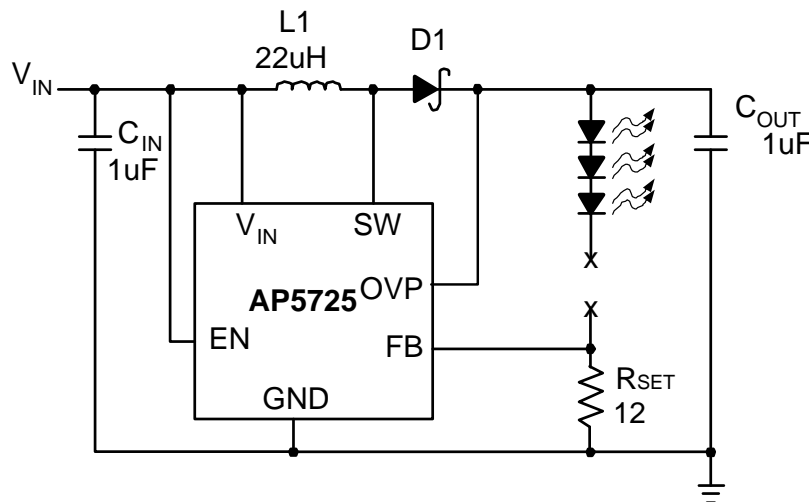

Figure 2. LED Driver with Open-Circuit Protection

Dimming Control

There are four different types of dimming control circuits:

1. Using a PWM Signal to EN Pin

With the PWM signal applied to the EN pin, the AP5725 is turned on or off by the PWM signal. The LEDs operate at either zero or full current. The average LED current increases proportionally with the duty cycle of the PWM signal. A 0% duty cycle will turn off the AP5725 and corresponds to zero LED current. A 100% duty cycle corresponds to full current. The typical frequency range of the PWM signal is below 2kHz.

Applications Information (Continued)

2. Using a DC Voltage

For some applications, the preferred method of brightness control is a variable DC voltage to adjust the LED current. The dimming control using a DC voltage is shown in **Figure 3**. As the DC voltage increases, the voltage drop on R2 increases and the voltage drop on R_{SET} decreases. Thus, the LED current decreases. The selection of R2 and R3 will make the current from the variable DC source much smaller than the LED current and much larger than the FB pin bias current. For V_{DC} range from 0V to 2V, the selection of resistors in **Figure 3** gives dimming control of LED current from 0mA to 20mA.



Figure 3. Dimming Control Using a DC Voltage

3. Using a Filtered PWM Signal

The filtered PWM signal can be considered as an adjustable DC voltage. It can be used to replace the variable DC voltage source in dimming control.

4. Using a Logic Signal

For applications that need to adjust the LED current in discrete steps, a logic signal can be used as shown in **Figure 4**. R_{SET} sets the minimum LED current (when the NMOS is off). R_{SET} sets how much the LED current increases when the NMOS is turned on.

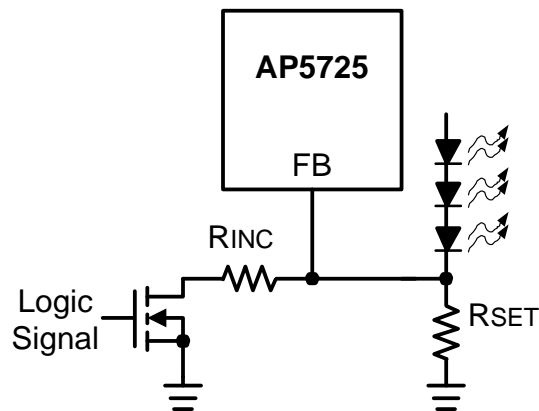

Figure 4. Dimming Control Using a Logic Signal

Applications Information (Continued)

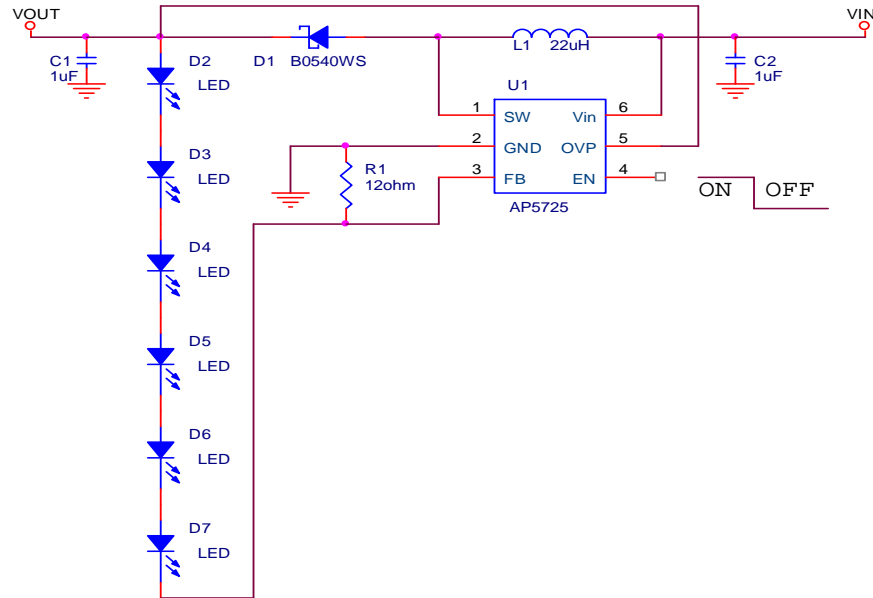

Table 2. Suggested Inductors

Vendor	Inductors (uH)	Current Rating (A)	Type	Dimensions (mm)	Series
Würth Electronics	22	0.51A	SMD	3.8X 3.8 X 1.6	744031220
GOTREND	22	0.56A	SMD	3.8 X 3.8 X 1.05	GLP3810PH220N
TAIYO YUDRN	22	0.51A	SMD	4.0 X 4.0 X 1.25	NR4012

Table 3. Suggested Capacitors for C_{IN} and C_{OUT}

Vendor	Capacitance	Type	Series
TAIYO YUDEN	1uF	SMD	TMK212 B7105MG-T

Table 4. Suggested Diodes

Vendor	Rating	Type	Series
ZETEX	40V/0.5A	SOD323	ZLLS400
DIODES	40V/0.5A	SOD323	B0540WS
DIODES	40V/0.25A	SOD523	SDM20U40

Table 5. Suggested Resistor

Vendor	Type	Series
YAGEO	SMD	FR-SK

Table 6. Suggested W-LED

Vendor	Type	Series
LITEON	SMD	LTW-C1911UC5

Ordering Information



Device	Package Code	Packaging (Note 3)	7" Tape and Reel	
			Quantity	Part Number Suffix
AP5725WG-7	W	SOT26	3000/Tape & Reel	-7
AP5725WUG-7	WU	TSOT23-6	3000/Tape & Reel	-7
AP5725FDCG-7	FDC	DFN2020C-6	3000/Tape & Reel	-7

Notes: 3. Pad layout as shown on Diodes Inc. suggested pad layout document AP02001, which can be found on our website at <http://www.diodes.com/datasheets/ap02001.pdf>.

Marking Information

(1) SOT26 and TSOT23-6

(Top View)



XX : Identification Code
Y : Year 0~9
W : Week : A~Z : 1~26 week;
a~z : 27~52 week; z represents 52 and 53 week
X : A~Z : Green

Part Number	Package	Identification Code
AP5725WG-7	SOT26	FC
AP5725WUG-7	TSOT23-6	GC

(2) DFN2020C-6

(Top View)



XX : Identification Code
Y : Year : 0~9
W : Week : A~Z : 1~26 week;
a~z : 27~52 week; z represents 52 and 53 week
X : A~Z : Green

Part Number	Package	Identification Code
AP5725FDCG-7	DFN2020C-6	GC

Package Outline Dimensions (All Dimensions in mm)

(1) Package Type: SOT26

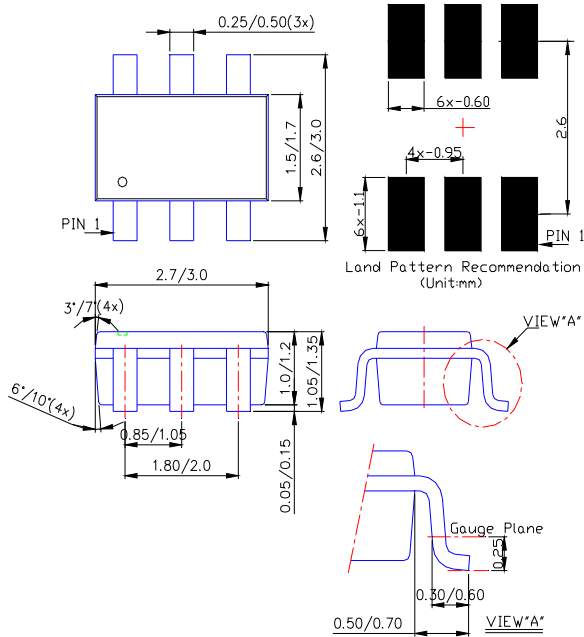

(2) Package Type: TSOT23-6



Package Outline Dimensions (Continued)

(3) Package Type: DFN2020C-6

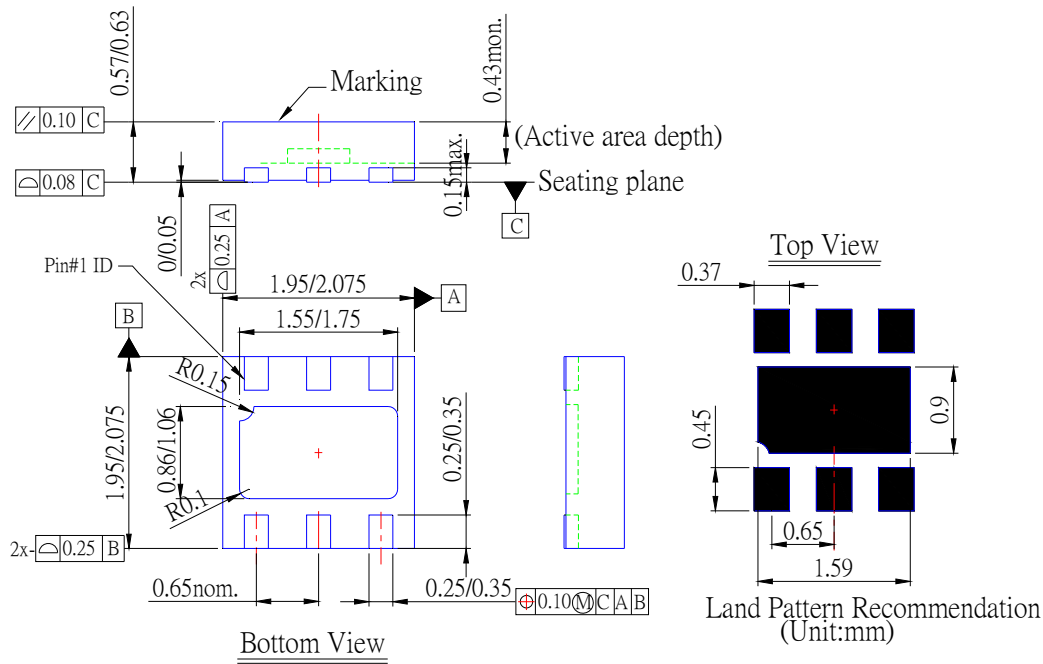

Taping Orientation

For DFN2020C-6

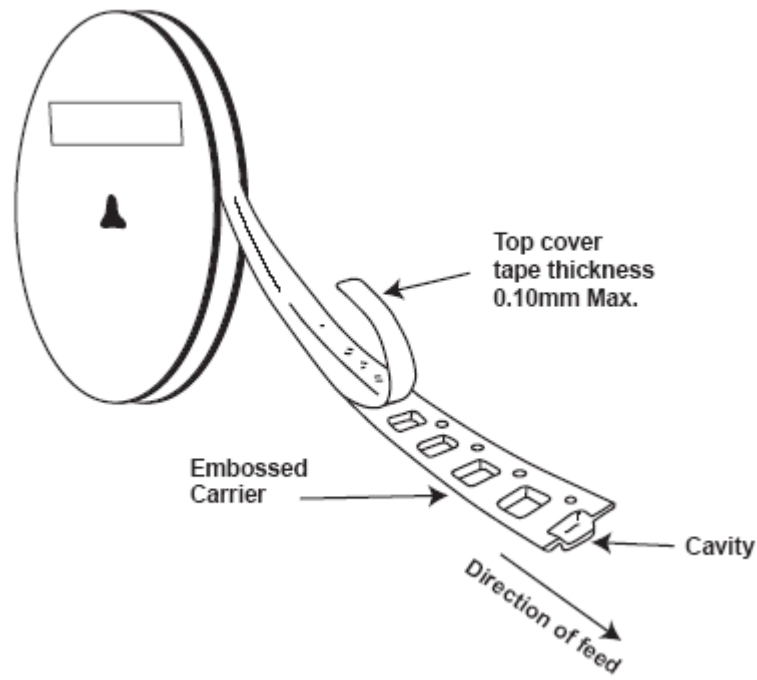
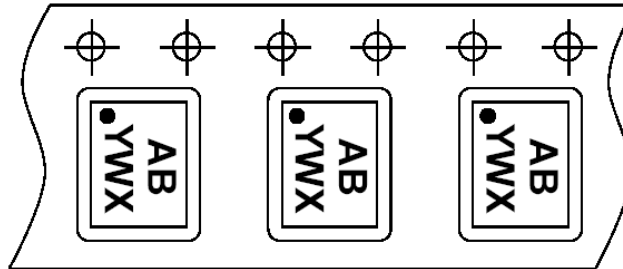

Notes: 4. The taping orientation of the other package type can be found on our website at <http://www.diodes.com/datasheets/ap02007.pdf>.

IMPORTANT NOTICE

DIODES INCORPORATED MAKES NO WARRANTY OF ANY KIND, EXPRESS OR IMPLIED, WITH REGARDS TO THIS DOCUMENT, INCLUDING, BUT NOT LIMITED TO, THE IMPLIED WARRANTIES OF MERCHANTABILITY AND FITNESS FOR A PARTICULAR PURPOSE (AND THEIR EQUIVALENTS UNDER THE LAWS OF ANY JURISDICTION).

Diodes Incorporated and its subsidiaries reserve the right to make modifications, enhancements, improvements, corrections or other changes without further notice to this document and any product described herein. Diodes Incorporated does not assume any liability arising out of the application or use of this document or any product described herein; neither does Diodes Incorporated convey any license under its patent or trademark rights, nor the rights of others. Any Customer or user of this document or products described herein in such applications shall assume all risks of such use and will agree to hold Diodes Incorporated and all the companies whose products are represented on Diodes Incorporated website, harmless against all damages.

Diodes Incorporated does not warrant or accept any liability whatsoever in respect of any products purchased through unauthorized sales channel.

Should Customers purchase or use Diodes Incorporated products for any unintended or unauthorized application, Customers shall indemnify and hold Diodes Incorporated and its representatives harmless against all claims, damages, expenses, and attorney fees arising out of, directly or indirectly, any claim of personal injury or death associated with such unintended or unauthorized application.

Products described herein may be covered by one or more United States, international or foreign patents pending. Product names and markings noted herein may also be covered by one or more United States, international or foreign trademarks.

LIFE SUPPORT

Diodes Incorporated products are specifically not authorized for use as critical components in life support devices or systems without the express written approval of the Chief Executive Officer of Diodes Incorporated. As used herein:

A. Life support devices or systems are devices or systems which:

1. are intended to implant into the body, or
2. support or sustain life and whose failure to perform when properly used in accordance with instructions for use provided in the labeling can be reasonably expected to result in significant injury to the user.

B. A critical component is any component in a life support device or system whose failure to perform can be reasonably expected to cause the failure of the life support device or to affect its safety or effectiveness.

Customers represent that they have all necessary expertise in the safety and regulatory ramifications of their life support devices or systems, and acknowledge and agree that they are solely responsible for all legal, regulatory and safety-related requirements concerning their products and any use of Diodes Incorporated products in such safety-critical, life support devices or systems, notwithstanding any devices- or systems-related information or support that may be provided by Diodes Incorporated. Further, Customers must fully indemnify Diodes Incorporated and its representatives against any damages arising out of the use of Diodes Incorporated products in such safety-critical, life support devices or systems.

Copyright © 2010, Diodes Incorporated

www.diodes.com

www.s-manuals.com