



Micropower Ultra-Sensitive Hall Effect Switch

FEATURES

- Battery Operation from 2.4V to 5.5V
- Chopper Stabilized Technology
- Micro Power Operation for Battery Applications
- Operation with North or South Pole
- High Sensitivity and High Stability of the Magnetic Switching Points
- Small RoHS-compliant, halogen-free SOT-23 or TSOT-23 packages

DESCRIPTION

The APE9101/A-HF-3 is a three-terminal Hall Effect sensor device with an output driver, mainly designed for battery operated hand-held equipment (such as cellular and cordless phones, PDAs). After power-on, the APE9101/A-HF-3 will detect and setup the operating pole (North or South) to avoid another side magnetic noise. (Patent pending). For the APE9101-HF-3, the output will be turned off in the absence of a magnetic field. While the magnetic flux density B is larger than the operating point, Bop, the output will be turned on. The output remains latched on until the flux density B drops below the release point, Brp.

Typical Application

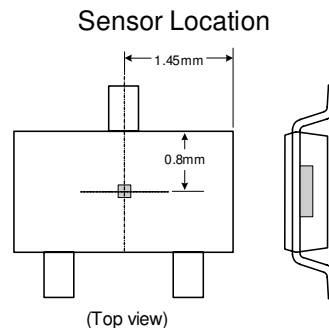
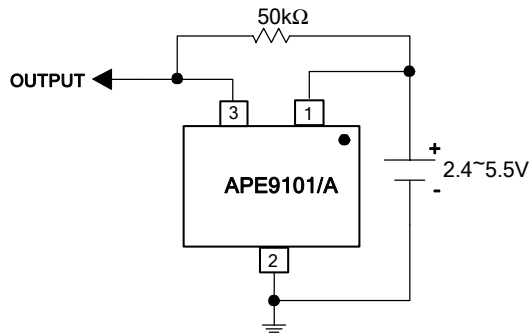

Ordering information

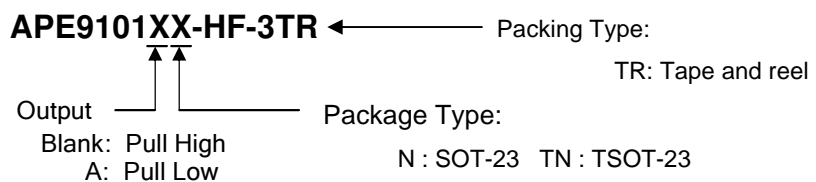

Example:

APE9101ATN-HF-3TR : output pull low, in RoHS-compliant, halogen-free TSOT-23, shipped on tape and reel (3000 pcs/reel).



Absolute Maximum Ratings (at $T_A = 25^\circ\text{C}$)

Supply Voltage Pin (V_{DD})	-0.3 to 6V
Output Voltage Pin (V_{OUT})	-0.3 to 6V
Output Current Pin (I_{OUT})	2mA
Power Dissipation (P_D)	230mW
Storage Temperature Range (T_{ST})	-65°C To 150°C
Operating Temperature Range (T_{OP})	-40°C To 85°C
Junction Temperature (T_J)	125°C
Thermal Resistance from Junction to Ambient (R_{thJA})	550°C/W

Note. R_{thJA} is measured with the PCB copper area of approximately 1 in² (Multi-layer).

Electrical Specifications

($V_{DD}=2.75\text{V}$, $T_A=25^\circ\text{C}$, unless otherwise specified)

Parameter	SYM	TEST CONDITION	MIN	TYP	MAX	UNITS
Supply Voltage	V_{DD}		2.4	-	5.5	V
Input Current		Awake State	-	2	4	mA
		Sleep State	-	7	12	uA
		Average	-	9	16	uA
Output Saturation Voltage	V_{OSAT}	$I_O=1\text{mA}$	-	0.1	0.3	V
Output Leakage Current	I_{O-LEAK}	$V_{OUT}=5.5\text{V}$, $B<B_{rp}$	-	0.01	1	uA
Output Wake-Up Time	$T_{wake-up}$		-	70	120	us
Period	T_{Period}		-	70	120	ms
Duty Cycle			-	0.1	-	%
North or South Pole Detection and Setup Time	T_{Set}	Continuous $>B_{OPs}$ or $<B_{OPN}$	-	210	400	ms

THIS PRODUCT IS SENSITIVE TO ELECTROSTATIC DISCHARGE, PLEASE HANDLE WITH CAUTION.
 USE OF THIS PRODUCT AS A CRITICAL COMPONENT IN LIFE SUPPORT OR OTHER SIMILAR SYSTEMS IS NOT AUTHORIZED.
 APEC DOES NOT ASSUME ANY LIABILITY ARISING OUT OF THE APPLICATION OR USE OF ANY PRODUCT OR CIRCUIT DESCRIBED
 HEREIN; NEITHER DOES IT CONVEY ANY LICENSE UNDER ITS PATENT RIGHTS, NOR THE RIGHTS OF OTHERS.
 APEC RESERVES THE RIGHT TO MAKE CHANGES WITHOUT FURTHER NOTICE TO ANY PRODUCTS HEREIN TO IMPROVE
 RELIABILITY, FUNCTION OR DESIGN.



Pin Assignment

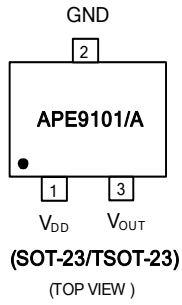

Pin Functional Descriptions

PIN SYMBOL	PIN DESCRIPTION
VDD	Power Input Pin
GND	Ground
OUTPUT	<p>APE9101</p> <p>B > B_{ops} or B < B_{opn}, Output is Low. B < B_{rps} or B > B_{rpn}, Output is High.</p> <p>APE9101A</p> <p>B > B_{ops} or B < B_{opn}, Output is High. B < B_{rps} or B > B_{rpn}, Output is Low.</p>

Magnetic Characteristics

(V_{DD} = 2.75V, T_A = 25°C, unless otherwise specified)

Parameter	SYM	TEST CONDITION	MIN	TYP	MAX	UNITS
Operating Points	B _{OPS}		-	35	55	Gauss
	B _{OPN}		-55	-35	-	
Release Points	B _{RPS}		10	25	-	
	B _{RPN}		-	-25	-10	
Hysteresis	B _{hys}		-	10	-	

1. APE9101

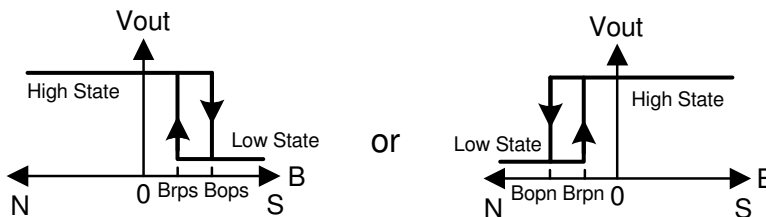

2. APE9101A

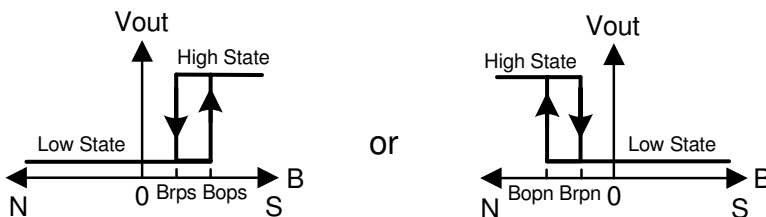



Block Diagram

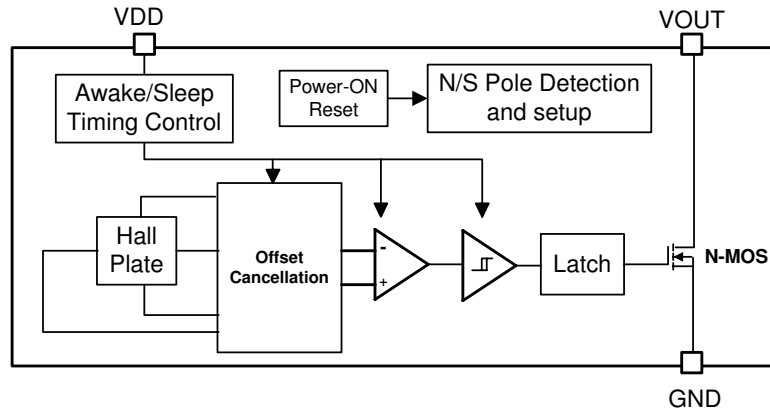

Typical Performance Characteristics

Average Supply Current vs. VDD

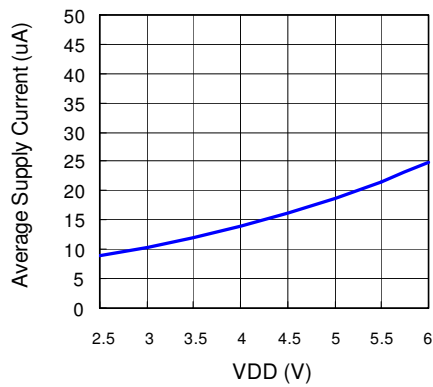

Average Supply Current vs. Temperature

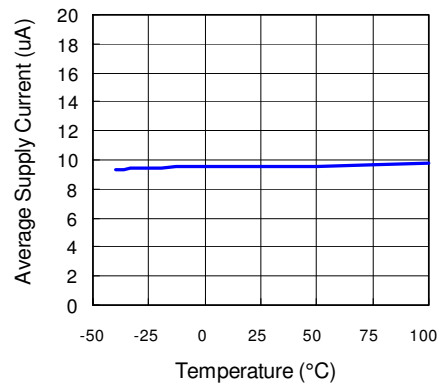

Switch Points vs. VDD

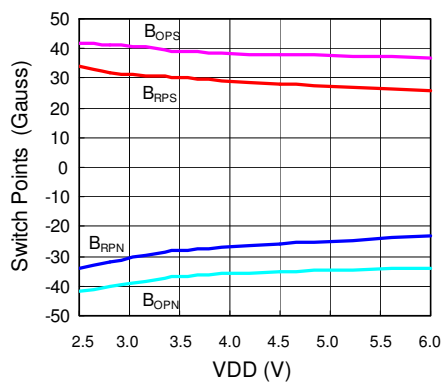

Switch Points vs. Temperature

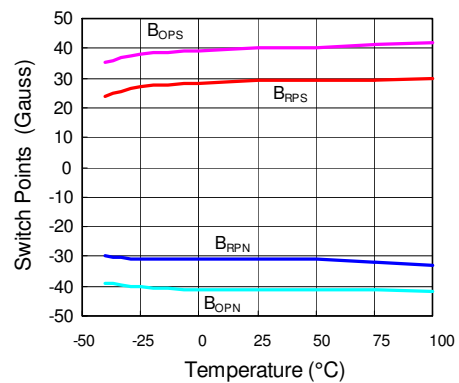



Marking Information: SOT-23 and TSOT-23

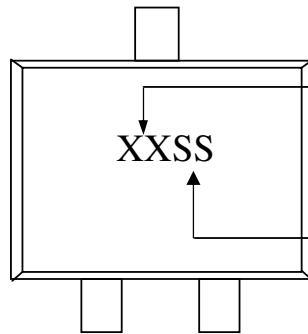

Part Number

H1 : APE9101AN/ATN-HF-3

H2 : APE9101N/TN-HF-3

Date/lot code

For details of how to convert this to standard YYWW date code format, please contact us directly.

Package Dimensions: SOT-23

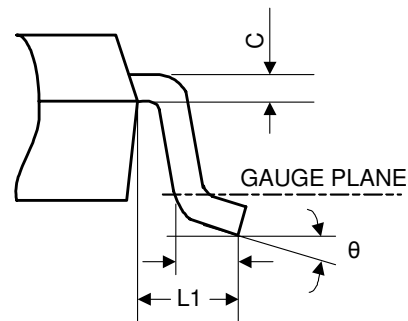
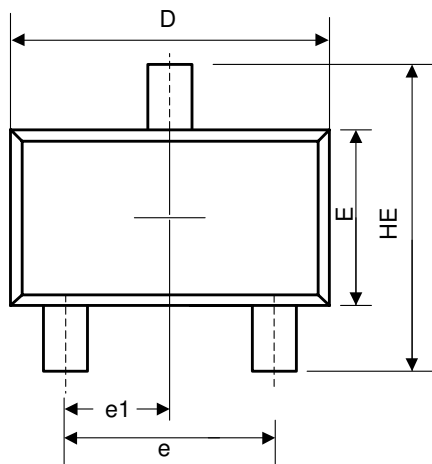

VIEW C

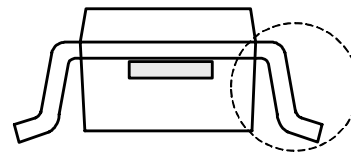
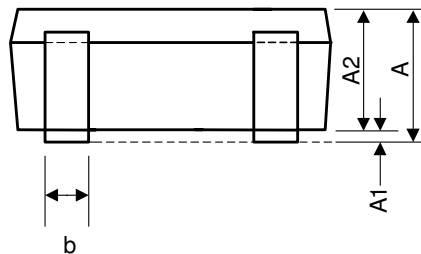

SEE VIEW C

Symbol	Dimensions In Millimeters			Dimensions In Inches		
	Min.	Nom.	Max.	Min.	Nom.	Max.
A	1.05	-	1.35	0.041	-	0.053
A1	0.05	-	0.15	0.002	-	0.006
A2	1.00	1.10	1.20	0.039	0.043	0.047
b	0.25	-	0.50	0.010	-	0.020
C	0.08	-	0.20	0.003	-	0.008
D	2.70	2.90	3.00	0.106	0.114	0.118
E	1.50	1.60	1.70	0.059	0.063	0.067
HE	2.60	2.80	3.00	0.102	0.110	0.118
L	0.30	-	0.60	0.012	-	0.024
L1	0.50	0.60	0.70	0.020	0.024	0.028
e	1.80	1.90	2.00	0.071	0.075	0.079
e1	0.85	0.95	1.05	0.033	0.037	0.041
θ	0°	5°	10°	0°	5°	10°



Package Dimensions: TSOT-23

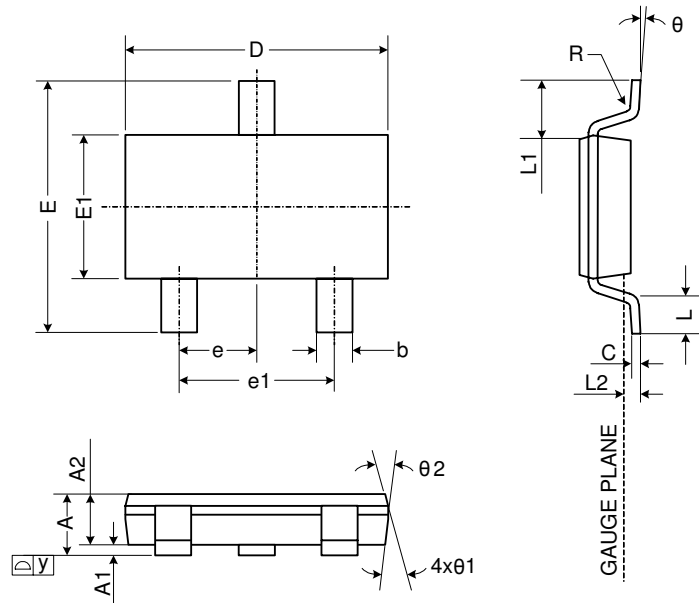

Symbol	Dimensions In Millimeters			Dimensions In Inches		
	Min.	Nom.	Max.	Min.	Nom.	Max.
A	0.75	-	0.90	0.030	-	0.035
A1	0.00	-	0.10	0.000	-	0.004
A2	0.70	0.75	0.80	0.028	0.030	0.031
b	0.35	-	0.51	0.014	-	0.020
C	0.10	-	0.25	0.004	-	0.010
D	2.80	2.90	3.00	0.110	0.114	0.118
E	2.60	2.80	3.00	0.102	0.110	0.118
E1	1.50	1.60	1.70	0.059	0.063	0.067
e	0.95 BSC.			0.037		
e1	1.90 BSC.			0.075		
L	0.37	-	-	0.015	-	-
L1	0.60 REF.			0.024		
L2	0.25 BSC.			0.010		
y	-	-	0.10	-	-	0.004
R	0.10	-	-	0.004	-	-
theta	0°	-	8°	0°	-	8°
theta1	7° NOM.			7° NOM.		
theta2	5° NOM.			5° NOM.		

www.s-manuals.com