

IA4054

Standalone Linear Li-Ion Battery Charger with Thermal Regulation in ThinSOT

Features

- Programmable Charge Current Up to 800mA
- No MOSFET, Sense Resistor or Blocking Diode Required
- Complete Linear Charger in ThinSOTTM Package for
- Single Cell Lithium-Ion Batteries
- Constant-Current/Constant-Voltage Operation with
- Thermal Regulation* to Maximize Charge Rate
- Without Risk of Overheating
- Charges Single Cell Li-Ion Batteries Directly from USB Port
- Preset 4.2V Charge Voltage with 1% Accuracy
- Automatic Recharge
- 60uA Supply Current in Shutdown
- 2.9V Trickle Charge Threshold
- Two sides of LED showing
- Available in 6-Lead SOT-23 Package

Applications

- Charger for Li-Ion Coin Cell Batteries
- Portable MP3 Players, Wireless Headsets
- Bluetooth Applications
- Multifunction Wristwatches

Description

The IA4054 is a complete constant-current/constant-voltage linear charger for single cell lithium-ion batteries. Its ThinSOT package and low external component count make the IA4054 ideally suited for portable applications. Furthermore, the IA4054 is specifically designed to work within USB power specifications.

No external sense resistor is needed, and no blocking diode is required due to the internal MOSFET architecture. Thermal feedback regulates the charge current to limit the die temperature during high power operation or high ambient temperature. The charge voltage is fixed at 4.2V, and the charge current can be programmed externally with a single resistor. The IA4054 automatically terminates the charge cycle when the charge current drops to 1/10th the programmed value after the final float voltage is reached.

When the input supply (wall adapter or USB supply) is removed, the IA4054 automatically enters a low current state, dropping the battery drain current to less than 1uA. The IA4054 can be put into shutdown mode, reducing the supply current to 60uA. Other features include charge current monitor, undervoltage lockout, automatic recharge and a status pin to indicate charge termination and the presence of an input voltage.

The IA4054 converters are available in the industry standard SOT-23-6 power packages (or upon request).

Order Information

IA4054 ① ② :

SYMBOL	DESCRIPTION
①	Denotes Output voltage: 4.2V
②	Denotes Package Types: E: SOT-23-6

Typical Application

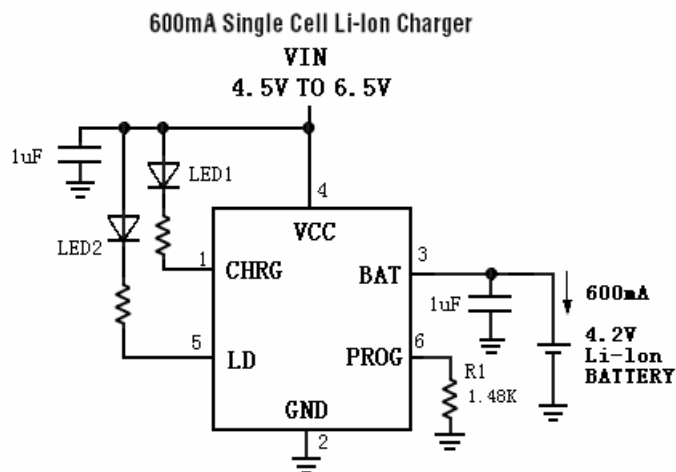

Complete Charge Cycle (750mAh Battery)

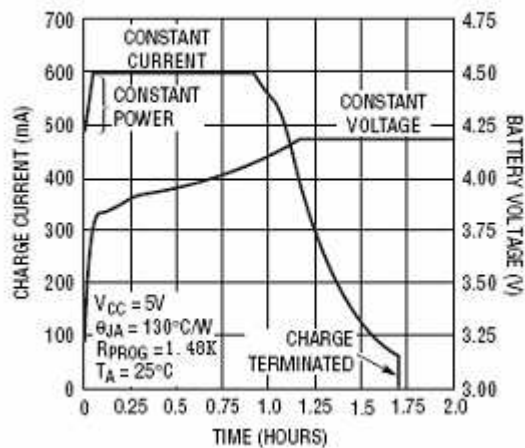

Pin Assignment

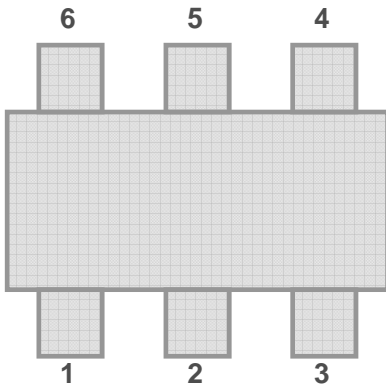

PIN NUMBER SOT-23- 6	PIN NAME	FUNCTION
1	CHRG	Open-Drain Charge Status Output
2	GND	Ground
3	BAT	Charge Current Output
4	PROG	Positive Input Supply Voltage.
5	LD	Open-Drain Charge Status Output
6	V _{CC}	Charge Current Program, Charge Current Monitor and Shutdown Pin

Absolout Maximum Ratings

- Input Supply Voltage (VCC) -0.3V to 10V
- PROG..... - 0.3V to VCC + 03V
- BAT -0.3V to 8V
- CHRG..... -0.3V to 10V
- BAT Short-Circuit Duration Continuous
- BAT Pin Current 800mA
- PROG Pin Current 800uA
- Maximum Junction Temperature 125°C
- Operating Ambient Temperature Range..... -40°C to 85°C
- Storage Temperature Range -65 °Cto 125°C
- Lead Temperature (Soldering, 10 sec)..... 300°C

Electrical Characteristics

Operating Conditions: $T_A=25^{\circ}\text{C}$, $V_{CC}=5\text{V}$ unless otherwise specified.

SYMBOL	PARAMETER	CONDITIONS	MIN	TYP	MAX	UNITS
V_{CC}	Input Supply Voltage		4.5	5.0	6.5	V
I_{CC}	Input Supply Current	Charge Mode, $R_{PROG} = 10\text{k}$ Standby Mode (Charge Terminated) I Shutdown Mode (R_{PROG} Not Connected, $V_{CC} < V_{BAT}$, or $V_{CC} < V_{UV}$)		70 45 65		μA μA μA
V_{FLOAT}	Regulated Output (Float) Voltage	$0^{\circ}\text{C} \leq T_A \leq 85^{\circ}\text{C}$, $I_{BAT} = 40\text{mA}$	4.15	4.2	4.24	V
I_{BAT}	BAT Pin Current	$R_{PROG} = 10\text{k}$, Current Mode $R_{PROG} = 2\text{k}$, Current Mode Standby Mode, $V_{BAT} = 4.2\text{V}$ Shutdown Mode (R_{PROG} Not Connected) Sleep Mode, $V_{CC} = 0\text{V}$	83 410	89 445 7.3 7.2 0.3	97 470	mA mA μA μA μA
I_{TRIKL}	Trickle Charge Current	$V_{BAT} < V_{TRIKL}$, $R_{PROG} = 2\text{k}$	15	39	65	mA
V_{ASD}	$V_{CC} - V_{BAT}$ Lockout Threshold Voltage	V_{CC} from Low to High V_{CC} from High to Low		5 18		mV
I_{TERM}	C/10 Termination Current Threshold	$R_{PROG} = 2\text{k}$		45		mA
V_{PROG}	PROG Pin Voltage	$R_{PROG} = 10\text{k}$, Current Mode	0.94	1.02	1.08	V
R_{ON}	Efficiency	Power FET "ON" Resistance (Between V_{CC} and BAT)		660		$\text{m}\Omega$

Application Information

PIN ASSIGNMENT

CHRG (Pin 1): Open-Drain Charge Status Output. When the battery is charging, the CHRG pin is pulled low by an internal N-channel MOSFET. When the charge cycle is completed, high impedance is forced to the CHRG pin and LD (pin 5) is pulled low, indicating an “AC present” condition. When the IA4054 detects an reverse battery ($V_{BAT} > V_{CC}$) lockout or no AC condition, Both CHRG and LD are forced high impedance.

GND (Pin 2): Ground.

BAT (Pin 3): Charge Current Output. It should be bypassed with at least a 1uF capacitor. It Provides charge current to the battery and regulates the final float voltage to 4.2V. An internal precision resistor divider from this pin sets the float voltage which is disconnected in shutdown mode.

Vcc (Pin 4): Positive Input Supply Voltage. Provides power to the charger. VCC can range from 4.25V to 6.5V and should be bypassed with at least a 1uF capacitor. When VCC drops to within 30mV of the BAT pin voltage, the IA4054

enters shutdown mode, dropping IBAT to less than 2 uA.

LD(Pin 5): Open-Drain Charge Status Output. See CHRG pin (Pin 1).

PROG (Pin 6): Charge Current Program, Charge Current Monitor and Shutdown Pin. The charge current is programmed by connecting a 1% resistor, RPROG, to ground. When charging in constant-current mode, this pin serves to 1V. In all modes, the voltage on this pin can be used to measure the charge current using the following formula: $IBAT = (V_{PROG}/R_{PROG}) * 890$. The PROG pin can also be used to shut down the charger. Disconnecting the program resistor from ground allows a weak current to pull the PROG pin high. When it reaches the 1.21V shutdown threshold voltage, the charger enters shutdown mode, charging stops and the input supply current drops to 65uA. Reconnecting RPROG to ground will return the charger to normal operation.

Packaging Information

SOT-23-6 Package Outline Dimension

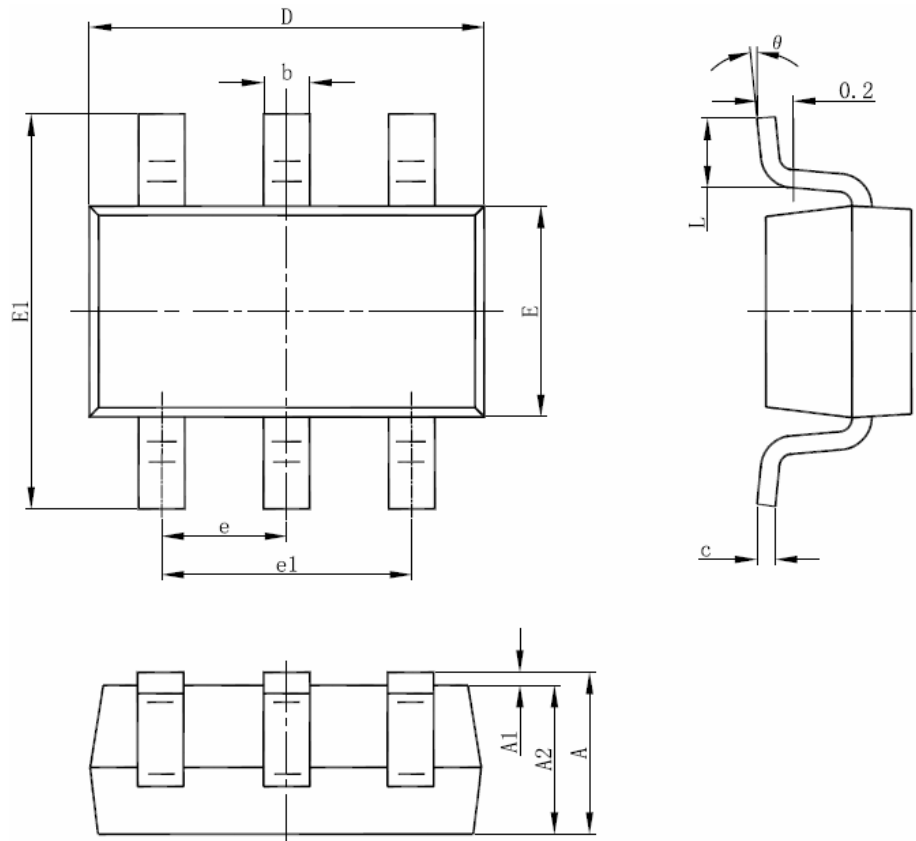

Symbol	Dimensions In Millimeters		Dimensions In Inches	
	Min	Max	Min	Max
A	1.050	1.250	0.041	0.049
A1	0.000	0.100	0.000	0.004
A2	1.050	1.150	0.041	0.045
b	0.300	0.500	0.012	0.020
c	0.100	0.200	0.004	0.008
D	2.820	3.020	0.111	0.119
E	1.500	1.700	0.059	0.067
E1	2.650	2.950	0.104	0.116
e	0.950(BSC)		0.037(BSC)	
e1	1.800	2.000	0.071	0.079
L	0.300	0.600	0.012	0.024

www.s-manuals.com