

General Description

This Trench MOSFET has better characteristics, such as fast switching time, low on resistance, low gate charge and excellent avalanche characteristics. It is mainly suitable for portable equipment.

FEATURES

- $V_{DSS} = -30V$, $I_D = -3A$
- Drain-Source ON Resistance
 $R_{DS(ON)} = 80m\ \Omega$ (Max.) @ $V_{GS} = -10V$
 $R_{DS(ON)} = 140m\ \Omega$ (Max.) @ $V_{GS} = -4.5V$
- Super High Dense Cell Design

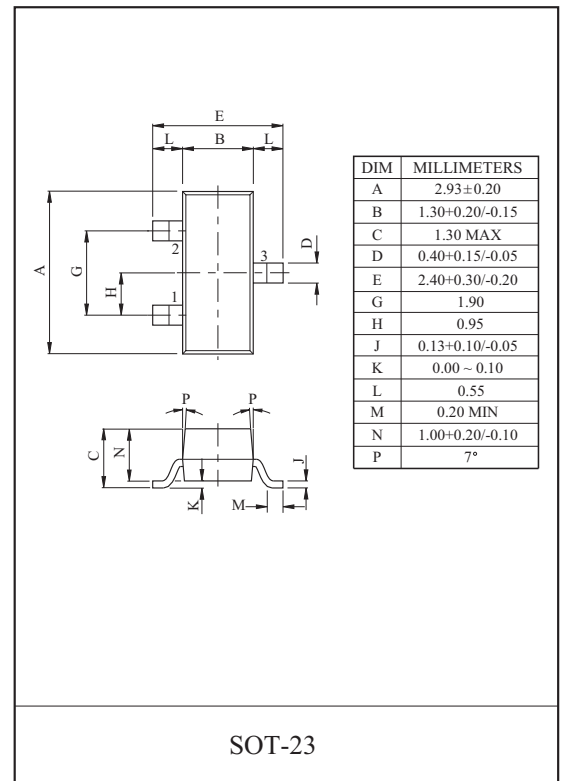

MAXIMUM RATING (Ta=25 °C)

CHARACTERISTIC		SYMBOL	P-Ch	UNIT
Drain-Source Voltage		V_{DSS}	-30	V
Gate-Source Voltage		V_{GSS}	±20	V
Drain Current	DC@T _A =25 °C	I_D^*	-3	A
	DC@T _A =70 °C		-2.5	
	Pulsed	I_{DP}	-12	
Drain-Source-Diode Forward Current		I_S	-1.25	A
Drain Power Dissipation	T _A =25 °C	P_D^*	1.25	W
	T _A =70 °C		0.8	
Maximum Junction Temperature		T _j	150	°C
Storage Temperature Range		T _{stg}	-55 ~ 150	°C
Thermal Resistance, Junction to Ambient		R _{thJA} *	100	°C/W

Note : *Surface Mounted on FR4 Board

PIN CONNECTION (TOP VIEW)

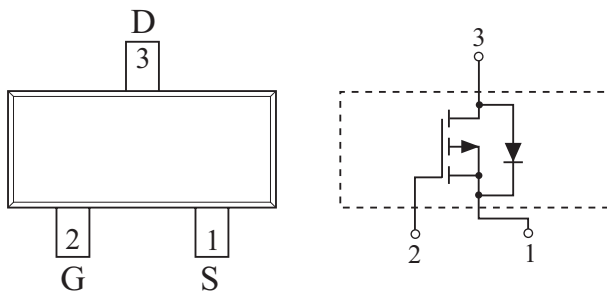

Marking

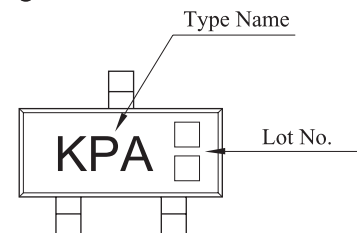

KMB3D0P30SA

ELECTRICAL CHARACTERISTICS (Ta=25 °C)

CHARACTERISTIC	SYMBOL	TEST CONDITION	MIN.	TYP.	MAX.	UNIT
Static						
Drain-Source Breakdown Voltage	BV_{DSS}	$I_{DS}=-250\mu A, V_{GS}=0V,$	-30	-	-	V
Drain Cut-off Current	I_{DSS}	$V_{GS}=0V, V_{DS}=-24V$	-	-	-1	μA
		$V_{GS}=0V, V_{DS}=-24V, T_j=55\text{ }^\circ C$	-	-	-10	
Gate Leakage Current	I_{GSS}	$V_{GS}=\pm 20V, V_{DS}=0V$	-	-	± 100	nA
Gate Threshold Voltage	V_{th}	$V_{DS}=V_{GS}, I_D=250\mu A$	-1.0	-	-	V
Drain-Source ON Resistance	$R_{DS(ON)}^*$	$V_{GS}=-10V, I_D=-3A$	-	64	80	m Ω
		$V_{GS}=-4.5V, I_D=-2.5A$	-	103	140	
Forward Transconductance	g_{fs}^*	$V_{DS}=-10V, I_D=-3A$	-	4.5	-	S
Dynamic						
Input Capacitance	C_{iss}	$V_{DS}=-15V, V_{GS}=0V, f=1MHz,$	-	565	-	pF
Output Capacitance	C_{oss}		-	126	-	
Reverse Transfer Capacitance	C_{rss}		-	75	-	
Total Gate Charge	Q_g^*	$V_{DS}=-15V, V_{GS}=-10V, I_D=-3A$	-	10	15	nC
Gate-Source Charge	Q_{gs}^*		-	1.9	-	
Gate-Drain Charge	Q_{gd}^*		-	2	-	
Turn-On Delay Time	$t_{d(on)}^*$	$V_{DD}=-15V, V_{GS}=-10V$ $I_D=-1A, R_G=6\ \Omega$	-	10	20	ns
Turn-On Rise Time	t_r^*		-	9	20	
Turn-Off Delay Time	$t_{d(off)}^*$		-	27	50	
Turn-Off Fall Time	t_f^*		-	7	16	
Source-Drain Diode Ratings						
Source-Drain Forward Voltage	V_{SDF}^*	$V_{GS}=0V, I_{DR}=-1.25A$	-	-	-1.2	V
NOTE 1) * : Pulse Test : Pulse width <300 μs , Duty cycle < 2%						

KMB3D0P30SA

Fig1. $I_D - V_{DS}$

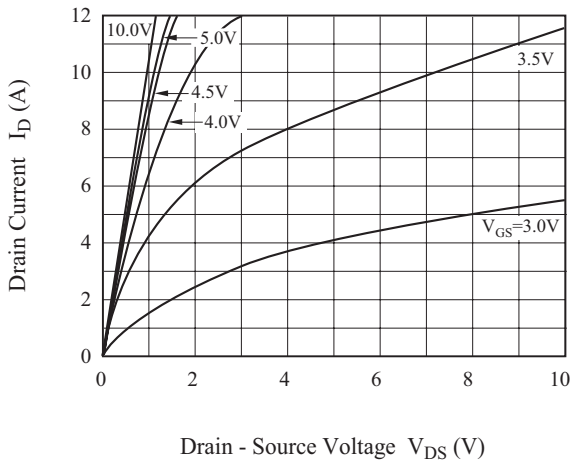

Fig2. $R_{DS-ON} - I_D$

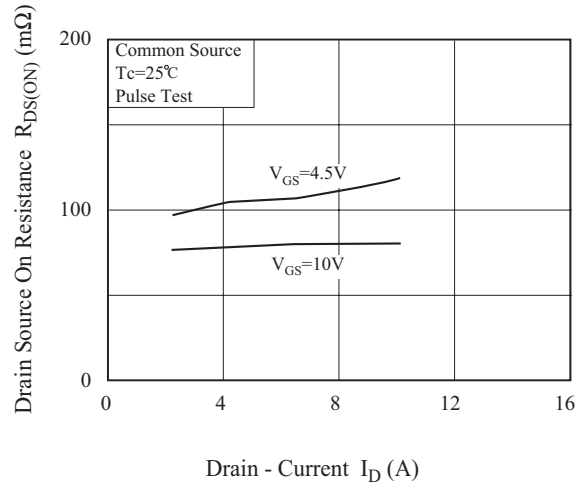

Fig3. $I_D - V_{GS}$

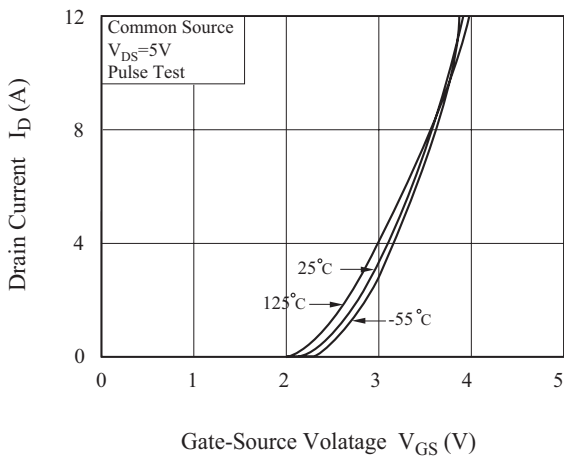

Fig4. $R_{DS(on)} - T_j$

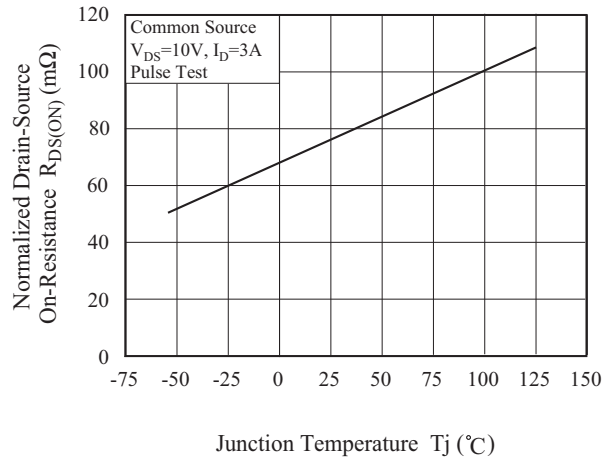

Fig5. $V_{th} - T_j$

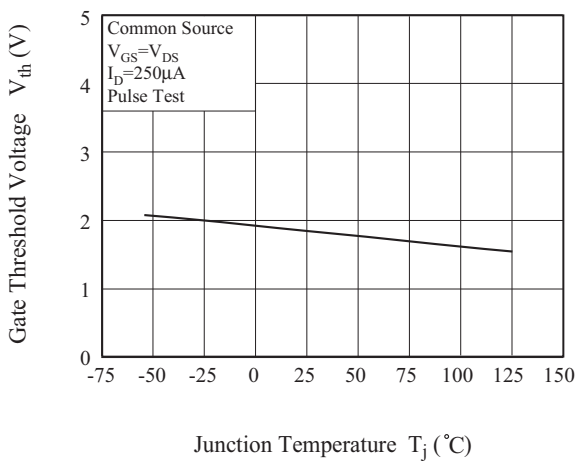
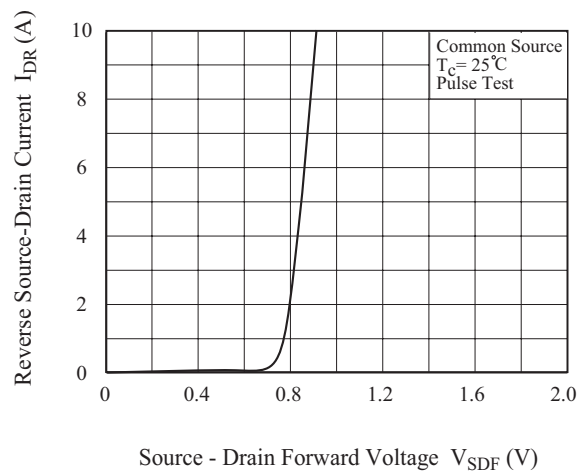

Fig6. $I_{DR} - V_{SDF}$



KMB3D0P30SA

Fig7. Safe Operation Area

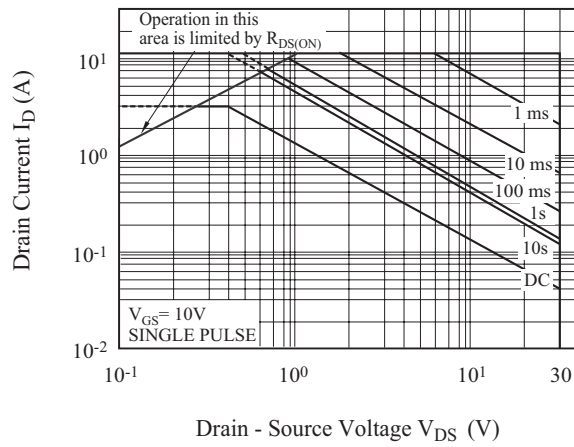

Fig8. Transient Thermal Response Curve

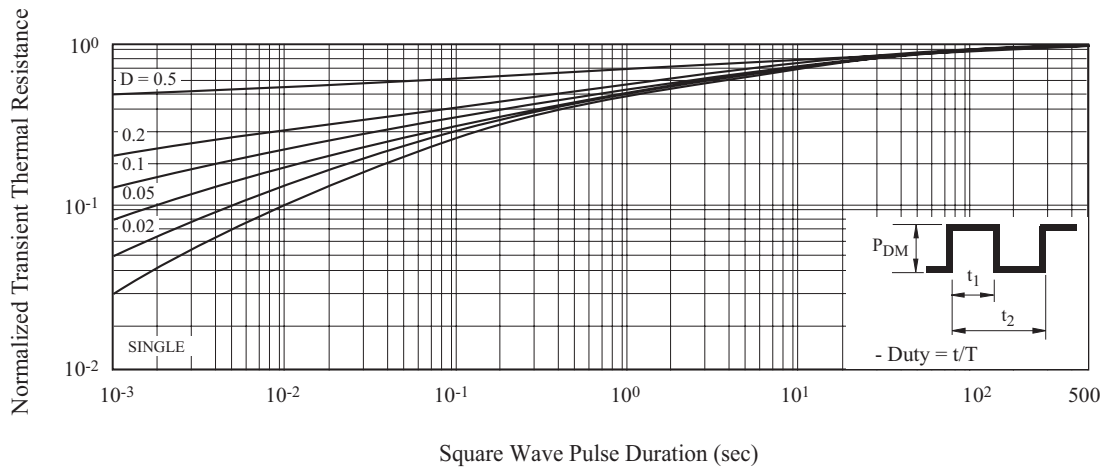

Fig9. Gate Charge Circuit and Wave Form

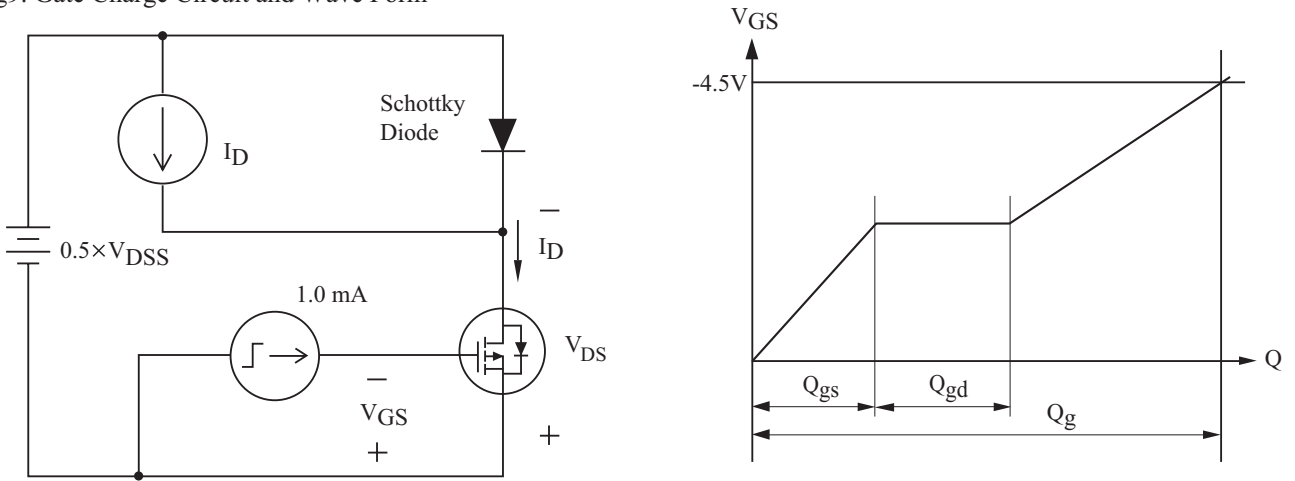
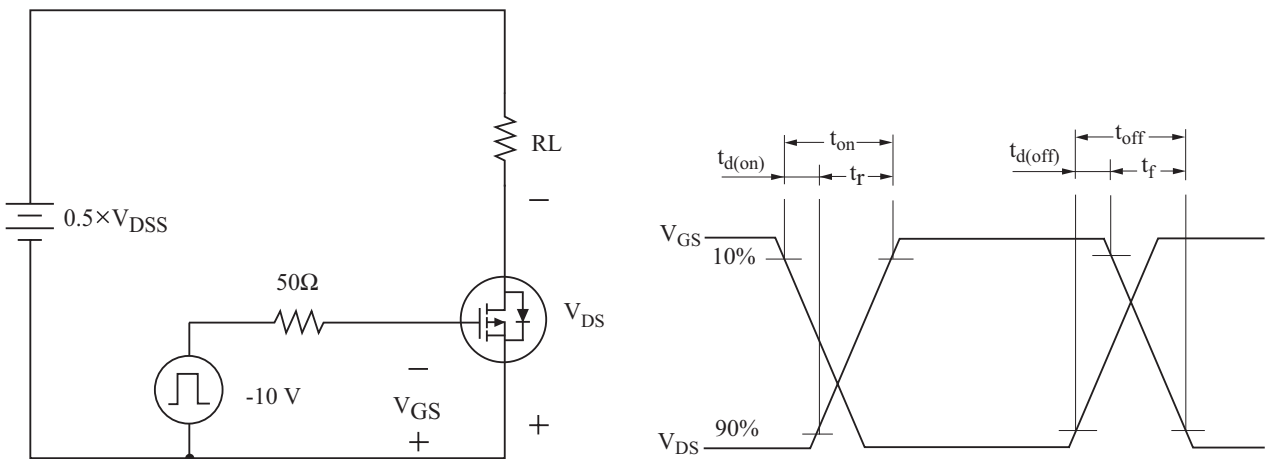

Fig10. Resistive Load Switching



www.s-manuals.com