

## LM2788

# 120mA High Efficiency Step-Down Switched Capacitor Voltage Converter

### General Description

The LM2788 switched capacitor step-down DC/DC converter efficiently produces a 120mA regulated low-voltage rail from a 2.6V to 5.5V input. Fixed output voltage options of 1.5V, 1.8V, and 2.0V are available. The LM2788 uses multiple fractional gain configurations to maximize conversion efficiency over the entire input voltage and output current ranges. Also contributing to high overall efficiency is the extremely low supply current of the LM2788: 32µA operating unloaded and 0.1µA in shutdown.

The optimal external component requirements of the LM2788 solution minimize size and cost, making the part ideal for Li-Ion and other battery powered designs. Two 1µF flying capacitors and two 10µF bypass capacitors are all that are required, and no inductors are needed.

The LM2788 also features noise-reducing soft-start circuitry, short-circuit protection and over-temperature protection.

### Features

- Output voltage options:  
2.0V ± 5%, 1.8V ± 5%, 1.5V ± 6%
- 120mA output current capability
- Multi-Gain and Gain Hopping for Highest Possible Efficiency - up to 90% Efficient
- 2.6V to 5.5V input range
- Low operating supply current: 32µA
- Shutdown supply current: 0.1µA
- Thermal and short circuit protection
- Available in an 8-Pin MSOP Package

### Applications

- Cellular Phones
- Pagers
- H/PC and P/PC Devices
- Portable Electronic Equipment
- Handheld Instrumentation

### Typical Application Circuit

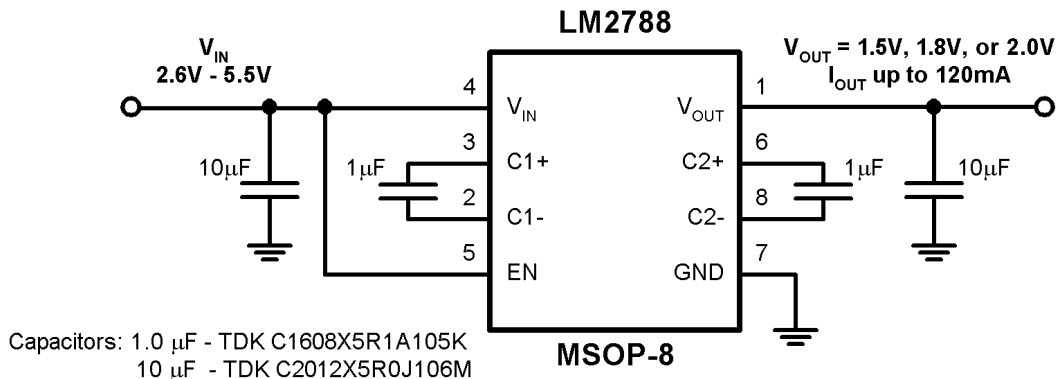

20044401

## Connection Diagram

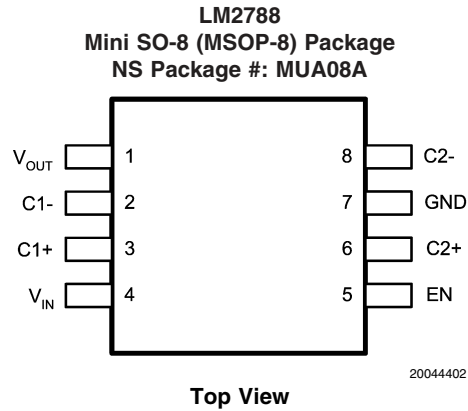

## Pin Description

Pin	Name	Description
1	$V_{OUT}$	Regulated Output Voltage
2	C1-	First Flying Capacitor: Negative Terminal
3	C1+	First Flying Capacitor: Positive terminal
4	$V_{IN}$	Input voltage. Recommended $V_{IN}$ Range: 2.6V to 5.5V
5	EN	Enable. Logic Input. High voltage = ON, Low voltage = SHUTDOWN
6	C2+	Second Flying-Capacitor: Positive Terminal
7	GND	Ground Connection
8	C2-	Second Flying Capacitor: Negative Terminal

## Ordering Information

Output Voltage	Ordering Information	Package Type	Package Marking	Supplied as
1.50V	LM2788MM-1.5	MSOP-8	S30B	1000 units on Tape-and Reel
	LM2788MMX-1.5		S30B	3500 units onTape-and-Reel
1.80V	LM2788MM-1.8		S23B	1000 units on Tape-and Reel
	LM2788MMX-1.8		S23B	3500 units on Tape-and Reel
2.00V	LM2788MM-2.0		S24B	1000 units on Tape-and Reel
	LM2788MMX-2.0		S24B	3500 units on Tape-and Reel

**Absolute Maximum Ratings** (Notes 1,

2)

If Military/Aerospace specified devices are required, please contact the National Semiconductor Sales Office/Distributors for availability and specifications.

$V_{IN}$ , EN pins: Voltage to Ground (Note 3)	-0.3V to 5.6V
Junction Temperature ( $T_{J-MAX-ABS}$ )	150°C
Continuous Power Dissipation (Note 4)	Internally Limited
$V_{OUT}$ Short-Circuit to GND Duration (Note 4)	Unlimited
Storage Temperature Range	-65°C to 150°C
Lead Temperature (Soldering, 5 Sec.)	260°C
ESD Rating (Note 5)	
Human-body model:	2 kV
Machine model	200V

**Operating Ratings** (Notes 1, 2)

Input Voltage Range	2.6V to 5.5V
Recommended Output Current Range	0mA to 120mA
Junction Temperature Range	-40°C to 125°C
Ambient Temperature Range (Note 6)	-40°C to 85°C

**Thermal Information**

Junction-to-Ambient Thermal Resistance, MSOP-8 Package ( $\theta_{JA}$ ) (Note 7)	220°C/W
---	---------

**Electrical Characteristics** (Notes 2, 8) Limits in standard typeface and typical values apply for  $T_J = 25^\circ\text{C}$ . Limits in **boldface** type apply over the operating junction temperature range. Unless otherwise specified:  $2.6 \leq V_{IN} \leq 5.5\text{V}$ ,  $V(EN) = V_{IN}$ ,  $C_1 = C_2 = 1\mu\text{F}$ ,  $C_{IN} = C_{OUT} = 10\mu\text{F}$ . (Note 9)

Symbol	Parameter	Conditions	Min	Typ	Max	Units
<b>LM2788-1.8, LM2788-2.0</b>						
$V_{OUT}$	Output Voltage Tolerance	$2.8\text{V} \leq V_{IN} \leq 4.2\text{V}$ $0\text{mA} \leq I_{OUT} \leq 120\text{mA}$	<b>-5</b>		<b>+5</b>	% of $V_{OUT(nom)}$ (Note 10)
		$4.2\text{V} \leq V_{IN} \leq 5.5\text{V}$ $0\text{mA} \leq I_{OUT} \leq 120\text{mA}$	-6		+6	
<b>LM2788-1.5</b>						
$V_{OUT}$	Output Voltage Tolerance	$2.8\text{V} \leq V_{IN} \leq 4.2\text{V}$ $0\text{mA} \leq I_{OUT} \leq 120\text{mA}$	<b>-6</b>		<b>+6</b>	% of $V_{OUT(nom)}$ (Note 10)
		$4.2\text{V} \leq V_{IN} \leq 5.5\text{V}$ $0\text{mA} \leq I_{OUT} \leq 120\text{mA}$	-6		+6	
<b>All Output Voltage Options</b>						
$I_Q$	Operating Supply Current	$I_{OUT} = 0\text{mA}$		32	<b>50</b>	$\mu\text{A}$
$I_{SD}$	Shutdown Supply Current	$V(EN) = 0\text{V}$		0.1	<b>2</b>	$\mu\text{A}$
$V_R$	Output Voltage Ripple	LM2788-1.8: $V_{IN} = 3.6\text{V}$ , $I_{OUT} = 120\text{mA}$		20		$\text{mV}_{p-p}$
$E_{PEAK}$	Peak Efficiency	LM2788-1.8: $V_{IN} = 3.0\text{V}$ , $I_{OUT} = 60\text{mA}$		90		%
$E_{AVG}$	Average Efficiency over Li-Ion Input Voltage Range (Note 11)	LM2788-1.5: $3.0 \leq V_{IN} \leq 4.2\text{V}$ , $I_{OUT} = 60\text{mA}$		76		%
		LM2788-1.8: $3.0 \leq V_{IN} \leq 4.2\text{V}$ , $I_{OUT} = 60\text{mA}$		82		
		LM2788-2.0: $3.0 \leq V_{IN} \leq 4.2\text{V}$ , $I_{OUT} = 60\text{mA}$		75		
$t_{ON}$	Turn-On Time	$V_{IN} = 3.6\text{V}$ , $I_{OUT} = 120\text{mA}$ (Note 12)		0.4		ms
$f_{SW}$	Switching Frequency			500		kHz
$I_{SC}$	Short-Circuit Current	$V_{IN} = 3.6\text{V}$ , $V_{OUT} = 0\text{V}$		25		mA
<b>Enable Pin (EN) Characteristics</b>						
$V_{IH}$	EN pin Logic-High Input		<b>0.9</b>		$V_{IN}$	V
$V_{IL}$	EN pin Logic-Low Input		<b>0</b>		<b>0.4</b>	V
$I_{EN}$	EN pin input current	$V_{EN} = 0\text{V}$		0		nA
		$V_{EN} = 5.5\text{V}$		30		

**Note 1:** Absolute Maximum Ratings indicate limits beyond which damage to the component may occur. Operating Ratings are conditions under which operation of the device is guaranteed. Operating Ratings do not imply guaranteed performance limits. For guaranteed performance limits and associated test conditions, see the Electrical Characteristics tables.

**Note 2:** All voltages are with respect to the potential at the GND pin.

**Note 3:** Voltage on the EN pin must not be brought above  $V_{IN} + 0.3\text{V}$ .

## Electrical Characteristics

(Notes 2, 8) Limits in standard typeface and typical values apply for  $T_J = 25^\circ\text{C}$ .

Limits in **boldface** type apply over the operating junction temperature range. Unless otherwise specified:  $2.6 \leq V_{IN} \leq 5.5\text{V}$ ,  $V(\text{EN}) = V_{IN}$ ,  $C_1 = C_2 = 1\mu\text{F}$ ,  $C_{IN} = C_{OUT} = 10\mu\text{F}$ . (Note 9) (Continued)

**Note 4:** Thermal shutdown circuitry protects the device from permanent damage.

**Note 5:** The Human body model is a 100 pF capacitor discharged through a 1.5 k $\Omega$  resistor into each pin. The machine model is a 200pF capacitor discharged directly into each pin.

**Note 6:** Maximum ambient temperature ( $T_{A-\text{MAX}}$ ) is dependent on the maximum operating junction temperature ( $T_{J-\text{MAX-OP}} = 125^\circ\text{C}$ ), the maximum power dissipation of the device in the application ( $P_{D-\text{MAX}}$ ), and the junction-to ambient thermal resistance of the part/package in the application ( $\theta_{JA}$ ), as given by the following equation:  $T_{A-\text{MAX}} = T_{J-\text{MAX-OP}} - (\theta_{JA} \times P_{D-\text{MAX}})$ . The ambient temperature operating rating is provided merely for convenience. This part may be operated outside the listed  $T_A$  rating, so long as the junction temperature of the device does not exceed the maximum operating rating of  $125^\circ\text{C}$ .

**Note 7:** Junction-to-ambient thermal resistance is a highly application and board-layout dependent. In applications where high maximum power dissipation exists, special care must be paid to thermal dissipation issues. For more information on these topics, please refer to the **Power Dissipation** section of this datasheet.

**Note 8:** All room temperature limits are 100% tested or guaranteed through statistical analysis. All limits at temperature extremes are guaranteed by correlation using standard Statistical Quality Control methods (SQC). All limits are used to calculate Average Outgoing Quality Level (AOQL). Typical numbers are not guaranteed, but do represent the most likely norm.

**Note 9:**  $C_{\text{FLY}}$ ,  $C_{\text{IN}}$ , and  $C_{\text{OUT}}$ : Low-ESR Surface-Mount Ceramic Capacitors (MLCCs) used in setting electrical characteristics

**Note 10:** Nominal output voltage ( $V_{\text{OUT}}(\text{nom})$ ) is the target output voltage of the part, as given by the output-voltage-option identifier. See **Ordering Information** table for available options.

**Note 11:** Efficiency is measured versus  $V_{\text{IN}}$ , with  $V_{\text{IN}}$  being swept in small increments from 3.0V to 4.2V. The average is calculated from these measurements results. Weighting to account for battery voltage discharge characteristics ( $V_{\text{BAT}}$  vs. Time) is not done in computing the average.

**Note 12:** Turn-on time is measured from when the EN signal is pulled high until the output voltage crosses 90% of its final value.

## Block Diagram

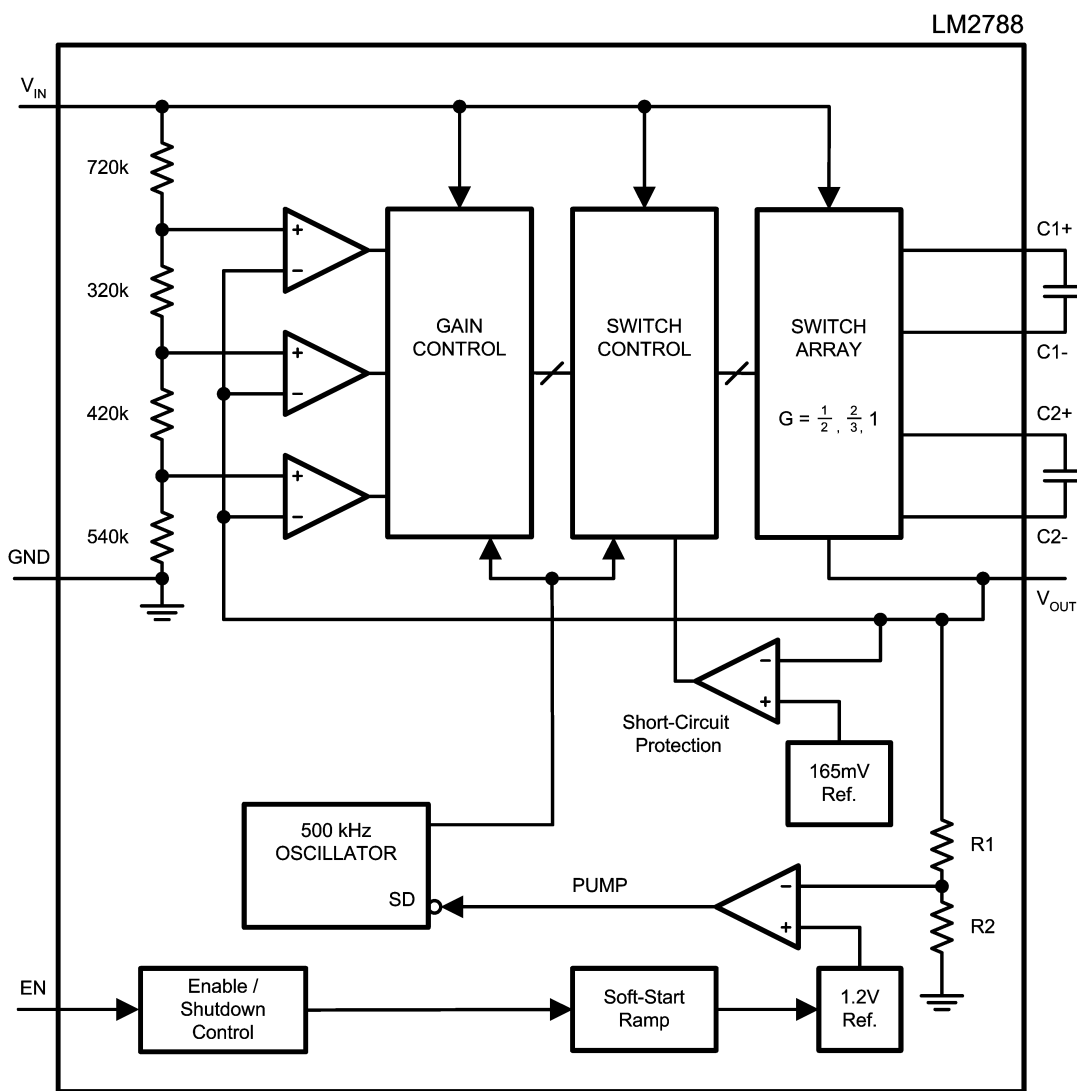

## Typical Performance Characteristics

Unless otherwise specified:  $C_{IN} = 10\mu\text{F}$ ,  $C_1 = 1.0\mu\text{F}$ ,  $C_2 = 1.0\mu\text{F}$ ,  $C_{OUT} = 10\mu\text{F}$ ,  $T_A = 25^\circ\text{C}$ . Capacitors are low-ESR multi-layer ceramic capacitors (MLCC's).

**Output Voltage vs. Input Voltage:  
LM2788-1.5 (1mA)**

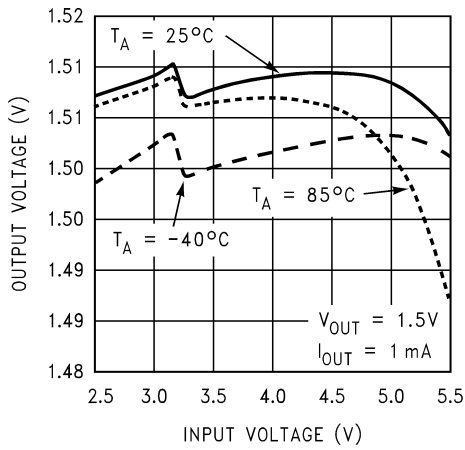

**Output Voltage vs. Input Voltage:  
LM2788-1.5 (120mA)**

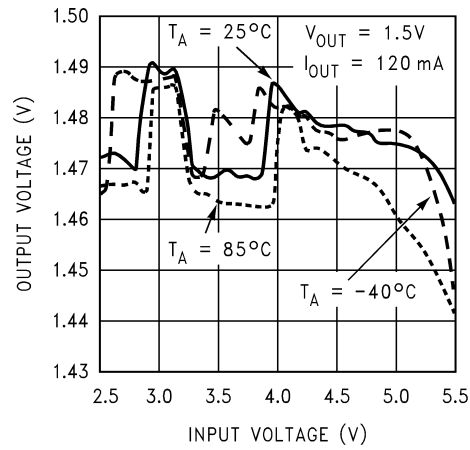

**Output Voltage vs. Input Voltage:  
LM2788-1.8 (1mA)**

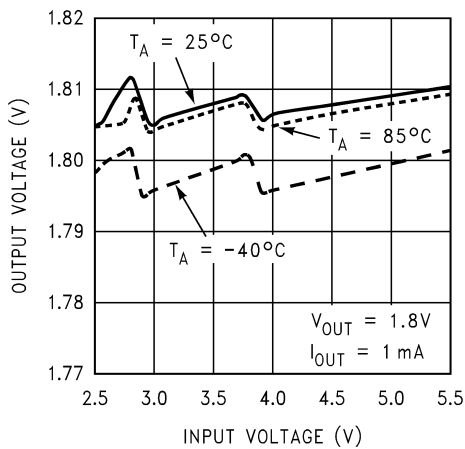

**Output Voltage vs. Input Voltage:  
LM2788-1.8 (120mA)**

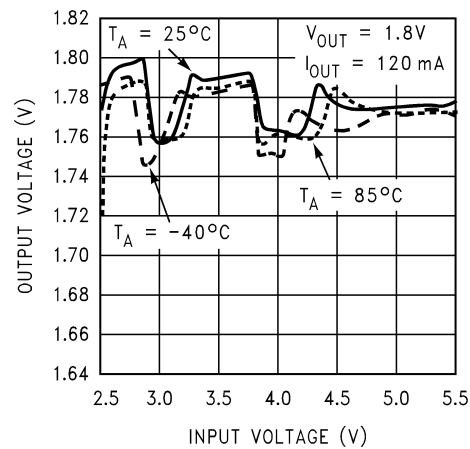

**Output Voltage vs. Input Voltage:  
LM2788-2.0 (1mA)**

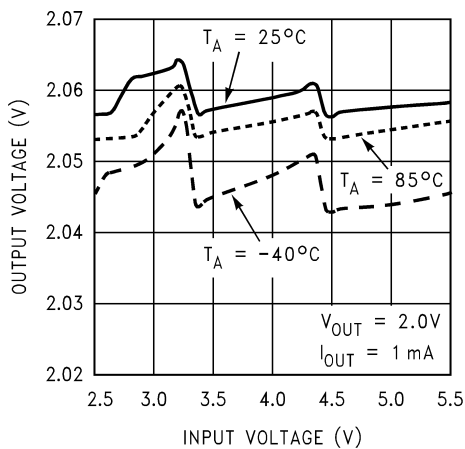

**Output Voltage vs. Input Voltage:  
LM2788-2.0 (120mA)**

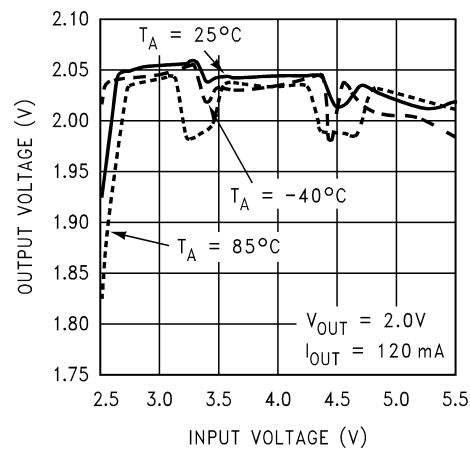

# Typical Performance Characteristics (Continued)

**Efficiency vs. Input Voltage: LM2788-1.5**

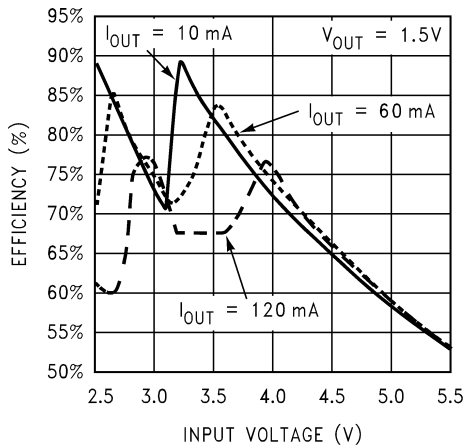

**Efficiency vs. Output Current: LM2788-1.5**

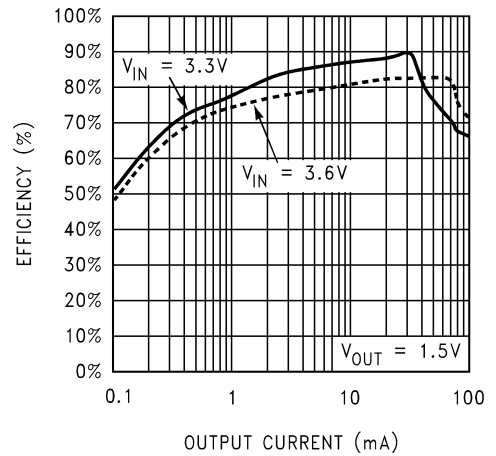

**Efficiency vs. Input Voltage: Lm2788-1.8**

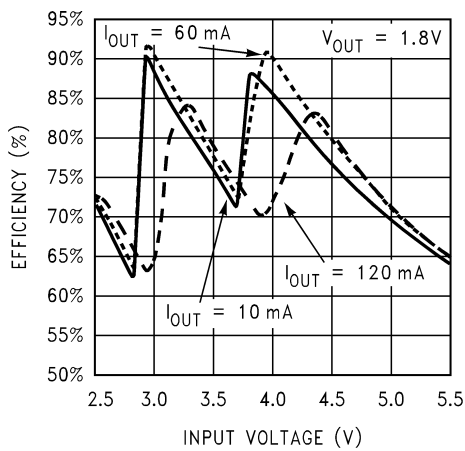

**Efficiency vs. Output Current: LM2788-1.8**

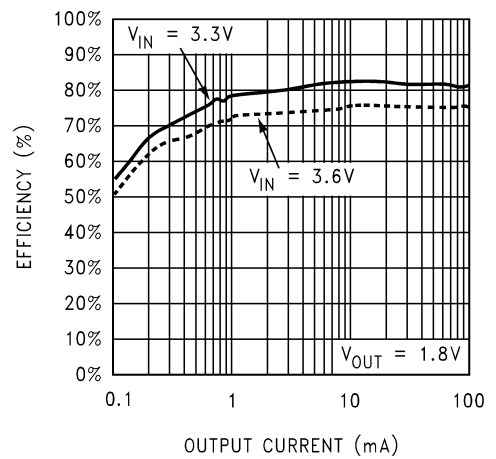

**Efficiency vs. Input Voltage: LM2788-2.0**

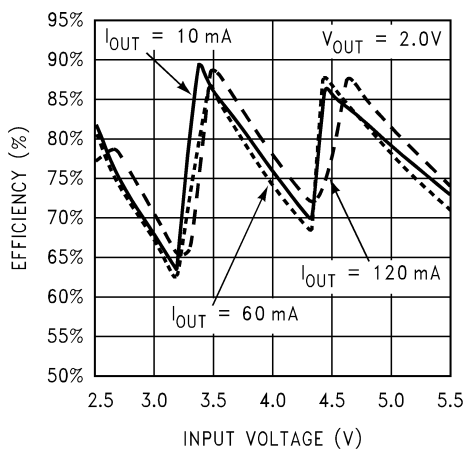

**Efficiency vs. Output Current: LM2788-2.0**

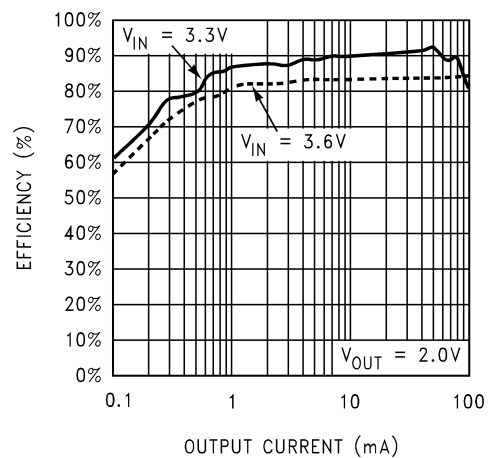

# Typical Performance Characteristics (Continued)

**Output Voltage Ripple vs. Output Current**

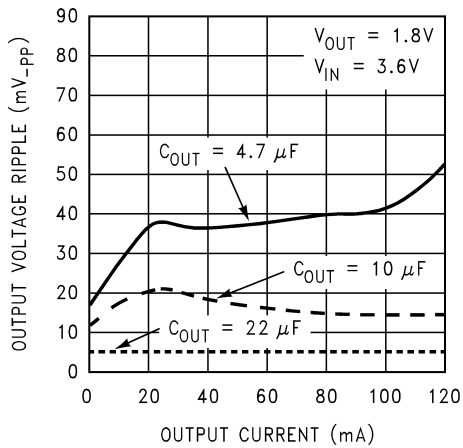

20044421

**Output Voltage Ripple vs. Input Voltage**

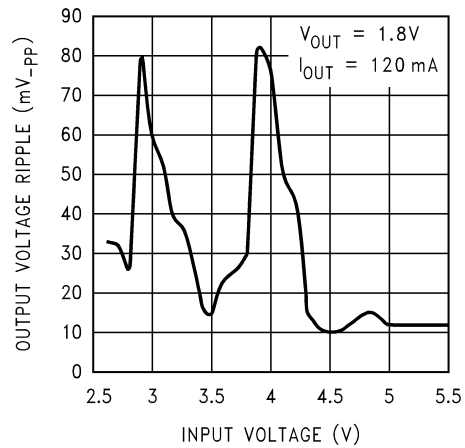

20044419

**Output Voltage Ripple**

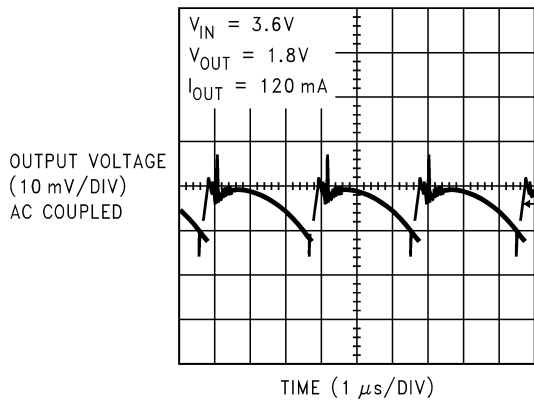

20044406

**Short Circuit Current**

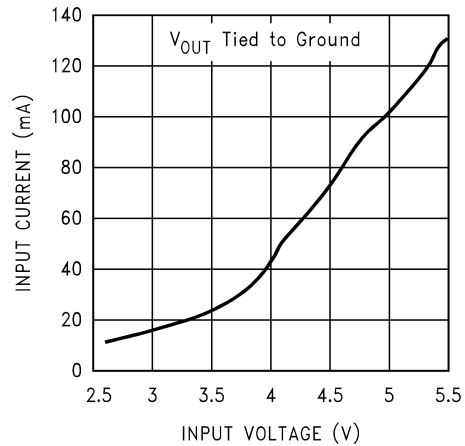

20044420

**Start Up Waveform**

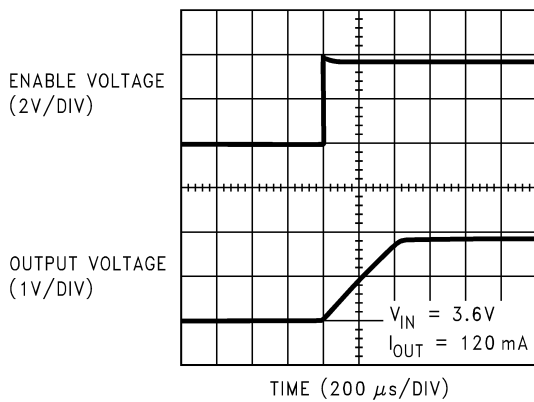

20044404

**Transient Load Response**

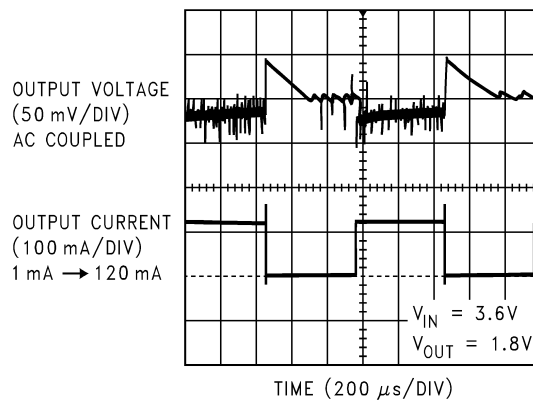

20044405

## Operation Description

### OVERVIEW

The LM2788 is a switched capacitor converter that produces a regulated low-voltage output. The core of the part is the highly efficient charge pump that utilizes multiple fractional gains and pulse-frequency modulated (PFM) switching to minimize power losses over wide input voltage and output current ranges. A description of the principal operational characteristics of the LM2788 is broken up into the following sections: **PFM Regulation**, **Fractional Multi-Gain Charge Pump**, and **Gain Selection for Optimal Efficiency**. Each of these sections refers to the block diagram presented on the previous page.

### PFM REGULATION

The LM2788 achieves tightly regulated output voltages with pulse-frequency modulated (PFM) regulation. PFM simply means the part only pumps when it needs to. When the output voltage is above the target regulation voltage, the part idles and consumes minimal supply-current. In this state, the load current is supplied solely by the charge stored on the output capacitor. As this capacitor discharges and the output voltage falls below the target regulation voltage, the charge pump activates. Charge/current is delivered to the output (supplying the load and boosting the voltage on the output capacitor).

The primary benefit of PFM regulation is when output currents are light and the part is predominantly in the low-supply-current idle state. Net supply current is minimal because the part only occasionally needs to refresh the output capacitor by activating the charge pump, and the supply current it consumes.

### FRACTIONAL MULTI-GAIN CHARGE PUMP

The core of the LM2788 is a two-phase charge pump controlled by an internally generated non-overlapping clock. The charge pump operates by using the external flying capacitors, C1 and C2, to transfer charge from the input to the output. During the charge phase, which doubles as the PFM 'idle state', the flying capacitors are charged by the input supply. The charge pump will be in this state until the output voltage drops below the target regulation voltage, triggering the charge pump to activate so that it can deliver charge to the output. Charge transfer is achieved in the pump phase, where the fully charged flying capacitors are connected to the output so that the charge they hold can supply the load and recharge the output capacitor.

Input, output, and intermediary connections of the flying capacitors are made with internal MOS switches. The LM2788 utilizes two flying capacitors and a versatile switch network to achieve several fractional voltage gains:  $1/2$ ,  $2/3$ , and 1. With this gain-switching ability, it is as if the LM2788 is three-charge-pumps-in-one. The 'active' charge pump at any given time is the one that will yield the highest efficiency given the input and output conditions present.

### GAIN SELECTION AND GAIN HOPPING FOR OPTIMAL EFFICIENCY

The ability to switch gains based on input and output conditions results in optimal LM2788 efficiency throughout the operating ranges of the part. Charge-pump efficiency is derived in the following two ideal equations (supply current and other losses are neglected for simplicity):

$$I_{IN} = G \times I_{OUT}$$

$$E = (V_{OUT} \times I_{OUT}) \div (V_{IN} \times I_{IN}) = V_{OUT} \div (G \times V_{IN})$$

In the equations, G represents the charge pump gain. Efficiency is optimal as  $G \times V_{IN}$  approaches  $V_{OUT}$ . Optimal efficiency is achieved when gain is able to adjust depending on input and output voltage conditions. Due to the nature of charge pumps, G cannot adjust continuously, which would be ideal from an efficiency standpoint. But G can be a set of simple quantized ratios, allowing for a good degree of efficiency optimization.

The gain set of the LM2788 consists of the gains  $1/2$ ,  $2/3$ , and 1. An internal input voltage range detector, along with the nominal output voltage of the given LM2788 option, determines what is to be referred to as the 'base gain' of the part,  $G_B$ . The base gain is the default gain configuration of the part at a given  $V_{IN}$ . Table 1 lists  $G_B$  of the LM2788-1.8 over the input voltage range. (For the remainder of this discussion, the 1.8V option of the LM2788 will be used as an example. The other voltage options operate under the same principles as the 1.8V version, the gain-transitions merely occur at different voltage levels.)

TABLE 1. LM2788-1.8 Base Gain ( $G_B$ ) vs.  $V_{IN}$

Input Voltage	Base Gain ( $G_B$ )
2.6V - 2.9V	1
2.9V - 3.8V	$2/3$
3.8V - 5.5V	$1/2$

Table 1 shows the efficiency of the LM2788-1.8 versus input voltage, with output currents of 10mA and 120mA. The base gain regions ( $G_B$ ) are separated and labeled. There is also a set of ideal efficiency gradients,  $E_{IDEAL(G=xx)}$ , showing the ideal efficiency of a charge pumps with gains of  $1/2$ ,  $2/3$ , and 1. These curves were generated using the ideal efficiency equation presented above.

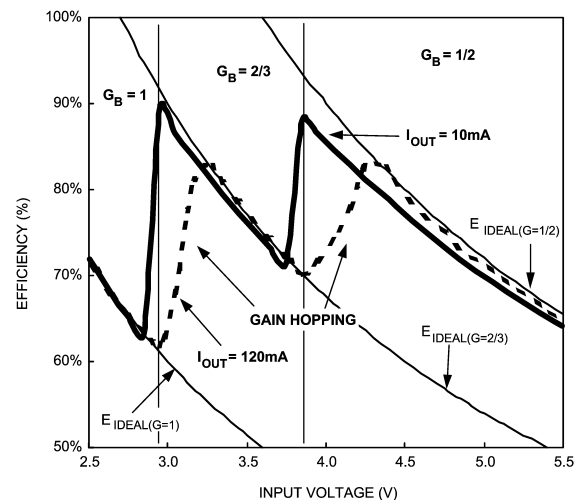

20044422

FIGURE 1. Efficiency of LM2788-1.8 with 10mA and 120mA output currents Base-gain ( $G_B$ ) regions are separated and labeled Ideal efficiency curves of charge pumps with  $G=1/2$ ,  $2/3$ , and 1 are included ( $E_{IDEAL(G=1)}$ ,  $E_{IDEAL(G=2/3)}$ ,  $E_{IDEAL(G=1/2)}$ )

The 10mA-load efficiency curve in Figure 1 closely resembles the ideal Efficiency-vs.-Input- Voltage curves that correspond to each of the base-gain regions. The same



## Operation Description (Continued)

holds true for the other base-gain regions. At the base-gain transitions ( $V_{IN} = 2.9V, 3.8V$ ), the 10mA curve makes sharp transitions as the part switches base-gains. The 10mA load curve gives a clear picture of how base-gain affects overall converter efficiency. With a 10mA output current, the gain of the LM2788-1.8 is equal to the base-gain over the entire operating input voltage range. Additionally, with a 10mA load, internal supply current has a minimal impact on efficiency (Supply current does have a small affect: it is why the 10mA load curve is slightly below the ideal efficiency gradients in each of the base-gain regions).

The 120mA-load curve in Figure 1 illustrates the effect of gain hopping on converter efficiency. Gain hopping is implemented to overcome output voltage droop that results from charge-pump non-idealities. In an ideal charge pump, the output voltage is equal to the product of the gain and the input voltage. Non-idealities such as finite switch resistance, capacitor ESR, and other factors result in the output of practical charge pumps being below the ideal value, however. This output droop is typically modeled as an output resistance,  $R_{OUT}$ , because the magnitude of the droop increases linearly with load current.

$$\text{Ideal Charge Pump: } V_{OUT} = G \times V_{IN}$$

$$\text{Real Charge Pump: } V_{OUT} = (G \times V_{IN}) - (I_{OUT} \times R_{OUT})$$

The LM2788 compensates for output voltage droop under high load conditions by gain hopping: when the base-gain is not sufficient to keep the output voltage in regulation, the part will temporarily switch up to the next highest gain setting to provide an intermittent boost in output voltage. When the output voltage is sufficiently boosted, the gain configuration reverts back to the base-gain setting. If the load remains high, the part will continue to hop back and forth between the base-gain and the next highest gain setting, and the output voltage will remain in regulation. In contrast to the base-gain decision, which is made based on the input voltage, the decision to gain hop is made by monitoring the voltage at the output of the part.

The efficiency curve of the LM2788-1.8 with a 120mA output current, also contained in Figure 1, shows the effect that gain hopping has on efficiency. Comparing the 120mA load curve to the 10mA load curve, it is plain to see that to the right of the base-gain transitions, the efficiency of the 120mA curve increases gradually whereas the 10mA curve makes a sharp transition. The base-gain of both curves is the same for both loads. The difference comes in gain hopping. With the 120mA load, the part will spend a percentage of time in the base-gain setting and the rest of the time in the next-highest gain setting. The percentage of time gain hopping decreases as the input voltage rises, as less gain-hopping boost is required with increased input voltage. When the input voltage in a given base-gain region is large enough so that no extra boost from gain hopping is required, the 120mA-load efficiency curve mirrors the 10mA efficiency curve.

**TABLE 2. LM2788-1.8 Gain Hopping Regions**

Input Voltage	Base Gain ( $G_B$ )	Gain Hop Setting
3.0V - 3.3V	$\frac{2}{3}$	1
3.8V - 4.4V	$\frac{1}{2}$	$\frac{2}{3}$

Gain hopping contributes to the overall high efficiency of the LM2788. Gain hopping only occurs when required for keeping the output voltage in regulation. This allows the LM2788

to operate in the higher efficiency base-gain setting as much as possible. Gain hopping also allows the base-gain transitions to be placed at input voltages that are as low as practically possible. This maximizes the peaks, and minimizes the valleys, of the efficiency 'saw-tooth' curves, again maximizing total solution efficiency.

### SHUTDOWN

The LM2788 is in shutdown mode when the voltage on the active-low logic enable pin (EN) is low. In shutdown, the LM2788 draws virtually no supply current. When in shutdown, the output of the LM2788 is completely disconnected from the input, and will be 0V unless driven by an outside source.

In some applications, it may be desired to disable the LM2788 and drive the output pin with another voltage source. This can be done, but the voltage on the output pin of the LM2788 must not be brought above the input voltage. The output pin will draw a small amount when driven externally due the internal feedback resistor divider connected between  $V_{OUT}$  and GND.

### SOFT START

The LM2788 employs soft start circuitry to prevent excessive input inrush currents during startup. The output voltage is programmed to rise from 0V to the nominal output voltage in approximately 400 $\mu$ s (typ.). With the input voltage established, soft-start is engaged when a part is enabled by pulling the voltage on the EN pin high. Soft-start also engages when voltage is established simultaneously to the  $V_{IN}$  and EN pins

### THERMAL SHUTDOWN

Protection from overheating-related damage is achieved with a thermal shutdown feature. When the junction temperature rises to 150°C (typ.), the part switches into shutdown mode. The LM2788 disengages thermal shutdown when the junction temperature of the part is reduced to 130°C (typ.). Due to its high efficiency, the LM2788 should not activate thermal shutdown (or exhibit related thermal cycling) when the part is operated within specified input voltage, output current, and ambient temperature operating ratings.

### SHORT-CIRCUIT PROTECTION

The LM2788 short-circuit protection circuitry that protects the device in the event of excessive output current and/or output shorts to ground. A graph of 'Short-Circuit Current vs. Input Voltage' is provided in the **Performance Characteristics** section.

## Application Information

### OUTPUT VOLTAGE RIPPLE

The voltage ripple on the output of the LM2788 is highly dependent on the application conditions. The output capacitor, the input voltage, and the output current each play a significant part in determining the output voltage ripple. Due to the complexity of LM2788 operation, providing equations or models to approximate the magnitude of the ripple cannot be easily accomplished. The following general statements can be made however

The output capacitor will have a significant effect on output voltage ripple magnitude. Ripple magnitude will typically be linearly proportional to the output capacitance present. A

## Application Information (Continued)

low-ESR ceramic capacitor is recommended on the output to keep output voltage ripple low. Placing multiple capacitors in parallel can reduce ripple significantly, both by increasing capacitance and reducing ESR. When capacitors are in parallel, ESR is in parallel as well. The effective net ESR is determined according to the properties of parallel resistance. Two identical capacitors in parallel have twice the capacitance and half the ESR as compared to a single capacitor of the same make. On a similar note, if a large-value, high-ESR capacitor (tantalum, for example) is to be used as the primary output capacitor, the net output ESR can be significantly reduced by placing a low-ESR ceramic capacitor in parallel with this primary output capacitor.

Ripple is increased when the LM2788 is gain hopping. Thus, in the presence of high currents, ripple is likely to vary significantly over the input voltage, depending on whether or not the part is gain hopping.

### CAPACITORS

The LM2788 requires 4 external capacitors for proper operation. Surface-mount multi-layer ceramic capacitors are recommended. These capacitors are small, inexpensive and have very low equivalent series resistance (ESR,  $\leq 15\text{m}\Omega$  typ.). Tantalum capacitors, OS-CON capacitors, and aluminum electrolytic capacitors generally are not recommended for use with the LM2788 due to their high ESR, as compared to ceramic capacitors.

For most applications, ceramic capacitors with X7R or X5R temperature characteristic are preferred for use with the LM2788. These capacitors have tight capacitance tolerance (as good as  $\pm 10\%$ ), hold their value over temperature (X7R:  $\pm 15\%$  over  $-55^\circ\text{C}$  to  $125^\circ\text{C}$ ; X5R:  $\pm 15\%$  over  $-55^\circ\text{C}$  to  $85^\circ\text{C}$ ), and typically have little voltage coefficient.

Capacitors with Y5V and/or Z5U temperature characteristic are generally not recommended for use with the LM2788. These types of capacitors typically have wide capacitance tolerance ( $+80\%$ ,  $-20\%$ ), vary significantly over temperature (Y5V:  $+22\%$ ,  $-82\%$  over  $-30^\circ\text{C}$  to  $+85^\circ\text{C}$  range; Z5U:  $+22\%$ ,  $-56\%$  over  $+10^\circ\text{C}$  to  $+85^\circ\text{C}$  range), and have poor voltage coefficients. Under some conditions, a nominal  $1\mu\text{F}$  Y5V or Z5U capacitor could have a capacitance of only  $0.1\mu\text{F}$ . Such detrimental deviation is likely to cause these Y5V and Z5U of capacitors to fail to meet the minimum capacitance requirements of the LM2788.

The table below lists some leading ceramic capacitor manufacturers.

Manufacturer	Contact Information
AVX	<a href="http://www.avx.com">www.avx.com</a>
Murata	<a href="http://www.murata.com">www.murata.com</a>
Taiyo-Yuden	<a href="http://www.t-yuden.com">www.t-yuden.com</a>
TDK	<a href="http://www.component.tdk.com">www.component.tdk.com</a>
Vishay-Vitramon	<a href="http://www.vishay.com">www.vishay.com</a>

### OUTPUT CAPACITOR

The output capacitor of the LM2788 plays an important part in LM2788 performance. In typical high-current applications, a  $10\mu\text{F}$  low-ESR (ESR = equivalent series resistance) ceramic capacitor is recommended for use. For lighter loads, the output capacitance may be reduced (capacitance as low as  $1\mu\text{F}$  for output currents  $\leq 60\text{mA}$  is usually acceptable). The performance of the part should be evaluated with spe-

cial attention paid to efficiency and output ripple to ensure the capacitance chosen on the output yields performance suitable for the application. In extreme cases, excessive ripple could cause control loop instability, severely affecting the performance of the part. If excessive ripple is present, the output capacitance should be increased.

The ESR of the output capacitor affects charge pump output resistance, which plays a role in determining output current capability. Both output capacitance and ESR affect output voltage ripple (See Output Voltage Ripple section, above). For these reasons, a low-ESR X7R/X5R ceramic capacitor is the capacitor of choice for the LM2788 output.

### FLYING CAPACITORS

The flying capacitors ( $C_1$  and  $C_2$ ) transfer charge from the input to the output, and thus are like the engine of the charge pump. Low-ESR ceramic capacitors with X7R or X5R temperature characteristic are strongly recommended for use here. The flying capacitors  $C_1$  and  $C_2$  should be identical. As a general rule, the capacitance value of each flying capacitor should be 1/10th that of the output capacitor. Polarized capacitor (tantalum, aluminum electrolytic, etc.) must not be used for the flying capacitors, as they could become reverse-biased upon start-up of the LM2788.

The flying capacitance determines the strength of the charge pump—the larger the capacitance, the bigger the engine. ESR in the flying capacitors negatively affects the strength of the charge pump and should be minimized, as ESR contributes to undesired output resistance. If capacitors are too small the LM2788 could spend excessive amount of time gain hopping: decreasing efficiency, increasing output voltage ripple, and possibly impeding the ability of the part to regulate. On the other hand, if the flying capacitors are too large they could potentially overwhelm the output capacitor, resulting in increased output voltage ripple.

### INPUT CAPACITOR

If the flying capacitors are the charge pump engine, the input capacitor (CIN) is the fuel tank: a reservoir of charge that aids a quick transfer of charge from the supply to the flying capacitors during the charge phase of operation. The input capacitor helps to keep the input voltage from drooping at the start of the charge phase, when the flying capacitor is first connected to the input, and helps to filter noise on the input pin that could adversely affect sensitive internal analog circuitry biased off the input line. As mentioned above, an X7R/X5R ceramic capacitor is recommended for use. As a general recommendation, the input capacitor should be chosen to match the output capacitor.

### POWER DISSIPATION

LM2788 power dissipation will, typically, not be much of a concern in most applications. Derating to accommodate self-heating will rarely be required due to the high efficiency of the part. When operating within specified operating ratings, the peak power dissipation (PD) of all LM2788 voltage options occurs with the LM2788-1.5 operating at the maximum rated operating output current of  $120\text{mA}$ . With an input voltage of  $5.5\text{V}$ , the power efficiency (E) of the LM2788-1.5 bottoms out at  $54\%$ . Assuming a typical junction-to-ambient thermal resistance ( $\theta_{JA}$ ) for the MSOP package of  $220^\circ\text{C}/\text{Watt}$ , the junction temperature ( $T_J$ ) of the part is calculated below for a part operating at the maximum rated ambient temperature ( $T_A$ ) of  $85^\circ\text{C}$ .

## Application Information (Continued)

$$\begin{aligned}
 P_D &= P_{IN} - P_{OUT} \\
 &= (P_{OUT} / E) - P_{OUT} \\
 &= [(1/E) - 1] \times P_{OUT} \\
 &= [(1/64\%) - 1] \times 1.5V \times 120mW \\
 &= 153mW
 \end{aligned}$$

$$\begin{aligned}
 T_J &= T_A + (P_D \times \theta_{JA}) \\
 &= 85^\circ\text{C} + (.153W \times 220^\circ\text{C/W}) \\
 &= 119^\circ\text{C}
 \end{aligned}$$

Even under these peak power dissipation and ambient temperature conditions, the junction temperature of the LM2788 is below the maximum operating rating of 125°C.

As an additional note, the ambient temperature operating rating range listed in the specifications is provided merely for convenience. The LM2788 may be operated outside this rating, so long as the junction temperature of the device does not exceed the maximum operating rating of 125°C.

## Layout Guidelines

Proper board layout to accommodate the LM2788 circuit will help to ensure optimal performance. The following guidelines are recommended:

- Place capacitors as close to the LM2788 as possible, and preferably on the same side of the board as the IC.

- Use short, wide traces to connect the external capacitors to the LM2788 to minimize trace resistance and inductance.
- Use a low resistance connection between ground and the GND pin of the LM2788. Using wide traces and/or multiple vias to connect GND to a ground plane on the board is most advantageous.

Figure 2 is a sample single-layer board layout that accommodates the LM2788 typical application circuit, as pictured on the cover of this datasheet

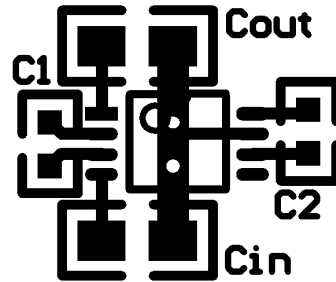

20044424

**FIGURE 2. Sample single-layer board layout of the LM2788 Typical Application Circuit (Vias to a ground plane, assumed to be present, are located in the center of the LM2788 footprint.)**

## Physical Dimensions inches (millimeters)

unless otherwise noted

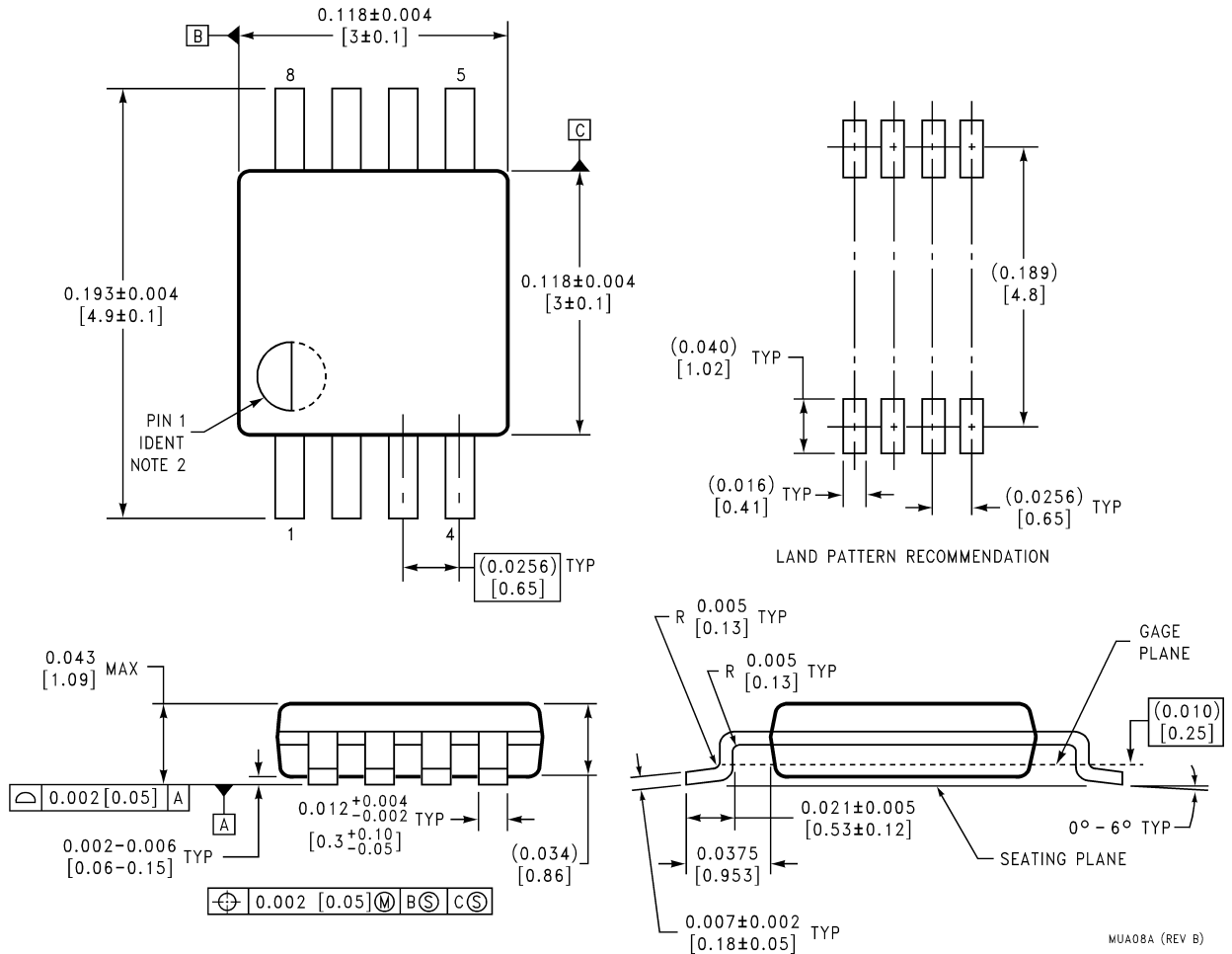

**Mini SO-8 (MSOP-8)  
MUA08A**

### LIFE SUPPORT POLICY

NATIONAL'S PRODUCTS ARE NOT AUTHORIZED FOR USE AS CRITICAL COMPONENTS IN LIFE SUPPORT DEVICES OR SYSTEMS WITHOUT THE EXPRESS WRITTEN APPROVAL OF THE PRESIDENT AND GENERAL COUNSEL OF NATIONAL SEMICONDUCTOR CORPORATION. As used herein:

1. Life support devices or systems are devices or systems which, (a) are intended for surgical implant into the body, or (b) support or sustain life, and whose failure to perform when properly used in accordance with instructions for use provided in the labeling, can be reasonably expected to result in a significant injury to the user.
2. A critical component is any component of a life support device or system whose failure to perform can be reasonably expected to cause the failure of the life support device or system, or to affect its safety or effectiveness.



**National Semiconductor**  
Americas Customer  
Support Center  
Email: new.feedback@nsc.com  
Tel: 1-800-272-9959

www.national.com

**National Semiconductor**  
Europe Customer Support Center  
Fax: +49 (0) 180-530 85 86  
Email: europe.support@nsc.com  
Deutsch Tel: +49 (0) 69 9508 6208  
English Tel: +44 (0) 870 24 0 2171  
Français Tel: +33 (0) 1 41 91 8790

**National Semiconductor**  
Asia Pacific Customer  
Support Center  
Fax: 65-6250 4466  
Email: ap.support@nsc.com  
Tel: 65-6254 4466

**National Semiconductor**  
Japan Customer Support Center  
Fax: 81-3-5639-7507  
Email: nsj.crc@jksmtp.nsc.com  
Tel: 81-3-5639-7560

[www.s-manuals.com](http://www.s-manuals.com)