



MMBT3906

PNP SILICON TRANSISTOR

GENERAL PURPOSE APPLICATION

FEATURES

- * Collector-Emitter Voltage: $V_{CE0}=40V$
- * Collector Dissipation: $P_{D(MAX)}=350mW$
- * Complementary to UTC MMBT3904

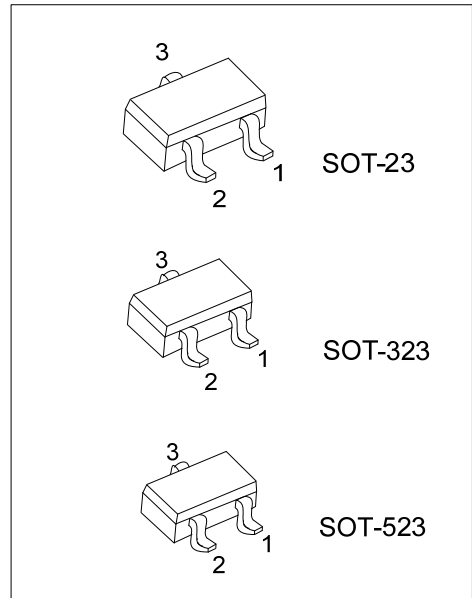

ORDERING INFORMATION

Ordering Number		Package	Pin Assignment			Packing
Lead Free	Halogen Free		1	2	3	
MMBT3906L-AE3-R	MMBT3906G-AE3-R	SOT-23	E	B	C	Tape Reel
MMBT3906L-AL3-R	MMBT3906G-AL3-R	SOT-323	E	B	C	Tape Reel
MMBT3906L-AN3-R	MMBT3906G-AN3-R	SOT-523	E	B	C	Tape Reel

<p>MMBT3906L-AE3-R</p> <p>(1) Packing Type (2) Package Type (3) Lead Plating</p>	<p>(1) R: Tape Reel (2) AE3: SOT-23, AL3: SOT-323, AN3: SOT-523 (3) G: Halogen Free, L: Lead Free</p>
--	---

MARKING

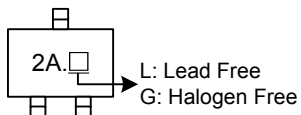

■ ABSOLUTE MAXIMUM RATING ($T_A=25^\circ\text{C}$, unless otherwise specified)

PARAMETER	SYMBOL	RATINGS	UNIT
Collector Base Voltage	V_{CBO}	-40	V
Collector Emitter Voltage	V_{CEO}	-40	V
Emitter Base Voltage	V_{EBO}	-5	V
Collector Current	I_C	-200	mA
Base Current	I_B	-50	mA
Collector Dissipation	P_C	350	mW
Junction Temperature	T_J	150	$^\circ\text{C}$
Storage Temperature	T_{STG}	-55 ~ +150	$^\circ\text{C}$

Note: Absolute maximum ratings are those values beyond which the device could be permanently damaged.

Absolute maximum ratings are stress ratings only and functional device operation is not implied.

■ ELECTRICAL CHARACTERISTICS ($T_A=25^\circ\text{C}$, unless otherwise specified)

PARAMETER	SYMBOL	TEST CONDITIONS	MIN	TYP	MAX	UNIT
Collector Cut-off Current	I_{CEX}	$V_{CE}=-30\text{V}, V_{EB}=-3\text{V}$			-50	nA
Base Cut-off Current	I_{BL}	$V_{CE}=-30\text{V}, V_{EB}=-3\text{V}$			-50	nA
Collector-Base Breakdown Voltage	V_{CBO}	$I_C=-10\mu\text{A}, I_E=0$	-40			V
Collector-Emitter Breakdown Voltage (Note)	V_{CEO}	$I_C=-1\text{mA}, I_B=0$	-40			V
Emitter-Base Breakdown Voltage	V_{EBO}	$I_E=-10\mu\text{A}, I_C=0$	-5			V
DC Current Gain (Note)	h_{FE1}	$V_{CE}=-1\text{V}, I_C=-0.1\text{mA}$	60			
	h_{FE2}	$V_{CE}=-1\text{V}, I_C=-1\text{mA}$	80			
	h_{FE3}	$V_{CE}=-1\text{V}, I_C=-10\text{mA}$	100		300	
	h_{FE4}	$V_{CE}=-1\text{V}, I_C=-50\text{mA}$	60			
	h_{FE5}	$V_{CE}=-1\text{V}, I_C=-100\text{mA}$	30			
Collector-Emitter Saturation Voltage (Note)	$V_{CE(SAT)1}$	$I_C=-10\text{mA}, I_B=-1\text{mA}$			-0.25	V
	$V_{CE(SAT)2}$	$I_C=-50\text{mA}, I_B=-5\text{mA}$			-0.4	V
Base-Emitter Saturation Voltage	$V_{BE(SAT)1}$	$I_C=-10\text{mA}, I_B=-1\text{mA}$	-0.65		-0.85	V
	$V_{BE(SAT)2}$	$I_C=-50\text{mA}, I_B=-5\text{mA}$			-0.95	V
Transition Voltage	f_T	$V_{CE}=-20\text{V}, I_C=-10\text{mA}, f=100\text{MHz}$	250			MHz
Output Capacitance	C_{ob}	$V_{CB}=-5\text{V}, I_E=0, f=1\text{MHz}$			4.5	pF
Turn on Time	t_{ON}	$V_{CC}=-3\text{V}, V_{BE}=-0.5\text{V}, I_C=-10\text{mA}, I_{B1}=-1\text{mA}$			70	ns
Turn off Time	t_{OFF}	$I_{B1}=1\text{mA}, I_{B2}=-1\text{mA}$			300	ns

Note: Pulse test: $PW \leq 300\mu\text{s}$, Duty Cycle $\leq 2\%$

TYPICAL CHARACTERISTICS

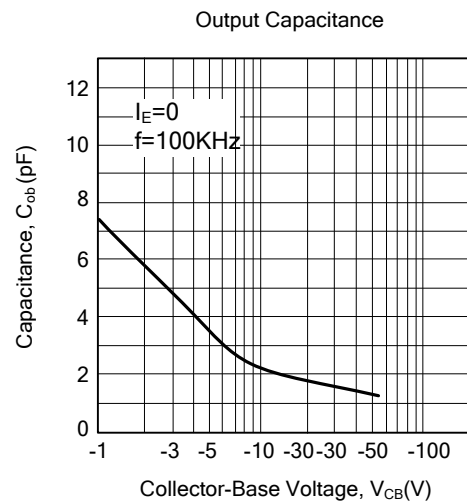
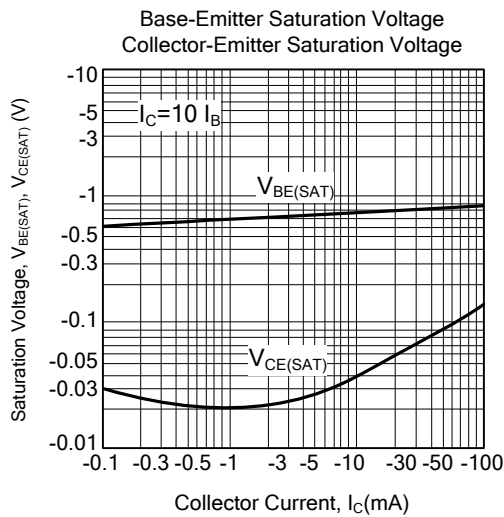
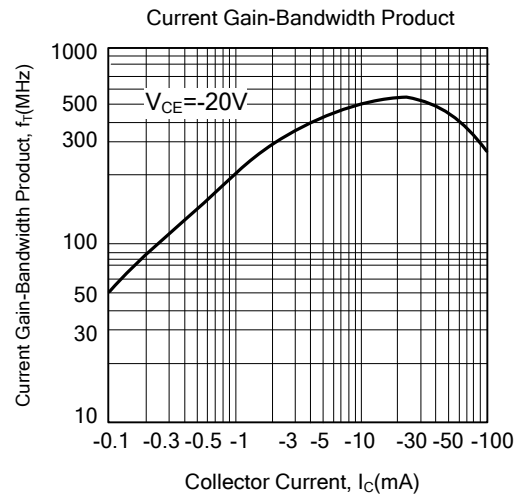
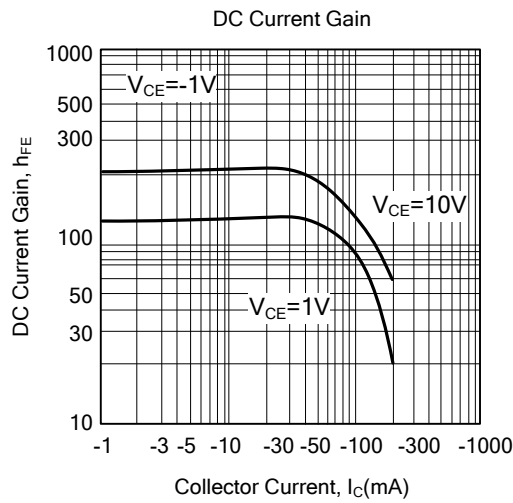

UTC assumes no responsibility for equipment failures that result from using products at values that exceed, even momentarily, rated values (such as maximum ratings, operating condition ranges, or other parameters) listed in products specifications of any and all UTC products described or contained herein. UTC products are not designed for use in life support appliances, devices or systems where malfunction of these products can be reasonably expected to result in personal injury. Reproduction in whole or in part is prohibited without the prior written consent of the copyright owner. The information presented in this document does not form part of any quotation or contract, is believed to be accurate and reliable and may be changed without notice.

www.s-manuals.com