



SOT-23 Plastic-Encapsulate Transistors

MMBTA44 TRANSISTOR (NPN)

FEATURES

- High Collector-Emitter Voltage
- Complement to MMBTA94

MARKING: 3D

MAXIMUM RATINGS (T_a=25°C unless otherwise noted)

Symbol	Parameter	Value	Unit
V _{CB0}	Collector-Base Voltage	500	V
V _{CEO}	Collector-Emitter Voltage	400	V
V _{EBO}	Emitter-Base Voltage	6	V
I _C	Collector Current	100	mA
P _C	Collector Power Dissipation	350	mW
R _{θJA}	Thermal Resistance From Junction To Ambient	357	°C/W
T _j	Junction Temperature	150	°C
T _{stg}	Storage Temperature	-55~+150	°C

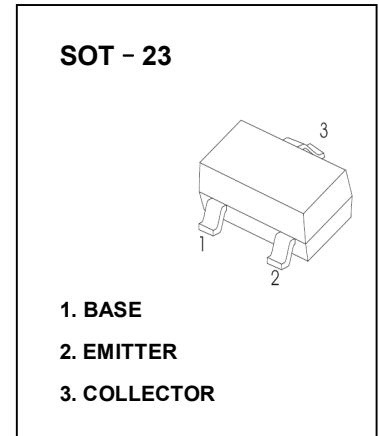

ELECTRICAL CHARACTERISTICS (T_a=25°C unless otherwise specified)

Parameter	Symbol	Test conditions	Min	Typ	Max	Unit
Collector-base breakdown voltage	V _{(BR)CBO}	I _C =100μA, I _E =0	500			V
Collector-emitter breakdown voltage	V _{(BR)CEO} *	I _C =1mA, I _B =0	400			V
Emitter-base breakdown voltage	V _{(BR)EBO}	I _E =10μA, I _C =0	6			V
Collector cut-off current	I _{CBO}	V _{CB} =400V, I _E =0			0.1	μA
Emitter cut-off current	I _{EBO}	V _{EB} =4V, I _C =0			0.1	μA
DC current gain	h _{FE(1)} *	V _{CE} =10V, I _C =1mA	40			
	h _{FE(2)} *	V _{CE} =10V, I _C =10mA	50		200	
	h _{FE(3)} *	V _{CE} =10V, I _C =50mA	45			
	h _{FE(4)} *	V _{CE} =10V, I _C =100mA	40			
Collector-emitter saturation voltage	V _{CE(sat)1} *	I _C =1mA, I _B =0.1mA			0.4	V
	V _{CE(sat)2} *	I _C =10mA, I _B =1mA			0.5	V
	V _{CE(sat)3} *	I _C =50mA, I _B =5mA			0.75	V
Base-emitter saturation voltage	V _{BE(sat)} *	I _C =10mA, I _B =1mA			0.75	V
Collector output capacitance	C _{ob}	V _{CB} =20V, I _E =0, f=1MHz			7	pF
Emitter input capacitance	C _{ib}	V _{EB} =0.5V, I _C =0, f=1MHz			130	pF

*Pulse test: pulse width ≤300μs, duty cycles ≤ 2.0%.

www.s-manuals.com