LOW NOISE 150mA LDO REGULATOR

NO.EA-173-131031

OUTLINE

The RP130x Series are CMOS-based positive voltage regulator ICs with high ripple rejection, low dropout voltage, high output voltage accuracy and extremely low supply current. Each of these ICs consists of a voltage reference unit, an error amplifier, a resistor-net for voltage setting, a short current limit circuit and a chip enable circuit.

These ICs have an excellent low supply current performed by CMOS process, moreover they perform with low dropout voltage due to built-in low ON-resistance. A chip enable function prolongs the battery life.

The input transient response, the load transient response and the ripple rejection have been improved in the RP130x Series compared with the conventional products. Besides achieving low supply current (Typ.38 μ A).

The range of the operation voltage is capable from 1.7V to 6.5V and the range of the output voltage is capable from 1.2V to 5.3V for this product, which is wider range as our conventional product R1114x series.

The output voltage of these ICs is fixed with high accuracy. Since the packages for these ICs are DFN(PLP)1010-4, SOT-23-5 and SC-82AB, therefore high density mounting of the ICs on boards is possible.

FEATURES

- Supply Current Typ. 38 μ A
- Supply Current (Standby Mode) Typ. 0.1 μ A
- Ripple Rejection..... Typ. 80dB (f=1kHz)
- Input Voltage Range 1.7V to 6.5V
- Output Voltage Range 1.2V to 5.3V (0.1V steps)
(For other voltages, please refer to MARK INFORMATIONS.)
- Output Voltage Accuracy $\pm 1.0\%$ ($V_{OUT}>2.0V$, $T_{opt}=25^{\circ}C$)
- Temperature-Drift Coefficient of Output Voltage Typ. $\pm 20ppm/^{\circ}C$
- Dropout Voltage Typ. 0.32V ($I_{OUT}=150mA$, $V_{OUT}=2.8V$)
- Line Regulation Typ. 0.02%/V
- Packages DFN(PLP)1010-4, SC-82AB, SOT-23-5
- Built-in Fold Back Protection Circuit Typ. 40mA
- Ceramic capacitors are recommended to be used with this IC0.47 μ F or more

APPLICATIONS

- Power source for battery-powered equipment.
- Power source for portable communication equipment.
- Power source for electrical appliances such as cameras, VCRs and camcorders.
- Power source for high stable reference voltage.

BLOCK DIAGRAMS

RP130xxx1A

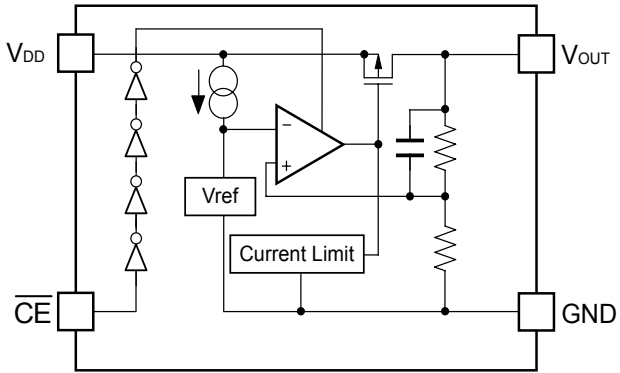

RP130xxx1B

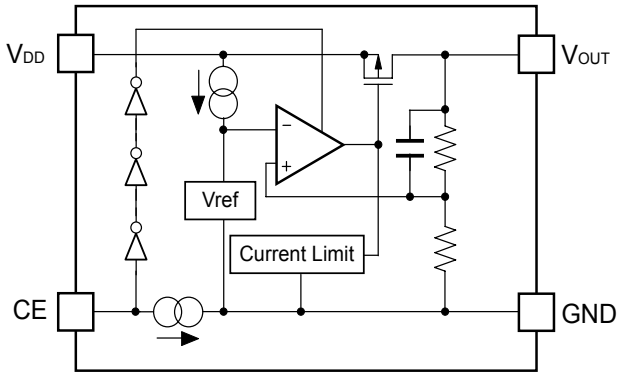

RP130xxx1D

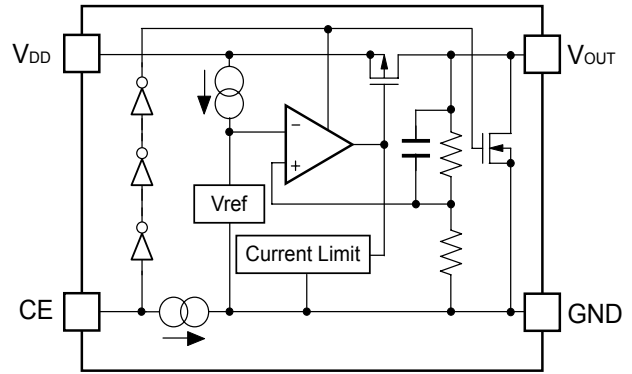

SELECTION GUIDE

The output voltage, chip enable polarity, auto discharge function, and package, etc. for the ICs can be selected at the user's request.

Product Name	Package	Quantity per Reel	Pb Free	Halogen Free
RP130Kxx1*-TR	DFN(PLP)1010-4	10,000 pcs	Yes	Yes
RP130Qxx1*-TR-FE	SC-82AB	3,000 pcs	Yes	Yes
RP130Nxx1*-TR-FE	SOT-23-5	3,000 pcs	Yes	Yes

xx : Set Output Voltage (V_{SET})

Fixed Type: 12 to 53 Stepwise setting with 0.1V increment in the range from 1.2V to 5.3V

Exception: 1.25V=RP130x121*5-TR

1.85V=RP130x181*5-TR

2.85V=RP130x281*5-TR

* : CE pin polarity and auto discharge function at off state are options as follows.

A: active low, without auto discharge function at off state.

B: active high, without auto discharge function at off state.

D: active high, with auto discharge function at off state.

PIN CONFIGURATIONS

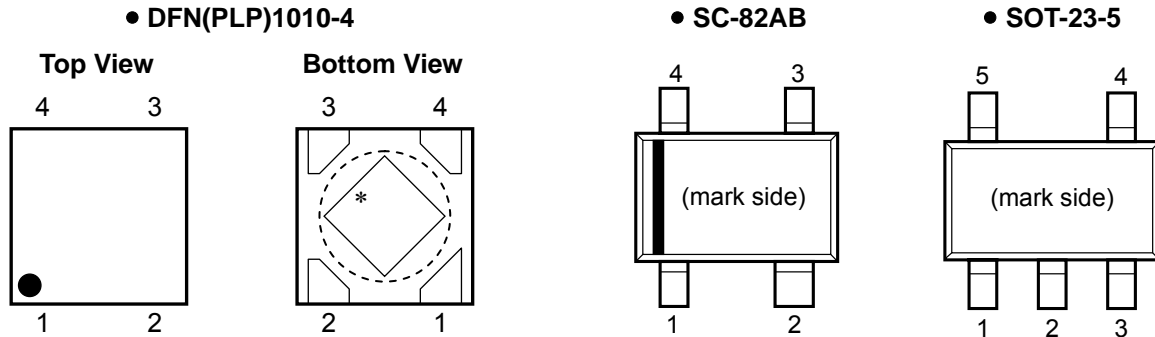

PIN DESCRIPTIONS

• DFN(PLP)1010-4

Pin No	Symbol	Pin Description
1	V_{OUT}	Output Pin
2	GND	Ground Pin
3	\overline{CE} / CE	Chip Enable Pin ("L" Active / "H" Active)
4	V_{DD}	Input Pin

*) Tab is GND level. (They are connected to the reverse side of this IC.)

The tab is better to be connected to the GND, but leaving it open is also acceptable.

• SC-82AB

Pin No	Symbol	Pin Description
1	\overline{CE} / CE	Chip Enable Pin ("L" Active / "H" Active)
2	GND	Ground Pin
3	V_{OUT}	Output Pin
4	V_{DD}	Input Pin

• SOT-23-5

Pin No	Symbol	Pin Description
1	V_{DD}	Input Pin
2	GND	Ground Pin
3	\overline{CE} / CE	Chip Enable Pin ("L" Active / "H" Active)
4	NC	No Connection
5	V_{OUT}	Output Pin

ABSOLUTE MAXIMUM RATINGS

Symbol	Item	Rating	Unit
V_{IN}	Input Voltage	7.0	V
V_{CE}	Input Voltage (CE Pin)	-0.3 to 7.0	V
V_{OUT}	Output Voltage	-0.3 to $V_{IN}+0.3$	V
I_{OUT}	Output Current	200	mA
P_D	Power Dissipation (DFN(PLP)1010-4)*	400	mW
	Power Dissipation (SC-82AB)*	380	
	Power Dissipation (SOT-23-5)*	420	
T_{opt}	Operating Temperature Range	-40 to 85	°C
T_{stg}	Storage Temperature Range	-55 to 125	°C

*) For Power Dissipation, please refer to PACKAGE INFORMATION.

ABSOLUTE MAXIMUM RATINGS

Electronic and mechanical stress momentarily exceeded absolute maximum ratings may cause the permanent damages and may degrade the life time and safety for both device and system using the device in the field.

The functional operation at or over these absolute maximum ratings is not assured.

RP130x

NO.EA-173-131031

ELECTRICAL CHARACTERISTICS

$V_{IN}=V_{SET}+1V$ ($V_{OUT}>1.5V$), $V_{IN}=2.5V$ ($V_{OUT}\leq 1.5V$), $I_{OUT}=1mA$, $C_{IN}=C_{OUT}=0.47\mu F$, unless otherwise noted.

The specifications surrounded by are guaranteed by Design Engineering at $-40^{\circ}C \leq Ta \leq 85^{\circ}C$.

● RP130xxx1A

($Ta=25^{\circ}C$)

Symbol	Item	Conditions	Min.	Typ.	Max.	Unit	
V_{OUT}	Output Voltage	$Ta=25^{\circ}C$	$V_{SET} > 2.0V$	x 0.99		x 1.01	V
			$V_{SET} \leq 2.0V$	-20		+20	mV
		$-40^{\circ}C \leq Ta \leq 85^{\circ}C$	$V_{SET} > 2.0V$	x 0.985		x 1.015	V
			$V_{SET} \leq 2.0V$	-30		+30	mV
I_{LIM}	Output Current Limit		150			mA	
$\frac{\Delta V_{OUT}}{\Delta I_{OUT}}$	Load Regulation	$1mA \leq I_{OUT} \leq 150mA$		10	30	mV	
V_{DIF}	Dropout Voltage	Please see the table (Dropout Voltage) on below page.					
I_{SS}	Supply Current	$I_{OUT}=0mA$		38	58	μA	
Istandby	Supply Current (Standby)	$V_{CE}=V_{IN}$		0.1	1.0	μA	
$\frac{\Delta V_{OUT}}{\Delta V_{IN}}$	Line Regulation	$V_{SET}+0.5V \leq V_{IN} \leq 6.5V$		0.02	0.10	%/V	
RR	Ripple Rejection	$f=1kHz$, Ripple 0.2Vp-p $V_{IN}=V_{SET}+1V$ $I_{OUT}=30mA$ (In case that $V_{OUT} \leq 2.0V$, $V_{IN}=3.0V$)		80		dB	
V_{IN}	Input Voltage		1.7		6.5	V	
$\frac{\Delta V_{OUT}}{\Delta Ta}$	Output Voltage Temperature Coefficient	$-40^{\circ}C \leq Ta \leq 85^{\circ}C$		± 20		ppm/ $^{\circ}C$	
I_{SC}	Short Current Limit	$V_{OUT}=0V$		40		mA	
V_{CEH}	\overline{CE} Input Voltage "H"		1.0			μA	
V_{CEL}	\overline{CE} Input Voltage "L"				0.4		
en	Output Noise	$BW=10Hz$ to $100kHz$ $I_{OUT}=30mA$		20 $\times V_{SET}$		μV_{rms}	

All test items listed under *Electrical Characteristics* are done under the pulse load condition ($Tj \approx Ta=25^{\circ}C$) except for Output Noise, Ripple Rejection, and Output Voltage Temperature Coefficient.

$V_{IN}=V_{SET}+1V$ ($V_{OUT}>1.5V$), $V_{IN}=2.5V$ ($V_{OUT} \leq 1.5V$), $I_{OUT}=1mA$, $C_{IN}=C_{OUT}=0.47\mu F$, unless otherwise noted.

The specifications surrounded by are guaranteed by Design Engineering at $-40^{\circ}C \leq Ta \leq 85^{\circ}C$.

● RP130xxx1B/D

($Ta=25^{\circ}C$)

Symbol	Item	Conditions	Min.	Typ.	Max.	Unit	
V_{OUT}	Output Voltage	$Ta=25^{\circ}C$	$V_{SET} > 2.0V$	x 0.99		x 1.01	V
			$V_{SET} \leq 2.0V$	-20		+20	mV
		$-40^{\circ}C \leq Ta \leq 85^{\circ}C$	$V_{SET} > 2.0V$	x 0.985		x 1.015	V
			$V_{SET} \leq 2.0V$	-30		+30	mV
I_{LIM}	Output Current Limit		150			mA	
$\frac{\Delta V_{OUT}}{\Delta I_{OUT}}$	Load Regulation	$1mA \leq I_{OUT} \leq 150mA$		10	30	mV	
V_{DIF}	Dropout Voltage	Please see the table (Dropout Voltage) on next page.					
I_{SS}	Supply Current	$I_{OUT}=0mA$		38	58	μA	
Istandby	Supply Current (Standby)	$V_{CE}=V_{IN}$		0.1	1.0	μA	
$\frac{\Delta V_{OUT}}{\Delta V_{IN}}$	Line Regulation	$V_{SET}+0.5V \leq V_{IN} \leq 6.5V$		0.02	0.10	%/V	
RR	Ripple Rejection	f=1kHz, Ripple 0.2Vp-p $V_{IN}=V_{SET}+1V$ $I_{OUT}=30mA$ (In case that $V_{OUT} \leq 2.0V$, $V_{IN}=3.0V$)		80		dB	
V_{IN}	Input Voltage		1.7		6.5	V	
$\frac{\Delta V_{OUT}}{\Delta Ta}$	Output Voltage Temperature Coefficient	$-40^{\circ}C \leq Ta \leq 85^{\circ}C$		± 20		ppm/ $^{\circ}C$	
I_{SC}	Short Current Limit	$V_{OUT}=0V$		40		mA	
I_{PD}	CE Pull-down Current			0.4		μA	
V_{CEH}	\overline{CE} Input Voltage "H"		1.0			μA	
V_{CEL}	\overline{CE} Input Voltage "L"				0.4		
en	Output Noise	BW=10Hz to 100kHz $I_{OUT}=30mA$		20 $\times V_{SET}$		μV_{rms}	
R_{LOW}	Nch ON Resistance for Auto Discharge (D version Only)	$V_{IN}=4.0V$ $V_{CE}=0V$		30		Ω	

All test items listed under *Electrical Characteristics* are done under the pulse load condition ($T_J \approx Ta=25^{\circ}C$) except for Output Noise, Ripple Rejection, and Output Voltage Temperature Coefficient.

RP130x

NO.EA-173-131031

The specifications surrounded by are guaranteed by Design Engineering at $-40^{\circ}\text{C} \leq T_a \leq 85^{\circ}\text{C}$.

Dropout Voltage

(Ta=25°C)

Output Voltage V_{OUT} (V)	Dropout Voltage V_{DIF} (V)		
	Condition	TYP.	MAX.
$1.2\text{V} \leq V_{\text{SET}} < 1.5\text{V}$	$I_{\text{OUT}} = 150\text{mA}$	0.67	1.00
$1.5\text{V} \leq V_{\text{SET}} < 1.7\text{V}$		0.54	0.81
$1.7\text{V} \leq V_{\text{SET}} < 2.0\text{V}$		0.46	0.68
$2.0\text{V} \leq V_{\text{SET}} < 2.5\text{V}$		0.41	0.60
$2.5\text{V} \leq V_{\text{SET}} < 4.0\text{V}$		0.32	0.51
$4.0\text{V} \leq V_{\text{SET}}$		0.24	0.37

RECOMMENDED OPERATING CONDITIONS (ELECTRICAL CHARACTERISTICS)

All of electronic equipment should be designed that the mounted semiconductor devices operate within the recommended operating conditions. The semiconductor devices cannot operate normally over the recommended operating conditions, even if when they are used over such conditions by momentary electronic noise or surge. And the semiconductor devices may receive serious damage when they continue to operate over the recommended operating conditions.

TYPICAL APPLICATION

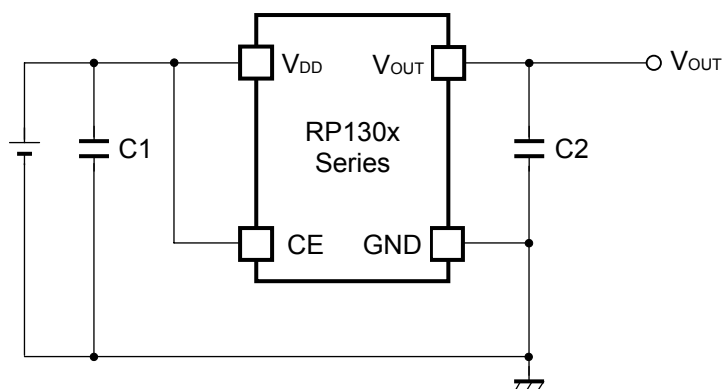

(External Components)

Ceramic Capacitor C2 0.47 μ F MURATA GRM155B30J474KE18B

TECHNICAL NOTES

When using these ICs, consider the following points:

Phase Compensation

In these ICs, phase compensation is made for securing stable operation even if the load current is varied. For this purpose, use a capacitor C2 with 0.47 μ F or more.

If a tantalum capacitor is used, and its ESR (Equivalent Series Resistance) of C2 is large, the loop oscillation may result. Because of this, select C2 carefully considering its frequency characteristics.

PCB Layout

Make V_{DD} and GND lines sufficient. If their impedance is high, noise pickup or unstable operation may result. Connect a capacitor C1 with a capacitance value as much as 0.47 μ F or more between V_{DD} and GND pin, and as close as possible to the pins.

Set external components, especially the output capacitor C2, as close as possible to the ICs, and make wiring as short as possible.

PACKAGE INFORMATION

- Power Dissipation (DFN(PLP)1010-4)

Power Dissipation (P_D) depends on conditions of mounting on board. This specification is based on the measurement at the condition below:

Measurement Conditions

	Standard Test Land Pattern
Environment	Mounting on Board (Wind velocity=0m/s)
Board Material	Glass cloth epoxy plastic (Double sided)
Board Dimensions	40mm x 40mm x 1.6mm
Copper Ratio	Top side: Approx. 50%, Back side: Approx. 50%
Through-holes	ϕ 0.54mm x 24pcs

Measurement Result

($T_a=25^\circ\text{C}$, $T_{j\text{max}}=125^\circ\text{C}$)

	Standard Test Land Pattern
Power Dissipation	400mW($T_{j\text{max}}=125^\circ\text{C}$) 500mW($T_{j\text{max}}=150^\circ\text{C}$)
Thermal Resistance	$\theta_{ja} = (125-25^\circ\text{C})/0.4\text{W} = 250^\circ\text{C/W}$ $\theta_{jc}=67^\circ\text{C/W}$

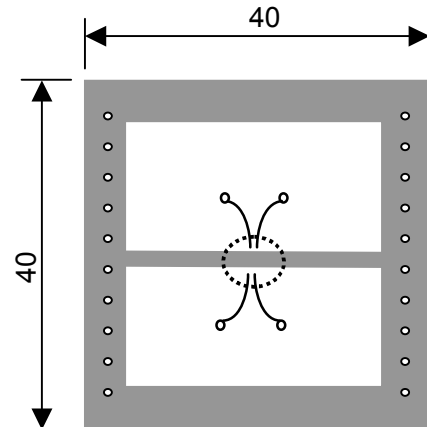
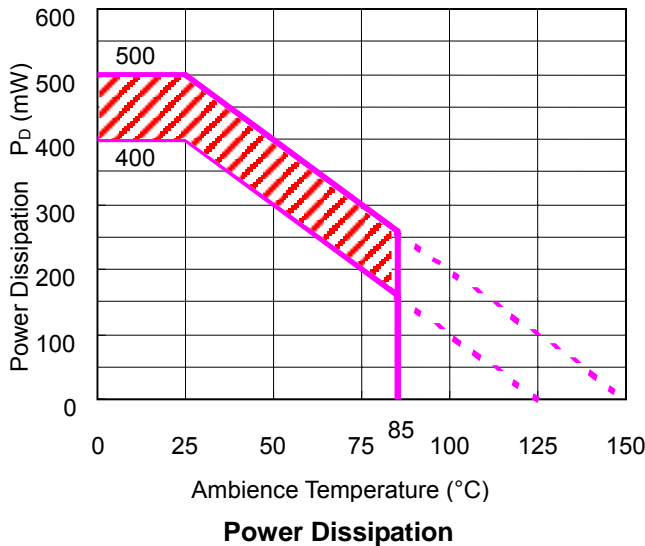

Measurement Board Pattern
○ IC Mount Area (Unit:mm)

The above graph shows the Power Dissipation of the package based on $T_{j\text{max}}=125^\circ\text{C}$ and $T_{j\text{max}}=150^\circ\text{C}$. Operating the IC in the shaded area in the graph might have an influence its lifetime.

Operating time must be within the time limit described in the table below, in case of operating in the shaded area.

Operating Time	Estimated years (Operating four hours/day)
13,000 hours	9years

● Package Dimensions (DFN(PLP)1010-4)

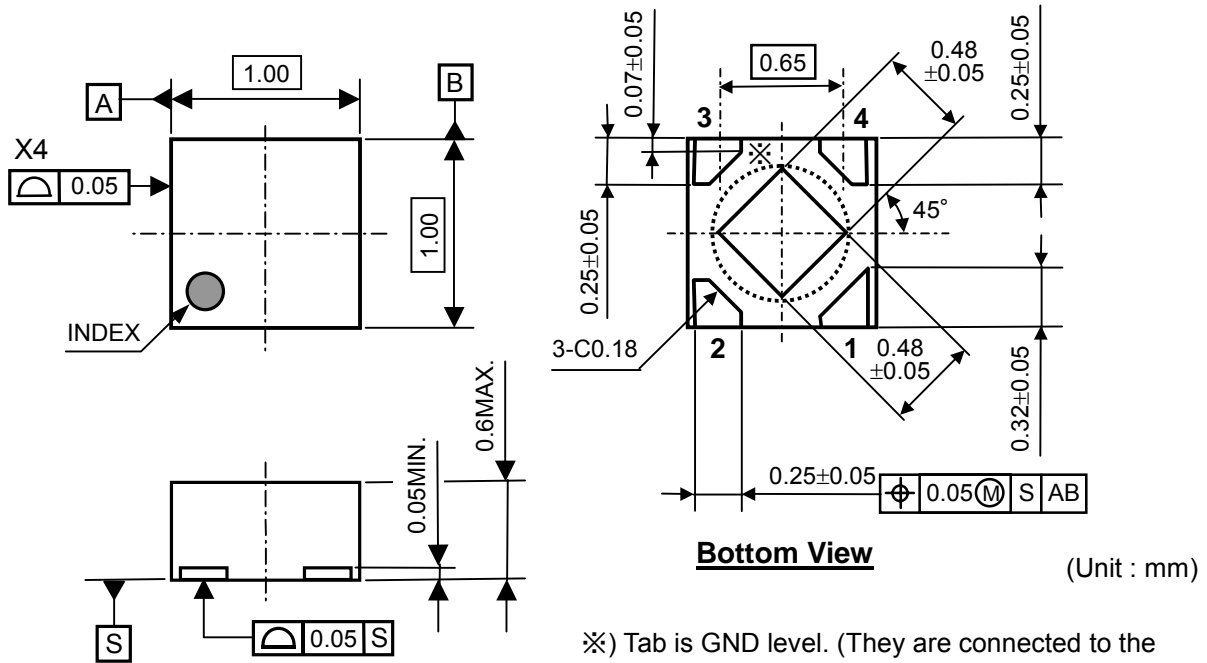

※) Tab is GND level. (They are connected to the reverse side of this IC.)
 The tab is better to be connected to the GND, but leaving it open is also acceptable.

● Mark Specifications (DFN(PLP)1010-4)

- ①②: Product Code ... **Please refer to RP130K Series Mark Specification Table**
- ③④: Lot Number ... Alphanumeric Serial Number

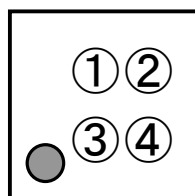

RP130x

NO.EA-173-131031

● RP130K Series Mark Specification Table (DFN(PLP)1010-4)

RP130Kxx1A

Part Number	①②	V _{SET}
RP130K121A	RA	1.2V
RP130K131A	RB	1.3V
RP130K141A	RC	1.4V
RP130K151A	RD	1.5V
RP130K161A	RE	1.6V
RP130K171A	RF	1.7V
RP130K181A	RG	1.8V
RP130K191A	RJ	1.9V
RP130K201A	RK	2.0V
RP130K211A	RL	2.1V
RP130K221A	RM	2.2V
RP130K231A	RN	2.3V
RP130K241A	RP	2.4V
RP130K251A	RQ	2.5V
RP130K261A	RR	2.6V
RP130K271A	RS	2.7V
RP130K281A	RT	2.8V
RP130K291A	RV	2.9V
RP130K301A	RW	3.0V
RP130K311A	RX	3.1V
RP130K321A	RY	3.2V
RP130K331A	RZ	3.3V
RP130K341A	SA	3.4V
RP130K351A	SB	3.5V
RP130K361A	SC	3.6V
RP130K371A	SD	3.7V
RP130K381A	SE	3.8V
RP130K391A	SF	3.9V
RP130K401A	SG	4.0V
RP130K411A	SH	4.1V
RP130K421A	SJ	4.2V
RP130K431A	SK	4.3V
RP130K441A	SL	4.4V
RP130K451A	SM	4.5V
RP130K461A	SN	4.6V
RP130K471A	SP	4.7V
RP130K481A	SQ	4.8V
RP130K491A	SR	4.9V
RP130K501A	SS	5.0V
RP131K511A	SV	5.1V
RP131K521A	SW	5.2V
RP131K531A	SX	5.3V
RP131K121A5	SU	1.25V
RP130K181A5	RH	1.85V
RP130K281A5	RU	2.85V

RP130Kxx1B

Part Number	①②	V _{SET}
RP130K121B	TA	1.2V
RP130K131B	TB	1.3V
RP130K141B	TC	1.4V
RP130K151B	TD	1.5V
RP130K161B	TE	1.6V
RP130K171B	TF	1.7V
RP130K181B	TG	1.8V
RP130K191B	TJ	1.9V
RP130K201B	TK	2.0V
RP130K211B	TL	2.1V
RP130K221B	TM	2.2V
RP130K231B	TN	2.3V
RP130K241B	TP	2.4V
RP130K251B	TQ	2.5V
RP130K261B	TR	2.6V
RP130K271B	TS	2.7V
RP130K281B	TT	2.8V
RP130K291B	TV	2.9V
RP130K301B	TW	3.0V
RP130K311B	TX	3.1V
RP130K321B	TY	3.2V
RP130K331B	TZ	3.3V
RP130K341B	UA	3.4V
RP130K351B	UB	3.5V
RP130K361B	UC	3.6V
RP130K371B	UD	3.7V
RP130K381B	UE	3.8V
RP130K391B	UF	3.9V
RP130K401B	UG	4.0V
RP130K411B	UH	4.1V
RP130K421B	UJ	4.2V
RP130K431B	UK	4.3V
RP130K441B	UL	4.4V
RP130K451B	UM	4.5V
RP130K461B	UN	4.6V
RP130K471B	UP	4.7V
RP130K481B	UQ	4.8V
RP130K491B	UR	4.9V
RP130K501B	US	5.0V
RP131K511B	UV	5.1V
RP131K521B	UW	5.2V
RP131K531B	UX	5.3V
RP131K121B5	UU	1.25V
RP130K181B5	TH	1.85V
RP130K281B5	TU	2.85V

RP130Kxx1D

Part Number	①②	V _{SET}
RP130K121D	VA	1.2V
RP130K131D	VB	1.3V
RP130K141D	VC	1.4V
RP130K151D	VD	1.5V
RP130K161D	VE	1.6V
RP130K171D	VF	1.7V
RP130K181D	VG	1.8V
RP130K191D	VJ	1.9V
RP130K201D	VK	2.0V
RP130K211D	VL	2.1V
RP130K221D	VM	2.2V
RP130K231D	VN	2.3V
RP130K241D	VP	2.4V
RP130K251D	VQ	2.5V
RP130K261D	VR	2.6V
RP130K271D	VS	2.7V
RP130K281D	VT	2.8V
RP130K291D	VV	2.9V
RP130K301D	VW	3.0V
RP130K311D	VX	3.1V
RP130K321D	VY	3.2V
RP130K331D	VZ	3.3V
RP130K341D	WA	3.4V
RP130K351D	WB	3.5V
RP130K361D	WC	3.6V
RP130K371D	WD	3.7V
RP130K381D	WE	3.8V
RP130K391D	WF	3.9V
RP130K401D	WG	4.0V
RP130K411D	WH	4.1V
RP130K421D	WJ	4.2V
RP130K431D	WK	4.3V
RP130K441D	WL	4.4V
RP130K451D	WM	4.5V
RP130K461D	WN	4.6V
RP130K471D	WP	4.7V
RP130K481D	WQ	4.8V
RP130K491D	WR	4.9V
RP130K501D	WS	5.0V
RP131K511D	WV	5.1V
RP131K521D	WW	5.2V
RP131K531D	WX	5.3V
RP131K121D5	WU	1.25V
RP130K181D5	VH	1.85V
RP130K281D5	VU	2.85V

• **Power Dissipation (SC-82AB)**

Power Dissipation (P_D) depends on conditions of mounting on board. This specification is based on the measurement at the condition below:

Measurement Conditions

	Standard Land Pattern
Environment	Mounting on Board (Wind velocity=0m/s)
Board Material	Glass cloth epoxy plastic (Double Layers)
Board Dimensions	40mm x 40mm x 1.6mm
Copper Ratio	Top side: Approx. 50%, Back side: Approx. 50%
Through-hole	ϕ 0.5mm x 44pcs

Measurement Result

($T_a=25^\circ\text{C}$)

	Standard Land Pattern	Free Air
Power Dissipation	380mW ($T_{jmax}=125^\circ\text{C}$) 475mW ($T_{jmax}=150^\circ\text{C}$)	150mW ($T_{jmax}=125^\circ\text{C}$)
Thermal Resistance	$\theta_{ja}=(125-25^\circ\text{C})/0.38\text{W}=263^\circ\text{C/W}$	667 $^\circ\text{C/W}$

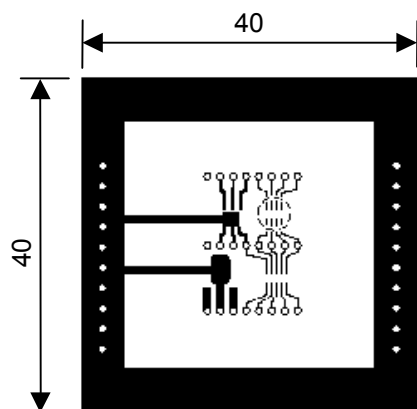
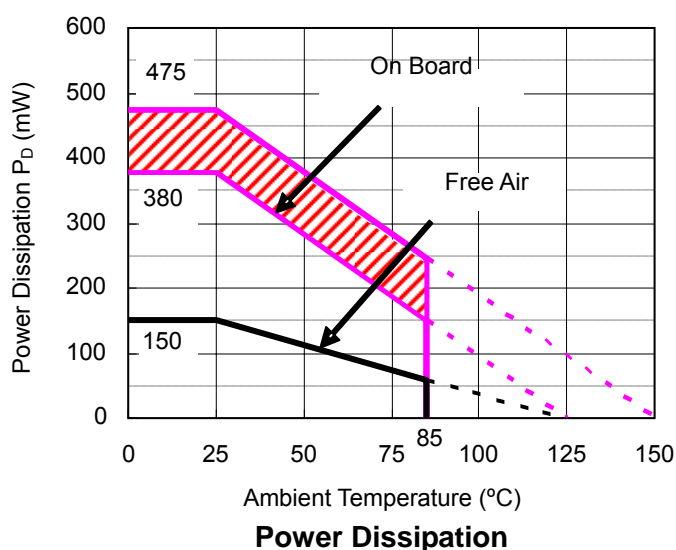

Measurement Board Pattern

○ IC Mount Area (Unit : mm)

The above graph shows the Power Dissipation of the package based on $T_{jmax}=125^\circ\text{C}$ and $T_{jmax}=150^\circ\text{C}$. Operating the IC in the shaded area in the graph might have an influence it's lifetime. Operating time must be within the time limit described in the table below, in case of operating in the shaded area.

Operating Time	Estimated years (Operating four hours/day)
13,000 hours	9years

RP130xNO.EA-173-131031

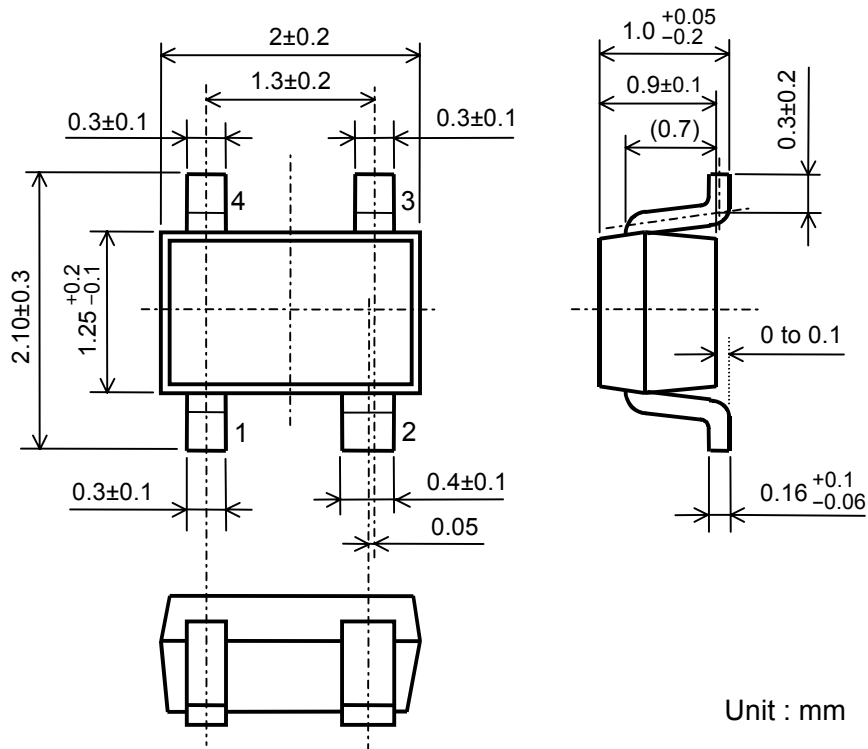
• Package Dimensions (SC-82AB)**• Mark Specifications (SC-82AB)**

- ①②: Product Code ... **Please refer to RP130Q Series Mark Specification Table**
- ③④: Lot Number ... Alphanumeric Serial Number

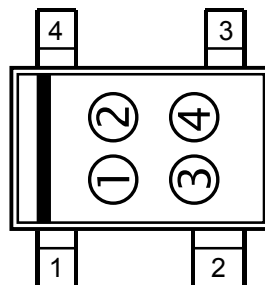

● RP130Q Series Mark Specification Table (SC-82AB)

RP130Qxx1A			RP130Qxx1B			RP130Qxx1D		
Part Number	①②	V _{SET}	Part Number	①②	V _{SET}	Part Number	①②	V _{SET}
RP130Q121A	AA	1.2V	RP130Q121B	FA	1.2V	RP130Q121D	LA	1.2V
RP130Q131A	AB	1.3V	RP130Q131B	FB	1.3V	RP130Q131D	LB	1.3V
RP130Q141A	AC	1.4V	RP130Q141B	FC	1.4V	RP130Q141D	LC	1.4V
RP130Q151A	AD	1.5V	RP130Q151B	FD	1.5V	RP130Q151D	LD	1.5V
RP130Q161A	AE	1.6V	RP130Q161B	FE	1.6V	RP130Q161D	LE	1.6V
RP130Q171A	AF	1.7V	RP130Q171B	FF	1.7V	RP130Q171D	LF	1.7V
RP130Q181A	AG	1.8V	RP130Q181B	FG	1.8V	RP130Q181D	LG	1.8V
RP130Q191A	AJ	1.9V	RP130Q191B	FJ	1.9V	RP130Q191D	LJ	1.9V
RP130Q201A	AK	2.0V	RP130Q201B	FK	2.0V	RP130Q201D	LK	2.0V
RP130Q211A	BA	2.1V	RP130Q211B	GA	2.1V	RP130Q211D	MA	2.1V
RP130Q221A	BB	2.2V	RP130Q221B	GB	2.2V	RP130Q221D	MB	2.2V
RP130Q231A	BC	2.3V	RP130Q231B	GC	2.3V	RP130Q231D	MC	2.3V
RP130Q241A	BD	2.4V	RP130Q241B	GD	2.4V	RP130Q241D	MD	2.4V
RP130Q251A	BE	2.5V	RP130Q251B	GE	2.5V	RP130Q251D	ME	2.5V
RP130Q261A	BF	2.6V	RP130Q261B	GF	2.6V	RP130Q261D	MF	2.6V
RP130Q271A	BG	2.7V	RP130Q271B	GG	2.7V	RP130Q271D	MG	2.7V
RP130Q281A	BH	2.8V	RP130Q281B	GH	2.8V	RP130Q281D	MH	2.8V
RP130Q291A	BK	2.9V	RP130Q291B	GK	2.9V	RP130Q291D	MK	2.9V
RP130Q301A	CA	3.0V	RP130Q301B	HA	3.0V	RP130Q301D	NA	3.0V
RP130Q311A	CB	3.1V	RP130Q311B	HB	3.1V	RP130Q311D	NB	3.1V
RP130Q321A	CC	3.2V	RP130Q321B	HC	3.2V	RP130Q321D	NC	3.2V
RP130Q331A	CD	3.3V	RP130Q331B	HD	3.3V	RP130Q331D	ND	3.3V
RP130Q341A	CE	3.4V	RP130Q341B	HE	3.4V	RP130Q341D	NE	3.4V
RP130Q351A	CF	3.5V	RP130Q351B	HF	3.5V	RP130Q351D	NF	3.5V
RP130Q361A	CG	3.6V	RP130Q361B	HG	3.6V	RP130Q361D	NG	3.6V
RP130Q371A	CH	3.7V	RP130Q371B	HH	3.7V	RP130Q371D	NH	3.7V
RP130Q381A	CJ	3.8V	RP130Q381B	HJ	3.8V	RP130Q381D	NJ	3.8V
RP130Q391A	CK	3.9V	RP130Q391B	HK	3.9V	RP130Q391D	NK	3.9V
RP130Q401A	DA	4.0V	RP130Q401B	JA	4.0V	RP130Q401D	PA	4.0V
RP130Q411A	DB	4.1V	RP130Q411B	JB	4.1V	RP130Q411D	PB	4.1V
RP130Q421A	DC	4.2V	RP130Q421B	JC	4.2V	RP130Q421D	PC	4.2V
RP130Q431A	DD	4.3V	RP130Q431B	JD	4.3V	RP130Q431D	PD	4.3V
RP130Q441A	DE	4.4V	RP130Q441B	JE	4.4V	RP130Q441D	PE	4.4V
RP130Q451A	DF	4.5V	RP130Q451B	JF	4.5V	RP130Q451D	PF	4.5V
RP130Q461A	DG	4.6V	RP130Q461B	JG	4.6V	RP130Q461D	PG	4.6V
RP130Q471A	DH	4.7V	RP130Q471B	JH	4.7V	RP130Q471D	PH	4.7V
RP130Q481A	DJ	4.8V	RP130Q481B	JJ	4.8V	RP130Q481D	PJ	4.8V
RP130Q491A	DK	4.9V	RP130Q491B	JK	4.9V	RP130Q491D	PK	4.9V
RP130Q501A	EA	5.0V	RP130Q501B	KA	5.0V	RP130Q501D	QA	5.0V
RP130Q511A	ED	5.1V	RP130Q511B	KD	5.1V	RP130Q511D	QD	5.1V
RP130Q521A	EE	5.2V	RP130Q521B	KE	5.2V	RP130Q521D	QE	5.2V
RP130Q531A	EF	5.3V	RP130Q531B	KF	5.3V	RP130Q531D	QF	5.3V
RP130Q121A5	EC	1.25V	RP130Q121B5	KC	1.25V	RP130Q121D5	QC	1.25V
RP130Q181A5	AH	1.85V	RP130Q181B5	FH	1.85V	RP130Q181D5	LH	1.85V
RP130Q281A5	BJ	2.85V	RP130Q281B5	GJ	2.85V	RP130Q281D5	MJ	2.85V

RP130x

NO.EA-173-131031

• Power Dissipation (SOT-23-5)

Power Dissipation (P_D) depends on conditions of mounting on board. This specification is based on the measurement at the condition below:

(Power Dissipation (SOT-23-5) is substitution of SOT-23-6.)

Measurement Conditions

	Standard Test Land Pattern
Environment	Mounting on Board (Wind velocity=0m/s)
Board Material	Glass cloth epoxy plastic (Double sided)
Board Dimensions	40mm x 40mm x 1.6mm
Copper Ratio	Top side: Approx. 50%, Back side: Approx. 50%
Through-holes	ϕ 0.5mm x 44pcs

Measurement Result

($T_a=25^\circ\text{C}$, $T_{j\text{max}}=125^\circ\text{C}$)

	Standard Land Pattern	Free Air
Power Dissipation	420mW($T_{j\text{max}}=125^\circ\text{C}$) 525mW($T_{j\text{max}}=150^\circ\text{C}$)	250mW
Thermal Resistance	$\theta_{ja} = (125-25^\circ\text{C})/0.42\text{W} = 238^\circ\text{C/W}$	400 $^\circ\text{C/W}$

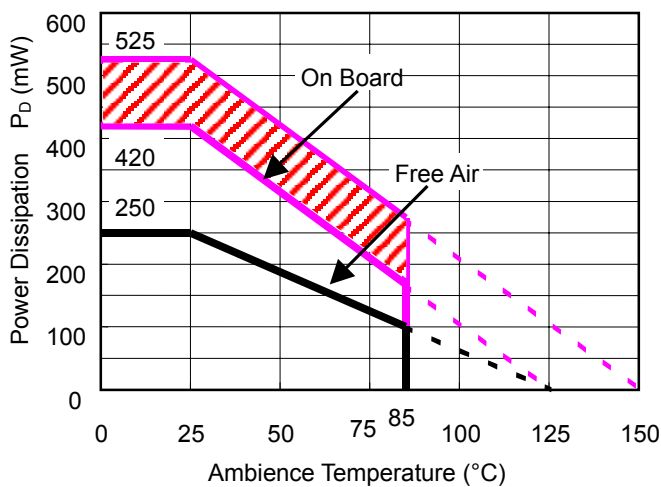

Power Dissipation

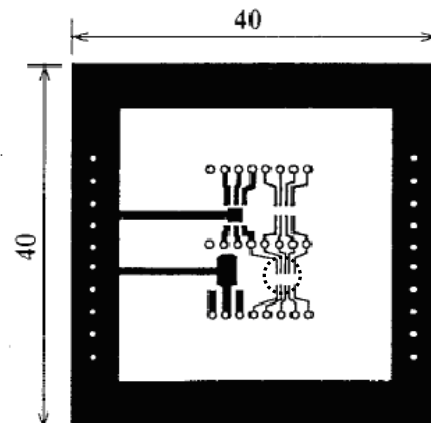

Measurement Board Pattern

○ IC Mount Area (Unit: mm)

The above graph shows the Power Dissipation of the package based on $T_{j\text{max}}=125^\circ\text{C}$ and $T_{j\text{max}}=150^\circ\text{C}$. Operating the IC in the shaded area in the graph might have an influence it's lifetime.

Operating time must be within the time limit described in the table below, in case of operating in the shaded area.

Operating Time	Estimated years (Operating four hours/day)
9,000 hours	6years

● Package Dimensions (SOT-23-5)

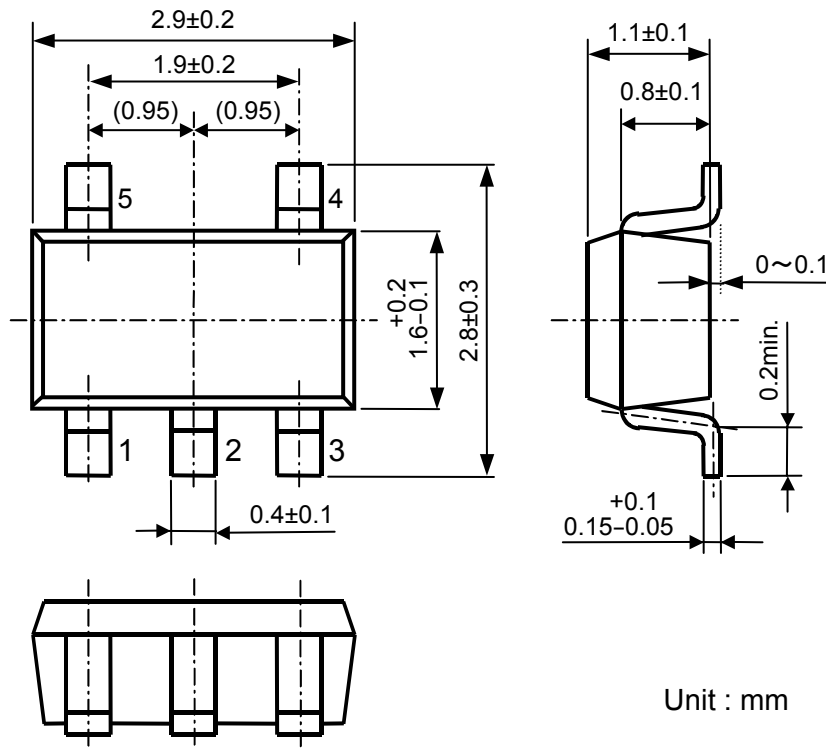

● Mark Specifications (SOT-23-5)

- ①②③: Product Code ... **Please refer to RP130N Series Mark Specification Table**
- ④⑤: Lot Number ... Alphanumeric Serial Number

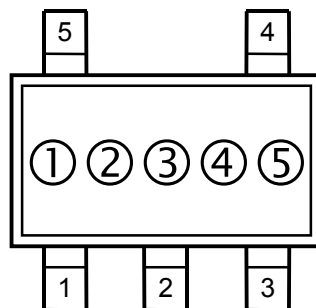

RP130x

NO.EA-173-131031

● RP130N Series Mark Specification Table (SOT-23-5)

RP130Nxx1A

Part Number	①②③	V _{SET}
RP130N121A	H0A	1.2V
RP130N131A	H0B	1.3V
RP130N141A	H0C	1.4V
RP130N151A	H0D	1.5V
RP130N161A	H0E	1.6V
RP130N171A	H0F	1.7V
RP130N181A	H0G	1.8V
RP130N191A	H0J	1.9V
RP130N201A	H0K	2.0V
RP130N211A	H0L	2.1V
RP130N221A	H0M	2.2V
RP130N231A	H0N	2.3V
RP130N241A	H0P	2.4V
RP130N251A	H0Q	2.5V
RP130N261A	H0R	2.6V
RP130N271A	H0S	2.7V
RP130N281A	H0T	2.8V
RP130N291A	H0V	2.9V
RP130N301A	H0W	3.0V
RP130N311A	H0X	3.1V
RP130N321A	H0Y	3.2V
RP130N331A	H0Z	3.3V
RP130N341A	J0A	3.4V
RP130N351A	J0B	3.5V
RP130N361A	J0C	3.6V
RP130N371A	J0D	3.7V
RP130N381A	J0E	3.8V
RP130N391A	J0F	3.9V
RP130N401A	J0G	4.0V
RP130N411A	J0H	4.1V
RP130N421A	J0J	4.2V
RP130N431A	J0K	4.3V
RP130N441A	J0L	4.4V
RP130N451A	J0M	4.5V
RP130N461A	J0N	4.6V
RP130N471A	J0P	4.7V
RP130N481A	J0Q	4.8V
RP130N491A	J0R	4.9V
RP130N501A	J0S	5.0V
RP130N511A	J0V	5.1V
RP130N521A	J0W	5.2V
RP130N531A	J0X	5.3V
RP130N121A5	J0U	1.25V
RP130N181A5	H0H	1.85V
RP130N281A5	H0U	2.85V

RP130Nxx1B

Part Number	①②③	V _{SET}
RP130N121B	H1A	1.2V
RP130N131B	H1B	1.3V
RP130N141B	H1C	1.4V
RP130N151B	H1D	1.5V
RP130N161B	H1E	1.6V
RP130N171B	H1F	1.7V
RP130N181B	H1G	1.8V
RP130N191B	H1J	1.9V
RP130N201B	H1K	2.0V
RP130N211B	H1L	2.1V
RP130N221B	H1M	2.2V
RP130N231B	H1N	2.3V
RP130N241B	H1P	2.4V
RP130N251B	H1Q	2.5V
RP130N261B	H1R	2.6V
RP130N271B	H1S	2.7V
RP130N281B	H1T	2.8V
RP130N291B	H1V	2.9V
RP130N301B	H1W	3.0V
RP130N311B	H1X	3.1V
RP130N321B	H1Y	3.2V
RP130N331B	H1Z	3.3V
RP130N341B	J1A	3.4V
RP130N351B	J1B	3.5V
RP130N361B	J1C	3.6V
RP130N371B	J1D	3.7V
RP130N381B	J1E	3.8V
RP130N391B	J1F	3.9V
RP130N401B	J1G	4.0V
RP130N411B	J1H	4.1V
RP130N421B	J1J	4.2V
RP130N431B	J1K	4.3V
RP130N441B	J1L	4.4V
RP130N451B	J1M	4.5V
RP130N461B	J1N	4.6V
RP130N471B	J1P	4.7V
RP130N481B	J1Q	4.8V
RP130N491B	J1R	4.9V
RP130N501B	J1S	5.0V
RP130N511B	J1V	5.1V
RP130N521B	J1W	5.2V
RP130N531B	J1X	5.3V
RP130N121B5	J1U	1.25V
RP130N181B5	H1H	1.85V
RP130N281B5	H1U	2.85V

RP130Nxx1D

Part Number	①②③	V _{SET}
RP130N121D	H2A	1.2V
RP130N131D	H2B	1.3V
RP130N141D	H2C	1.4V
RP130N151D	H2D	1.5V
RP130N161D	H2E	1.6V
RP130N171D	H2F	1.7V
RP130N181D	H2G	1.8V
RP130N191D	H2J	1.9V
RP130N201D	H2K	2.0V
RP130N211D	H2L	2.1V
RP130N221D	H2M	2.2V
RP130N231D	H2N	2.3V
RP130N241D	H2P	2.4V
RP130N251D	H2Q	2.5V
RP130N261D	H2R	2.6V
RP130N271D	H2S	2.7V
RP130N281D	H2T	2.8V
RP130N291D	H2V	2.9V
RP130N301D	H2W	3.0V
RP130N311D	H2X	3.1V
RP130N321D	H2Y	3.2V
RP130N331D	H2Z	3.3V
RP130N341D	J2A	3.4V
RP130N351D	J2B	3.5V
RP130N361D	J2C	3.6V
RP130N371D	J2D	3.7V
RP130N381D	J2E	3.8V
RP130N391D	J2F	3.9V
RP130N401D	J2G	4.0V
RP130N411D	J2H	4.1V
RP130N421D	J2J	4.2V
RP130N431D	J2K	4.3V
RP130N441D	J2L	4.4V
RP130N451D	J2M	4.5V
RP130N461D	J2N	4.6V
RP130N471D	J2P	4.7V
RP130N481D	J2Q	4.8V
RP130N491D	J2R	4.9V
RP130N501D	J2S	5.0V
RP130N511D	J2V	5.1V
RP130N521D	J2W	5.2V
RP130N531D	J2X	5.3V
RP130N121D5	J2U	1.25V
RP130N181D5	H2H	1.85V
RP130N281D5	H2U	2.85V

TEST CIRCUITS

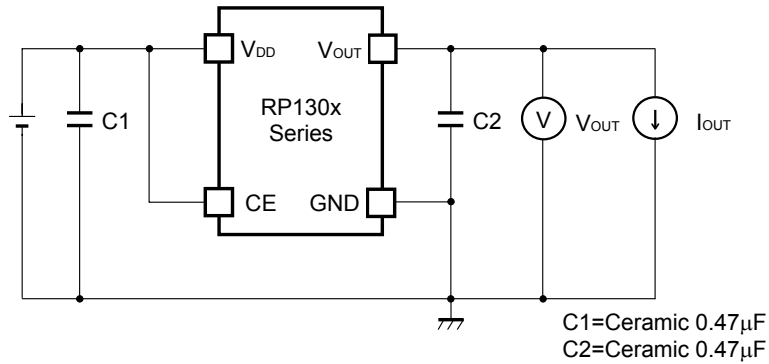

Basic Test Circuit

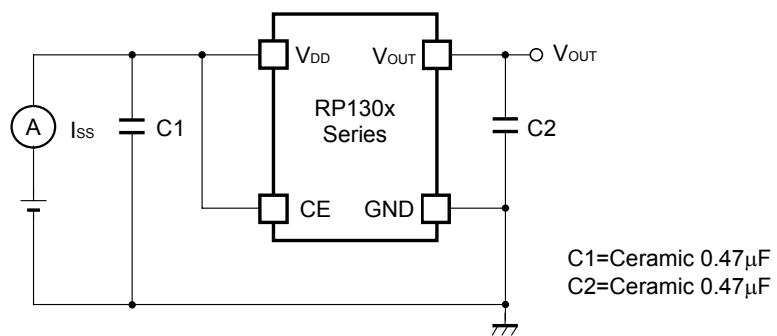

Supply Current Test Circuit

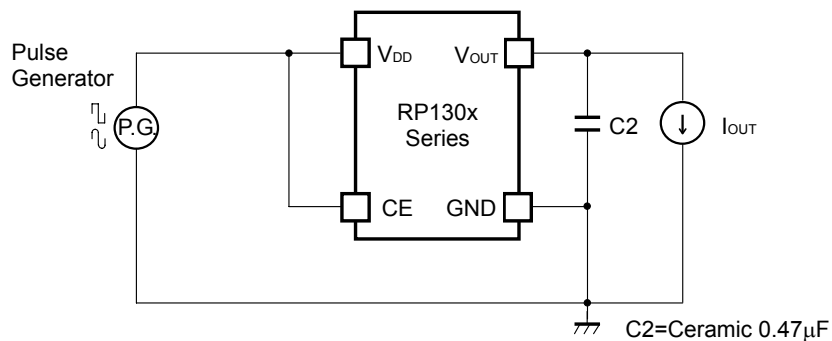

Ripple Rejection Test Circuit

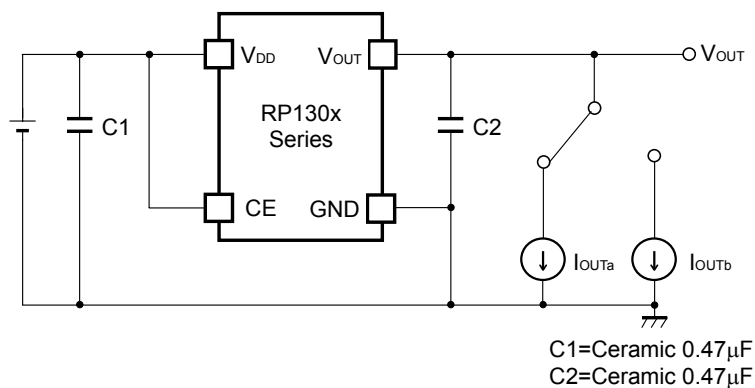

Load Transient Response Test Circuit

RP130x

NO.EA-173-131031

TYPICAL CHARACTERISTICS

1) Output Voltage vs. Output Current ($C1=0.47\mu\text{F}$, $C2=0.47\mu\text{F}$, $T_{opt}=25^\circ\text{C}$)

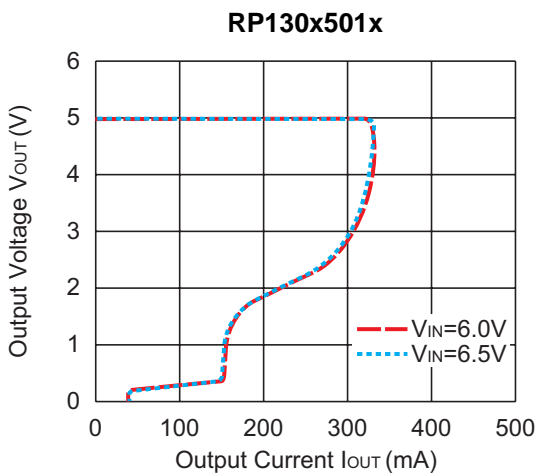
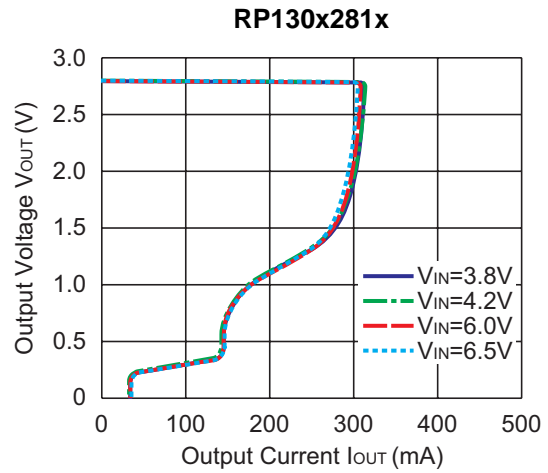
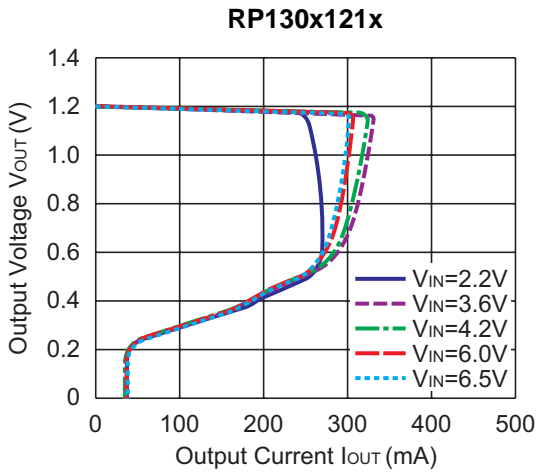

2) Output Voltage vs. Input Voltage ($C1=0.47\mu\text{F}$, $C2=0.47\mu\text{F}$, $T_{opt}=25^\circ\text{C}$)

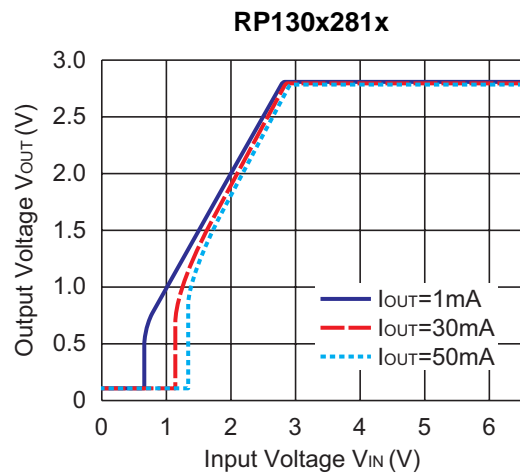
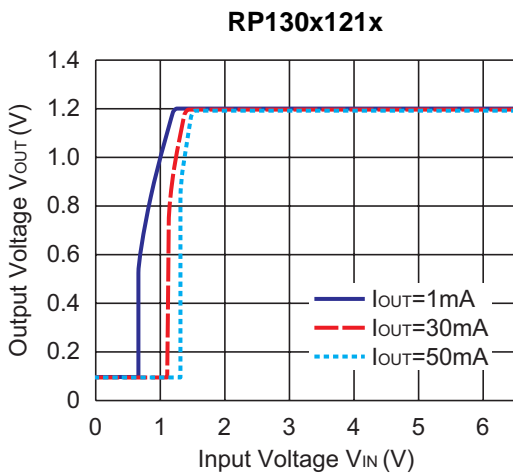

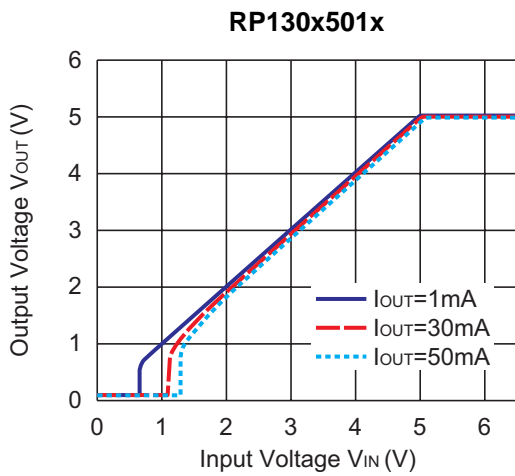

3) Supply Current vs. Input Voltage ($C1=0.47\mu F$, $C2=0.47\mu F$, $T_{opt}=25^{\circ}C$)

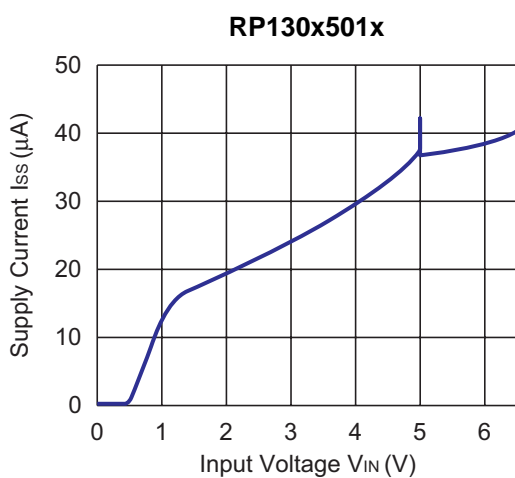
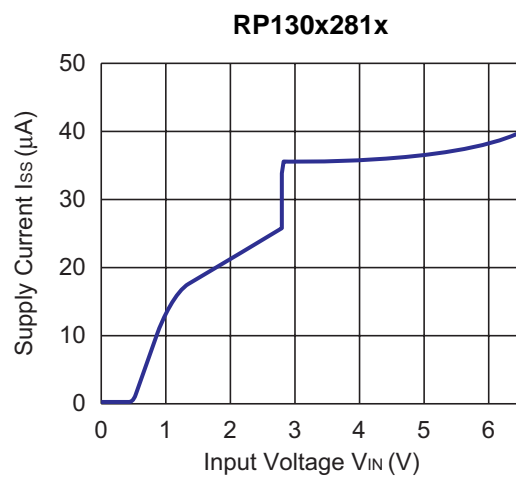
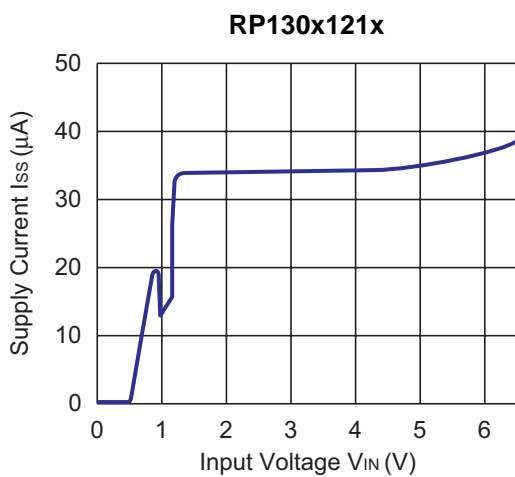

RP130x

NO.EA-173-131031

4) Output Voltage vs. Temperature ($I_{OUT}=1mA$, $C1=0.47\mu F$, $C2=0.47\mu F$)

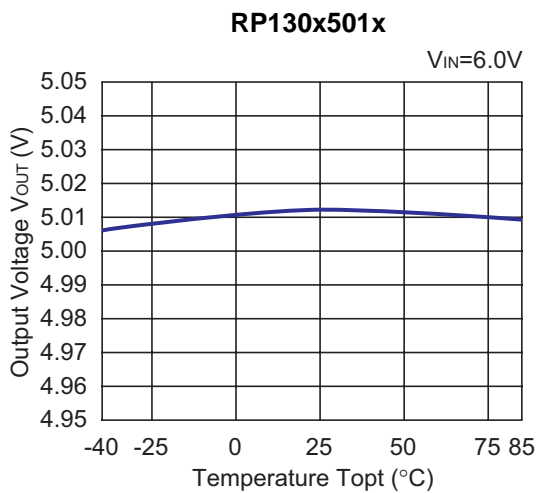
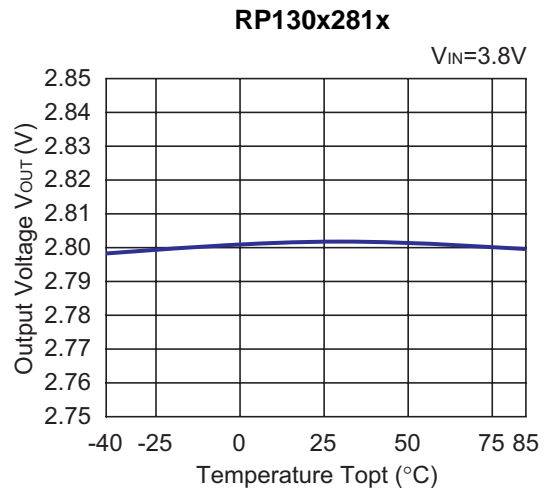
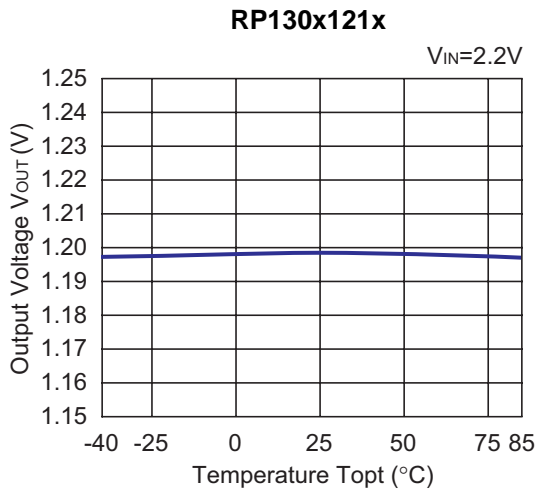

5) Supply Current vs. Temperature ($I_{OUT}=0mA$, $C1=0.47\mu F$, $C2=0.47\mu F$)

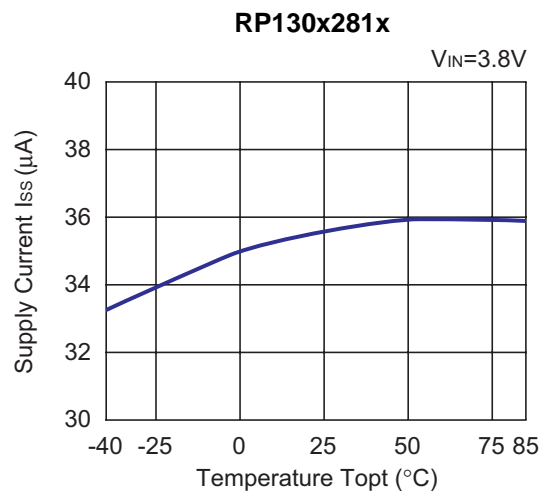
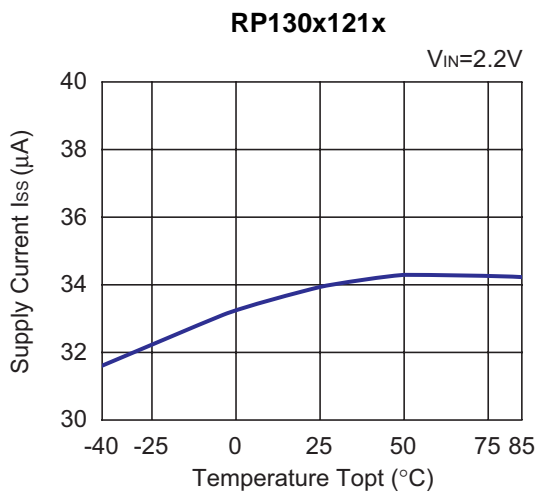

RP130x501x

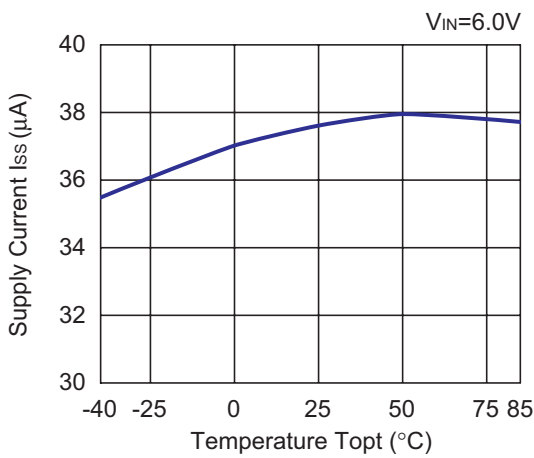

6) Dropout Voltage vs. Output Current ($C1=0.47\mu F$, $C2=0.47\mu F$)

RP130x121x

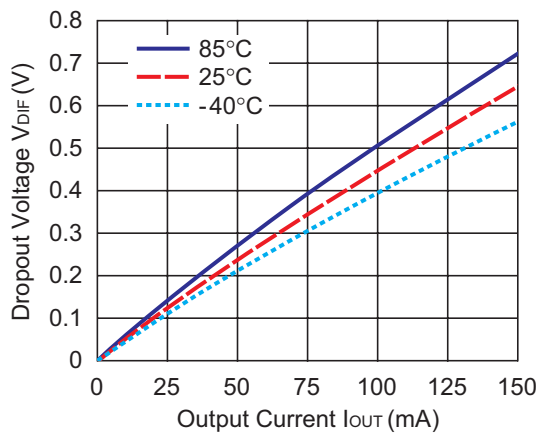

RP130x281x

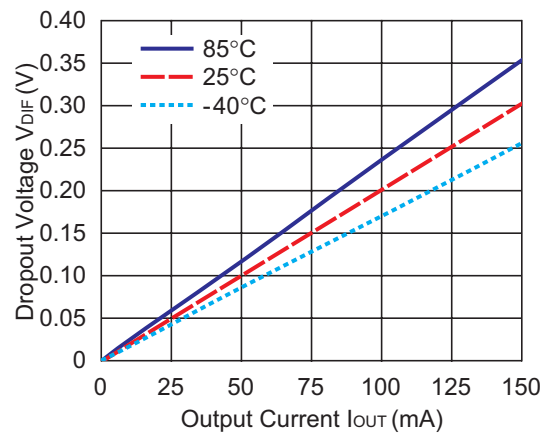

RP130x501x

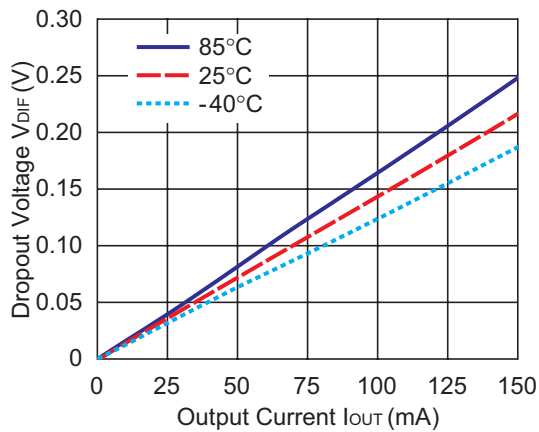

RP130x

NO.EA-173-131031

7) Dropout Voltage vs. Set Output Voltage (C1=0.47μF, C2=0.47μF)

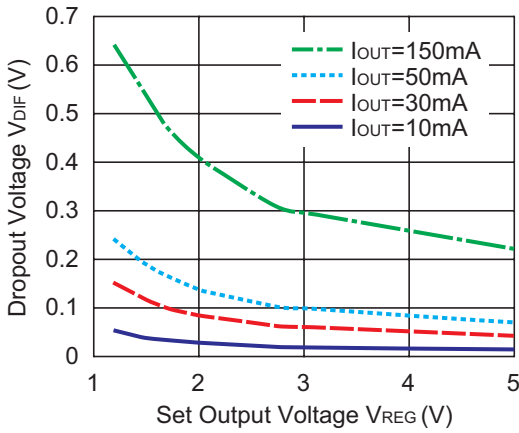

8) Ripple Rejection vs. Input Bias Voltage (C1=none, C2=0.47μF, Ripple=0.2V_{p-p}, T_{opt}=25°C)

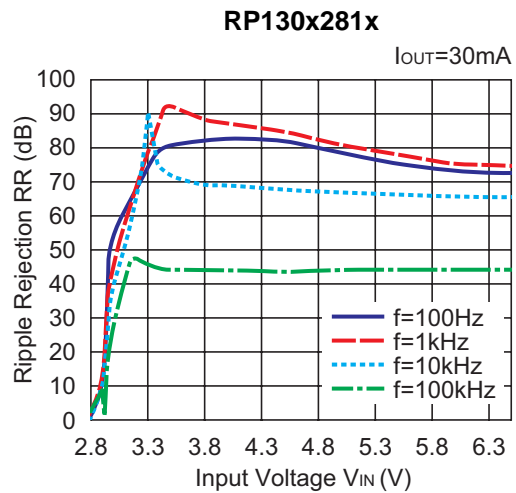
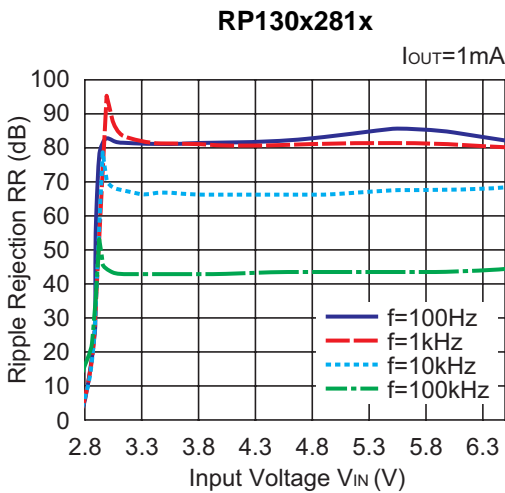

9) Ripple Rejection vs. Frequency (C1=none, C2=0.47μF, Ripple=0.2V_{p-p}, T_{opt}=25°C)

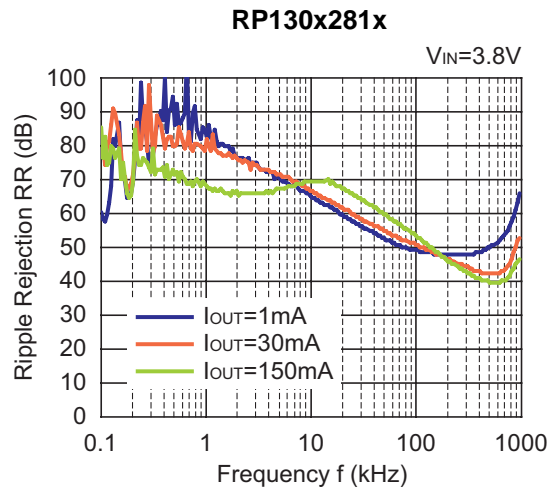
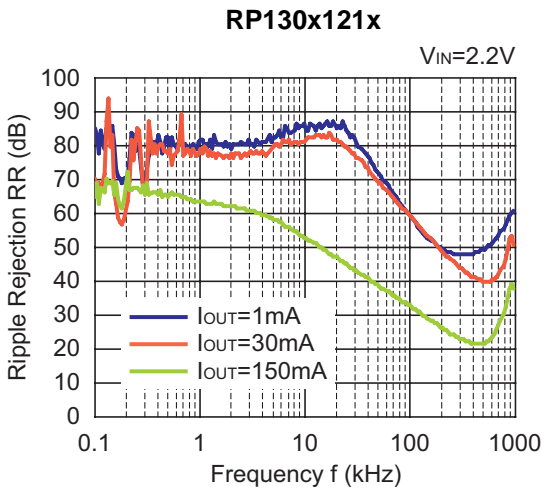

RP130x501x

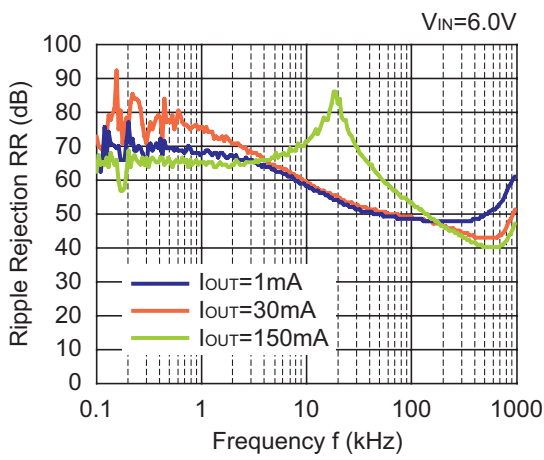

10) Input Transient Response ($I_{OUT}=30mA$, $t_r=tf=5\mu s$, $C1=none$, $C2=0.47\mu F$, $T_{opt}=25^\circ C$)

RP130x121x

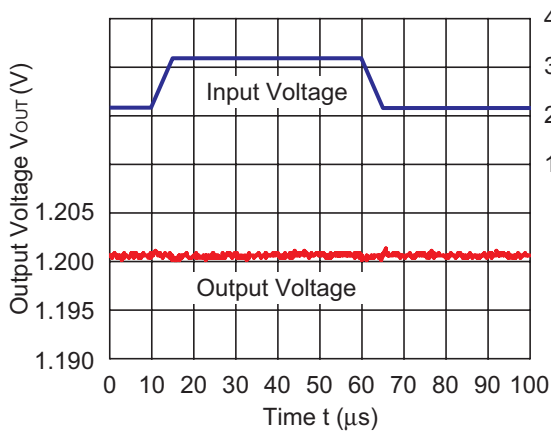

RP130x281x

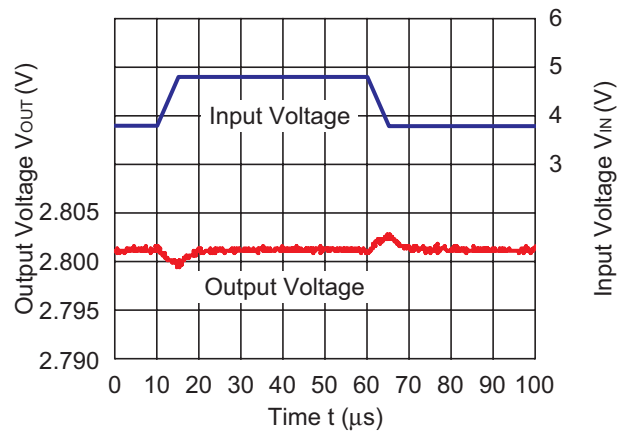

RP130x501x

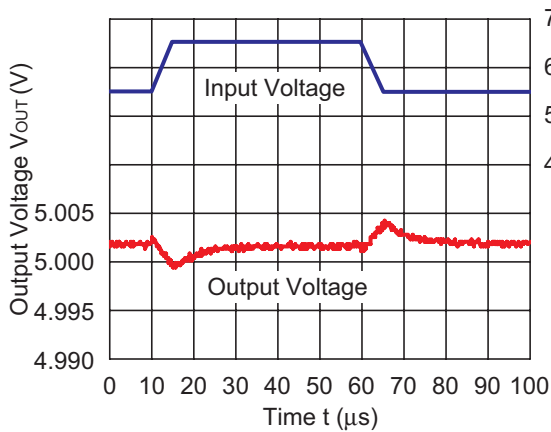

RP130x

NO.EA-173-131031

11) Load Transient Response ($t_r=t_f=0.5\mu s$, $C_1=0.47\mu F$, $C_2=0.47\mu F$, $I_{OUT}=50mA \leftrightarrow 100mA$, $T_{opt}=25^\circ C$)

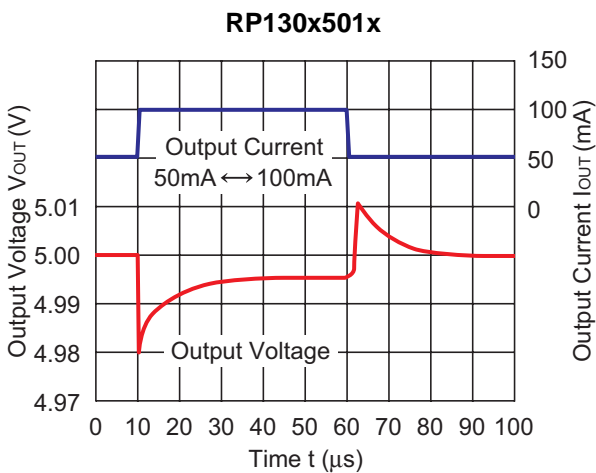
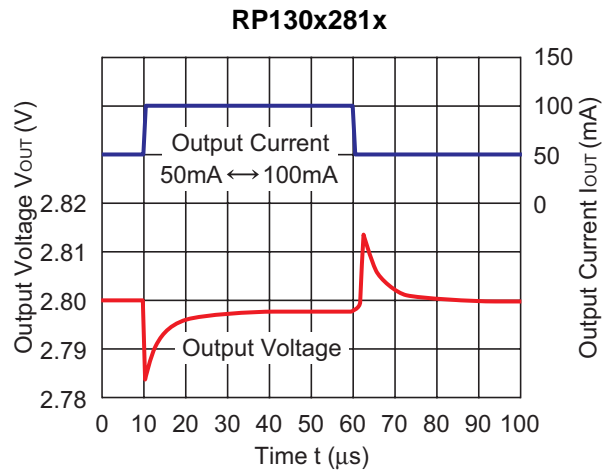
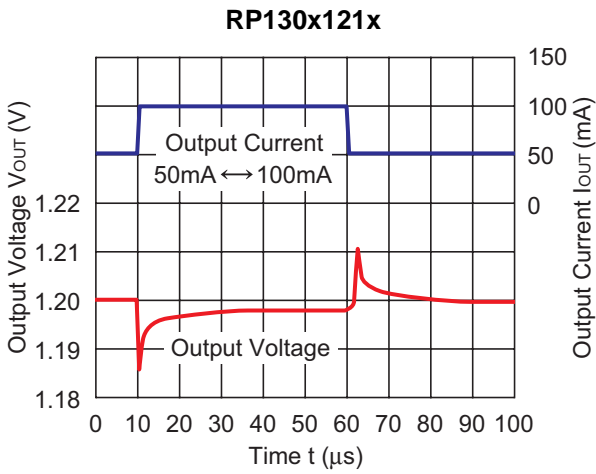

12) Load Transient Response ($t_r=t_f=0.5\mu s$, $C_1=0.47\mu F$, $C_2=0.47\mu F$, $I_{OUT}=1mA \leftrightarrow 150mA$, $T_{opt}=25^\circ C$)

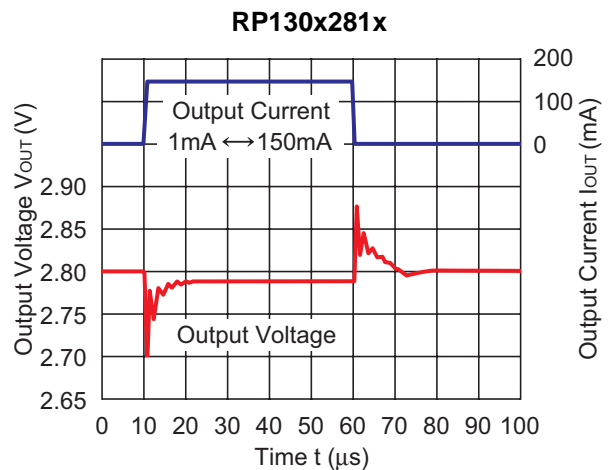
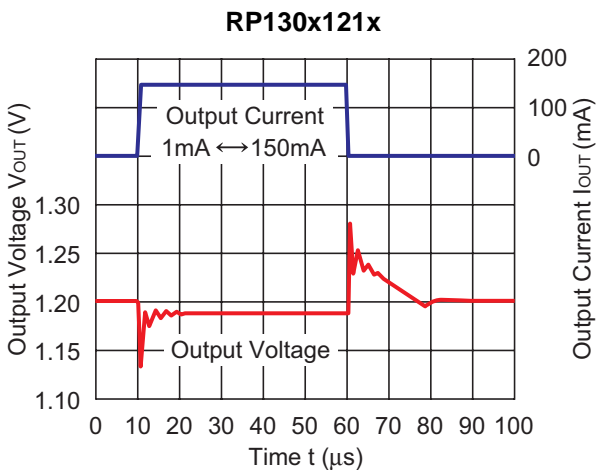

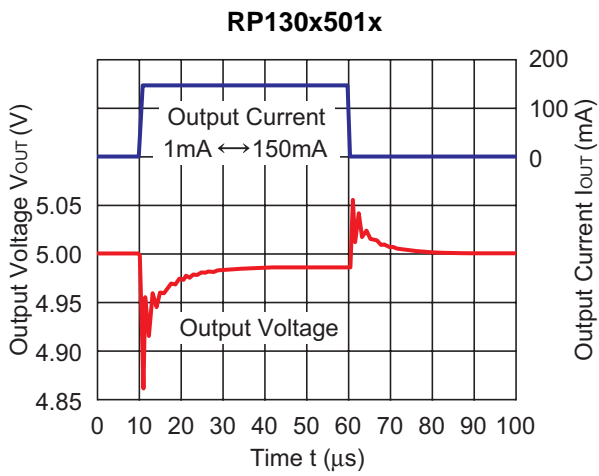

13) Turn On Speed with CE pin ($C1=0.47\mu$ F, $C2=0.47\mu$ F, $T_{opt}=25^{\circ}$ C)

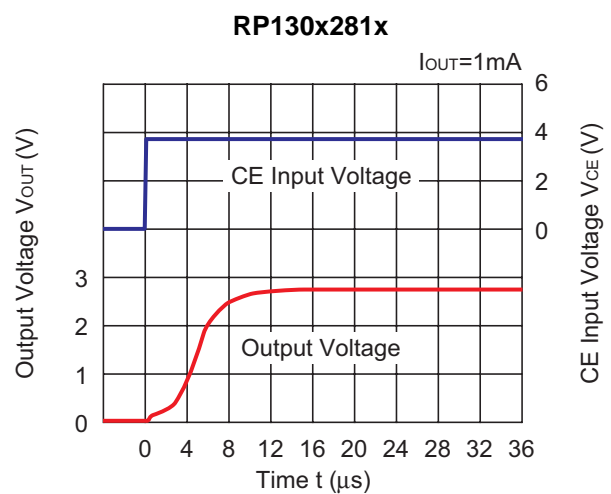
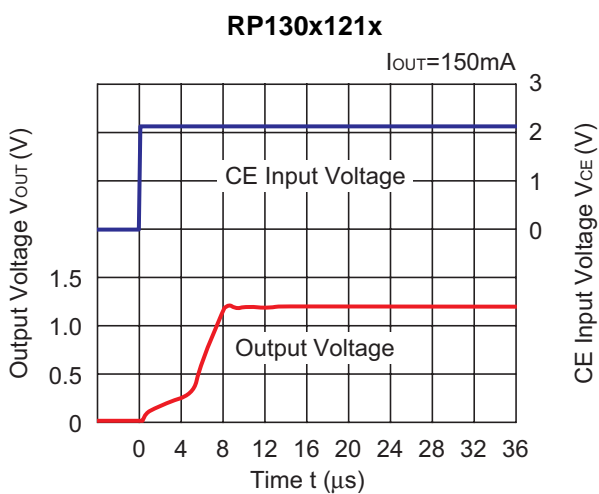
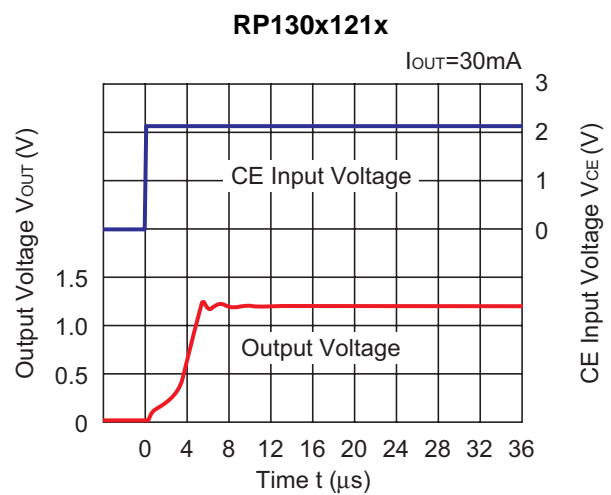
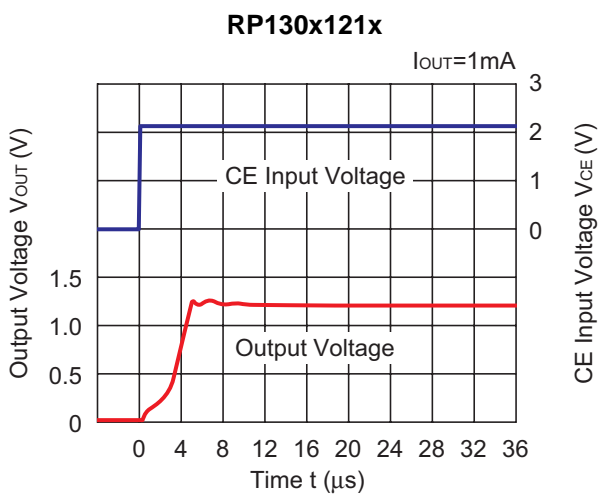

RP130x

NO.EA-173-131031

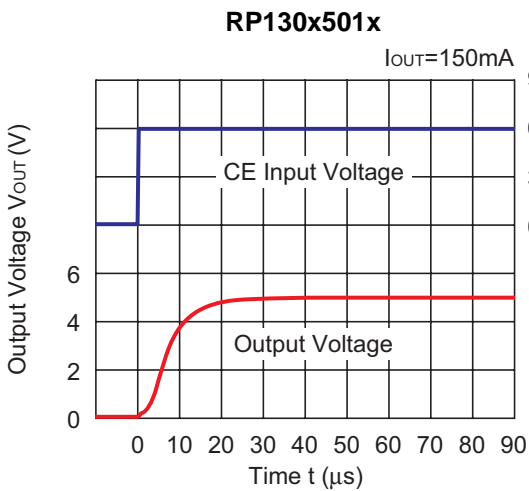
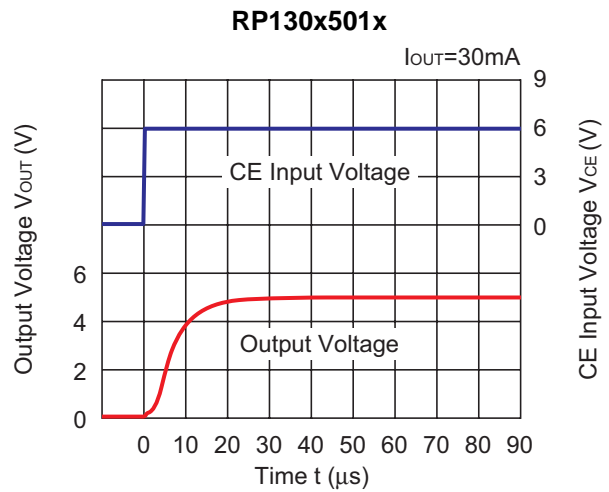
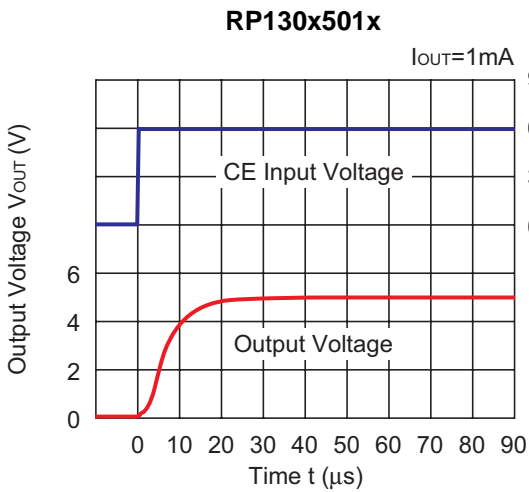
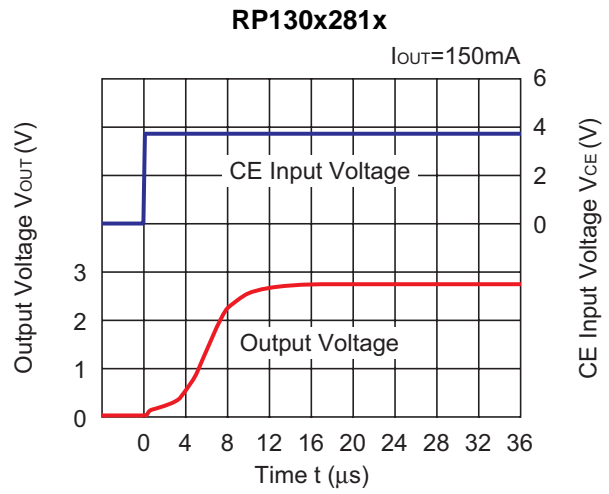
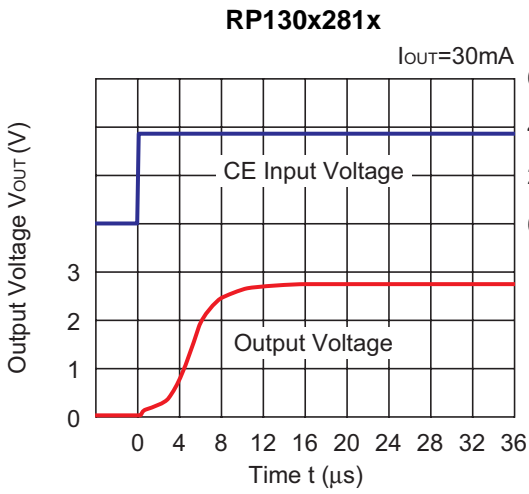

14) Turn Off Speed with CE pin (D Version) (C1=0.47μF, C2=0.47μF, T_{opt}=25°C)

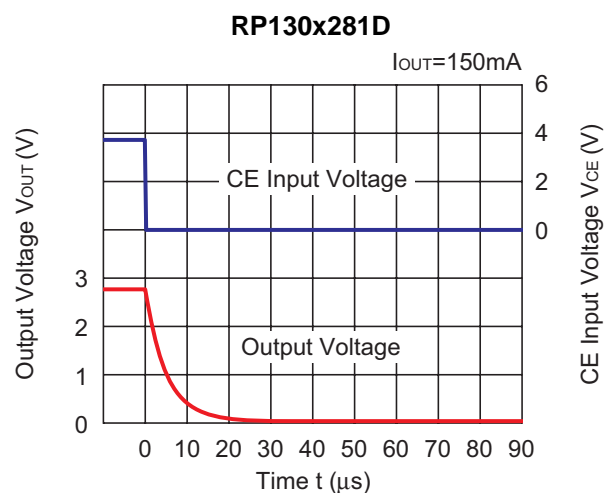
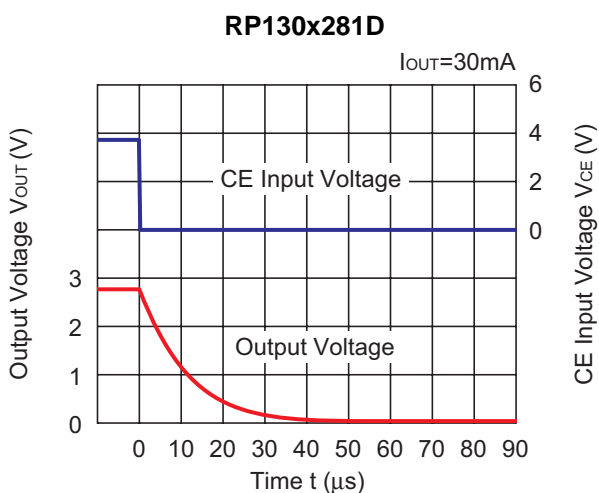
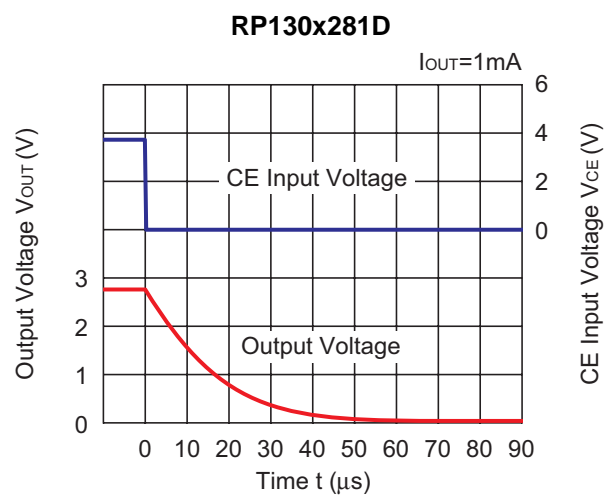
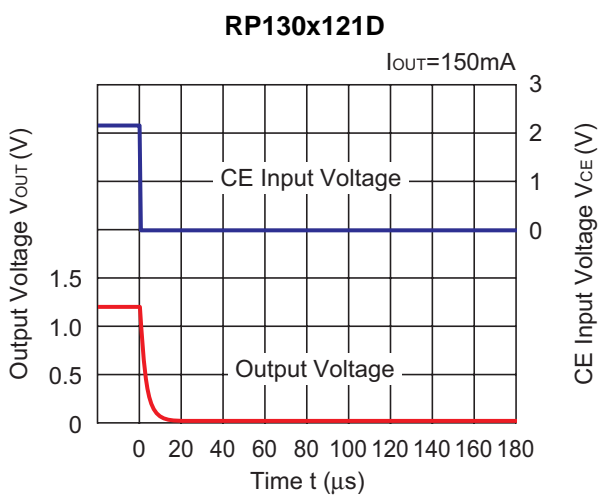
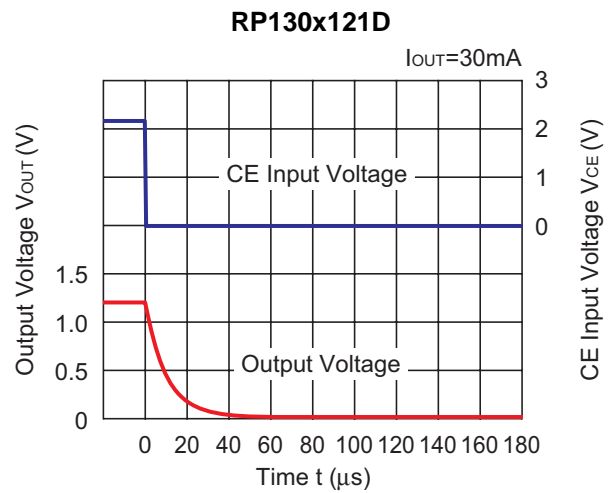
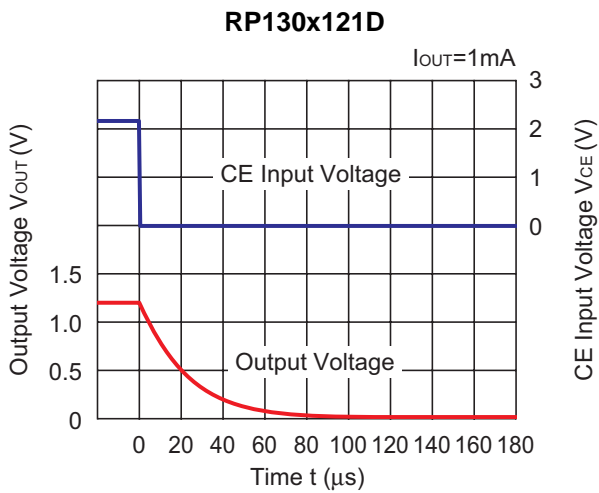

RP130x

NO.EA-173-131031

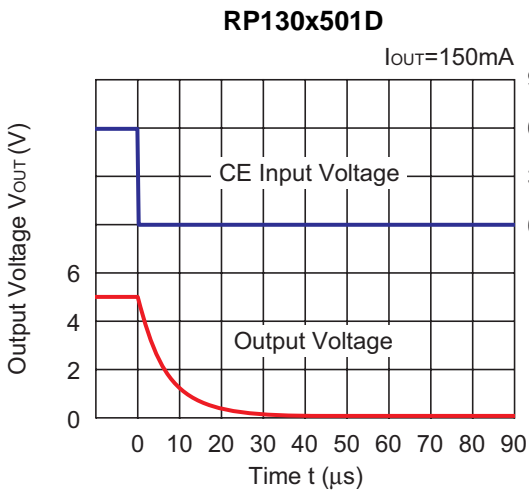
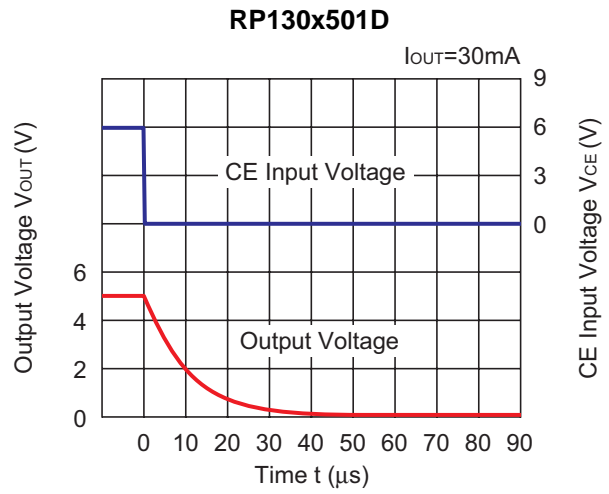
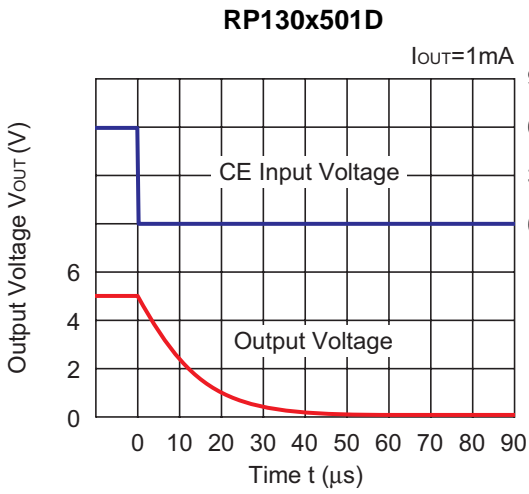

15) Minimum Operating Voltage ($C1=0.47\mu F$, $C2=0.47\mu F$)

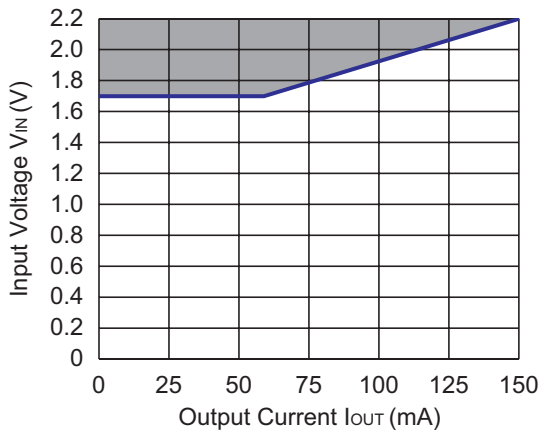

Hatched area is available for 1.2V output.

ESR vs. Output Current

When using these ICs, consider the following points:

The relations between I_{OUT} (Output Current) and ESR of an output capacitor are shown below.

The conditions when the white noise level is under $40\mu\text{V}$ (Avg.) are marked as the hatched area in the graph.

Measurement conditions

Frequency Band : 10Hz to 3MHz

Temperature : -40°C to 85°C

C1, C2 : $0.47\mu\text{F}$

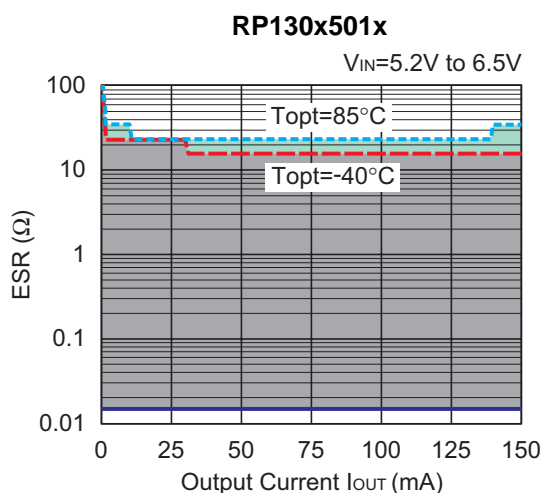
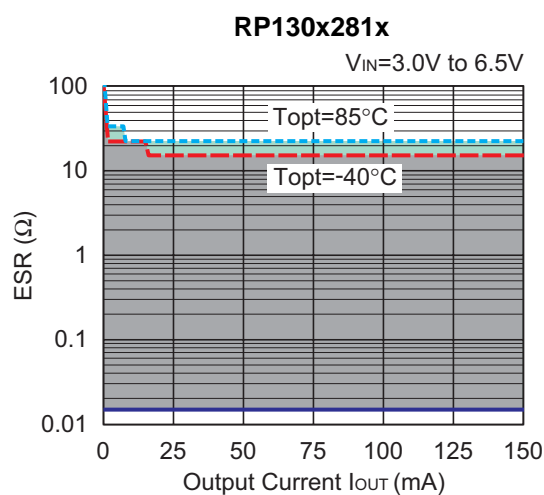
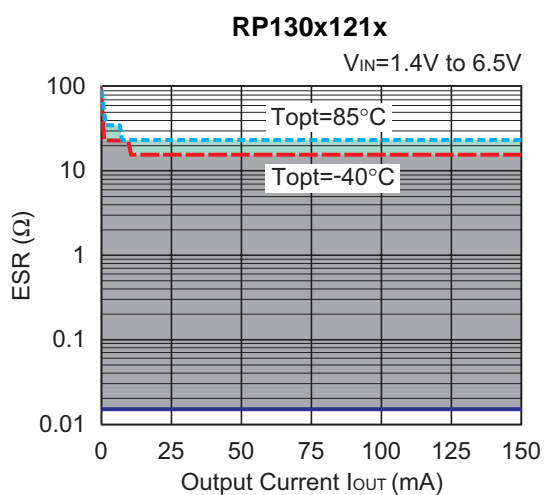



1. The products and the product specifications described in this document are subject to change or discontinuation of production without notice for reasons such as improvement. Therefore, before deciding to use the products, please refer to Ricoh sales representatives for the latest information thereon.
2. The materials in this document may not be copied or otherwise reproduced in whole or in part without prior written consent of Ricoh.
3. Please be sure to take any necessary formalities under relevant laws or regulations before exporting or otherwise taking out of your country the products or the technical information described herein.
4. The technical information described in this document shows typical characteristics of and example application circuits for the products. The release of such information is not to be construed as a warranty of or a grant of license under Ricoh's or any third party's intellectual property rights or any other rights.
5. The products listed in this document are intended and designed for use as general electronic components in standard applications (office equipment, telecommunication equipment, measuring instruments, consumer electronic products, amusement equipment etc.). Those customers intending to use a product in an application requiring extreme quality and reliability, for example, in a highly specific application where the failure or misoperation of the product could result in human injury or death (aircraft, spacevehicle, nuclear reactor control system, traffic control system, automotive and transportation equipment, combustion equipment, safety devices, life support system etc.) should first contact us.
6. We are making our continuous effort to improve the quality and reliability of our products, but semiconductor products are likely to fail with certain probability. In order to prevent any injury to persons or damages to property resulting from such failure, customers should be careful enough to incorporate safety measures in their design, such as redundancy feature, fire containment feature and fail-safe feature. We do not assume any liability or responsibility for any loss or damage arising from misuse or inappropriate use of the products.
7. Anti-radiation design is not implemented in the products described in this document.
8. Please contact Ricoh sales representatives should you have any questions or comments concerning the products or the technical information.



Ricoh is committed to reducing the environmental loading materials in electrical devices with a view to contributing to the protection of human health and the environment.

Ricoh has been providing RoHS compliant products since April 1, 2006 and Halogen-free products since April 1, 2012.

RICOH RICOH ELECTRONIC DEVICES CO., LTD.

<http://www.e-devices.ricoh.co.jp/en/>

Sales & Support Offices

RICOH ELECTRONIC DEVICES CO., LTD.

Higashi-Shinagawa Office (International Sales)
3-32-3, Higashi-Shinagawa, Shinagawa-ku, Tokyo 140-8655, Japan
Phone: +81-3-5479-2857 Fax: +81-3-5479-0502

RICOH EUROPE (NETHERLANDS) B.V.

Semiconductor Support Centre
Prof. W.H. Keesomlaan 1, 1183 DJ Amstelveen, The Netherlands
Phone: +31-20-5474-309

RICOH ELECTRONIC DEVICES KOREA CO., LTD.

3F, Haesung Bldg. 504, Teheran-ro, Gangnam-gu, Seoul, 135-725, Korea
Phone: +82-2-2135-5700 Fax: +82-2-2051-5713

RICOH ELECTRONIC DEVICES SHANGHAI CO., LTD.

Room 403, No.2 Building, No.690 Bilbo Road, Pu Dong New District, Shanghai 201203, People's Republic of China
Phone: +86-21-5027-3200 Fax: +86-21-5027-3299

RICOH ELECTRONIC DEVICES CO., LTD.

Taipei office
Room 109, 10F-1, No.51, Hengyang Rd., Taipei City, Taiwan (R.O.C.)
Phone: +886-2-2313-1621/1622 Fax: +886-2-2313-1623

www.s-manuals.com