



# Applications Note:AN\_SY8702

## High Efficiency 1MHz, 0.5A, 30V

### Step Down White LED Driver

#### Preliminary Specification

### General Description

SY8702 is a high efficiency step down regulator capable of driving 0.5A white LED from up to 30V input. It integrates the low  $R_{ON}$  MOSFET and internal compensation. The 1MHz switching frequency allows the use of very small inductor. This, along with the small SOT23-6 package, achieves an extremely small LED driver design.

### Features

- Wide input range: 2.5-30 V
- 1 MHz switching frequency
- Very low  $R_{ON}$ : 200m $\Omega$
- Enable and dimming control available
- Compact 6 pin SOT23 package
- RoHS Compliant and Halogen Free

### Ordering Information

SY8702□(□□)□  
 └─ Temperature Code  
 └─ Package Code  
 └─ Optional Spec Code

Temperature Range: -40°C to 85°C

Ordering Number	Package type	Note
SY8702ABC	SOT23-6	0.5A

### Applications

- Flash light
- Display cabinet lamp
- LED sign

### Typical Applications

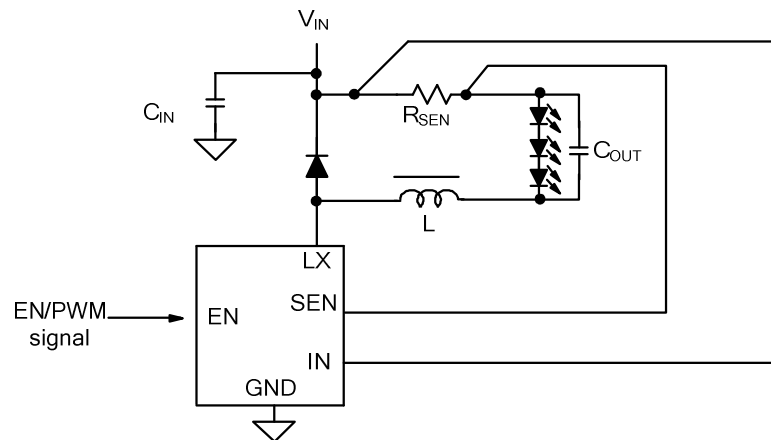
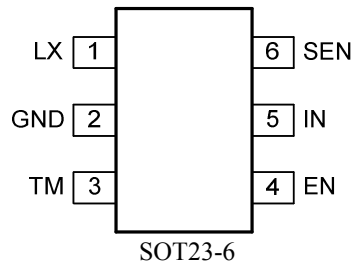

Figure 1. Schematic diagram

## Pinout (top view)



**Top Mark: DRxyz** (device code: DR, x=year code, y=week code, z=lot number code)

Pin Name	Pin Number	Pin Description
IN	5	Input pin. Decouple this pin to GND pin with 1uF ceramic cap. Also used as the positive current sense pin.
SEN	6	Negative Current Sense Pin.
GND	2	Ground pin
LX	1	Inductor node. Connect an inductor between IN pin and LX pin.
EN	4	Enable control pin. Can also apply low frequency digital signal to achieve PWM dimming function.
TM	3	Test mode pin. Ground this pin in the real application.

## Absolute Maximum Ratings (Note 1)

LX, IN-----	33V
SEN -----	$V_{IN} \pm 0.7V$
All other pins-----	4V
Power Dissipation, PD @ TA = 25°C SOT-23-6, -----	0.6W
Package Thermal Resistance (Note 2)	
$\theta_{JA}$ -----	250°C/W
$\theta_{JC}$ -----	130°C/W
Junction Temperature Range -----	150°C
Lead Temperature (Soldering, 10 sec.) -----	260°C
Storage Temperature Range -----	-65°C to 150°C

## Recommended Operating Conditions (Note 3)

IN, LX -----	2.5V to 30V
SEN -----	$V_{IN} \pm 0.5V$
All other pins -----	0-3.6V
Junction Temperature Range -----	-40°C to 125°C
Ambient Temperature Range -----	-40°C to 85°C



## Electrical Characteristics

( $V_{IN} = 5V$ ,  $I_{OUT} = 100mA$ ,  $T_A = 25^\circ C$  unless otherwise specified)

Parameter	Symbol	Test Conditions	Min	Typ	Max	Unit
Input Voltage Range	$V_{IN}$		2.5		30	V
Shutdown Current	$I_{SHDN}$	EN=0		5	10	$\mu A$
Low Side Main FET $R_{ON}$	$R_{DS(ON)1}$			200		$m\Omega$
Main FET Current Limit	$I_{LIM1}$		0.8			A
Switching Frequency	$F_{SW}$		0.8	1	1.2	MHz
Current Sense Limit	$V_{IN-SEN}$		96	100	104	mV
EN Rising Threshold	$V_{ENH}$		1.5			V
EN Falling Threshold	$V_{ENL}$				0.4	V
IN UVLO Rising Threshold	$V_{IN,UVLO}$				2.5	V
UVLO Hysteresis	$U_{VLO,HYS}$			0.1		V
Thermal Shutdown Temperature	$T_{SD}$			150		C
Max Duty Cycle			88	90		%
Min Duty Cycle				10	12	%

**Note 1:** Stresses listed as the above “Absolute Maximum Ratings” may cause permanent damage to the device. These are for stress ratings. Functional operation of the device at these or any other conditions beyond those indicated in the operational sections of the specifications is not implied. Exposure to absolute maximum rating conditions for extended periods may remain possibility to affect device reliability.

**Note 2:**  $\theta_{JA}$  is measured in the natural convection at  $T_A = 25^\circ C$  on a low effective single layer thermal conductivity test board of JEDEC 51-3 thermal measurement standard.

**Note 3.** The device is not guaranteed to function outside its operating conditions

## Block Diagram

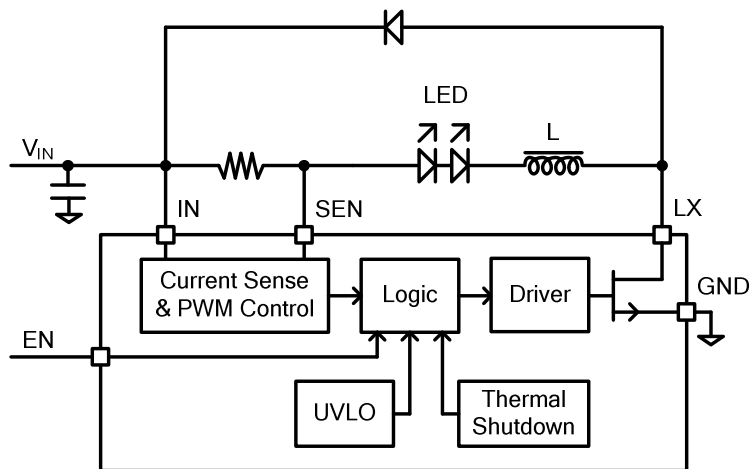

## Typical Performance Characteristics

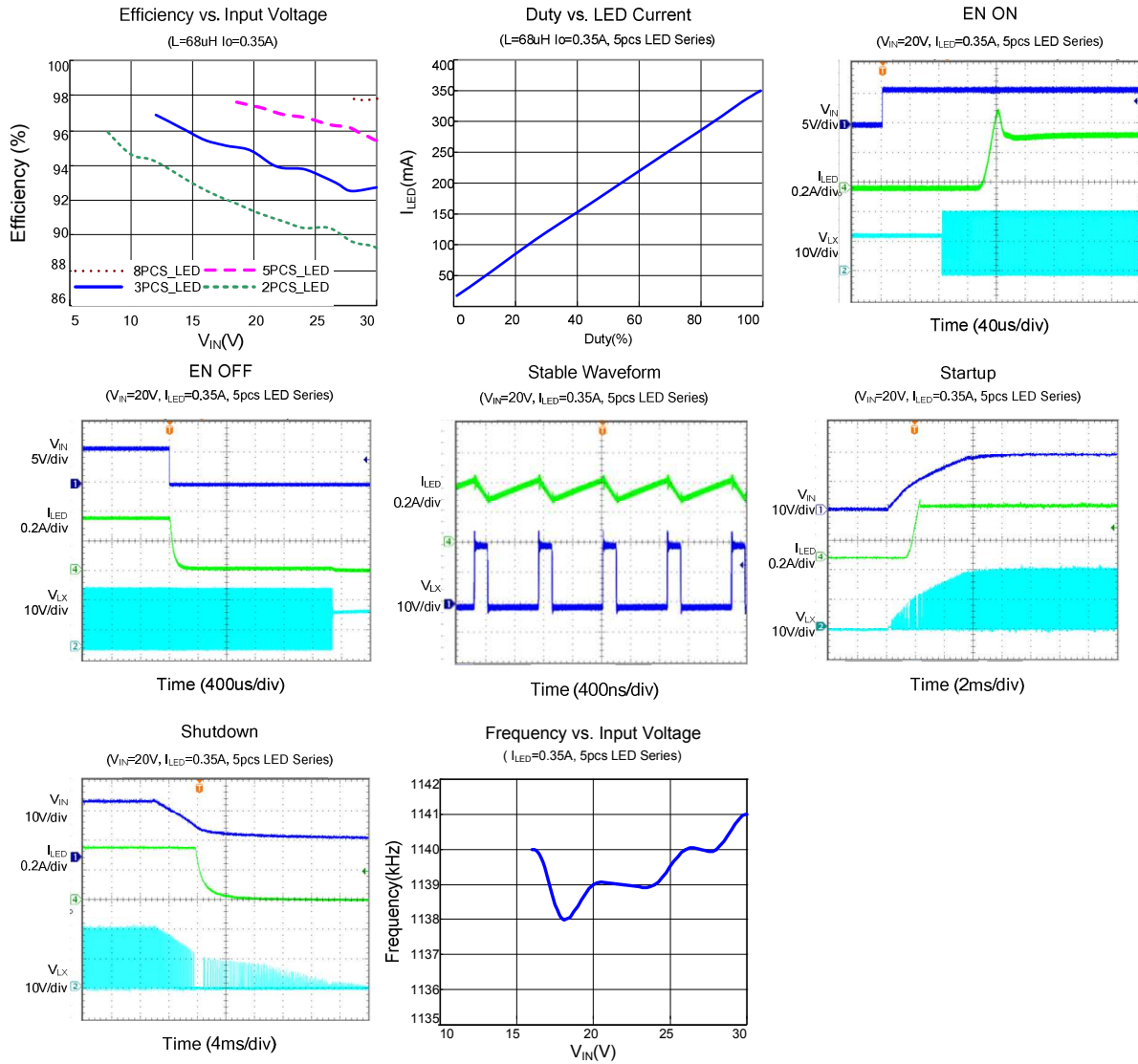



## Operation

SY8702 is a floating buck regulator IC that integrates the PWM control, power MOSFET on the same die to minimize the switching transition loss and conduction loss. With ultra low  $R_{DS(ON)}$  power switches and proprietary PWM control, this regulator IC can achieve the high efficiency and the high switch frequency simultaneously to minimize the external inductor and capacitor size, and thus achieving the minimum solution footprint.

## Applications Information

Because of the high integration in the SY8702 IC, the application circuit based on this regulator IC is rather simple. Only input capacitor  $C_{IN}$ , output capacitor  $C_{OUT}$ , output inductor  $L$  and current sense resistor  $R_{SEN}$  need to be selected for the targeted applications specifications.

### Current sense resistor $R_{SEN}$ :

Choose  $R_{SEN}$  to program the proper output Current:

$$I_{LED}(A) = \frac{0.1(V)}{R_{SEN}(\Omega)}$$

### Input capacitor $C_{IN}$ :

The ripple current through input capacitor is calculated as:

$$I_{CIN\_RMS} = I_{OUT} \cdot \sqrt{D(1-D)}$$

A typical X7R or better grade ceramic capacitor with suitable capacitance should be chosen to handle this ripple current well. To minimize the potential noise problem, place this ceramic capacitor really close to the IN and GND pins. Care should be taken to minimize the loop area formed by  $C_{IN}$ , and IN/GND pins.

### Output capacitor $C_{OUT}$ :

The output capacitor is selected to handle the output current ripple noise requirements. For the best performance, it is recommended to use X7R or better grade ceramic capacitor greater than 1uF capacitance.

### Output inductor $L$ :

There are several considerations in choosing this inductor.

- 1) Choose the inductance to provide the desired ripple current. It is suggested to choose the ripple current to be about 40% of the maximum output current. The inductance is calculated as:

$$L = \frac{V_{OUT}(1 - V_{OUT}/V_{IN,MAX})}{F_{SW} \times I_{OUT,MAX} \times 40\%}$$

where  $F_{sw}$  is the switching frequency and  $I_{OUT,MAX}$  is the LED current.

The SY8702 regulator IC is quite tolerant of different ripple current amplitude. Consequently, the final choice of inductance can be slightly off the calculation value without significantly impacting the performance.

- 2) The saturation current rating of the inductor must be selected to be greater than the peak inductor current under full load conditions.

$$I_{SAT, MIN} > I_{OUT, MAX} + \frac{V_{OUT}(1 - V_{OUT}/V_{IN,MAX})}{2 \cdot F_{SW} \cdot L}$$



### **Layout Design:**

The layout design of SY8702 regulator is relatively simple. For the best efficiency and minimum noise problems, we should place the following components close to the IC:  $C_{IN}$ ,  $L$ ,  $C_{OUT}$  and  $R_{SEN}$ .

- 1) It is desirable to maximize the PCB copper area connecting to GND pin to achieve the best thermal and noise performance. If the board space allowed, a ground plane is highly desirable.
- 2)  $C_{IN}$  must be close to Pins IN and GND. The loop area formed by  $C_{IN}$  and GND must be minimized.
- 3) The PCB copper area associated with LX pin must be minimized to avoid the potential noise problem.

## SOT23-6 Package Outline & PCB layout

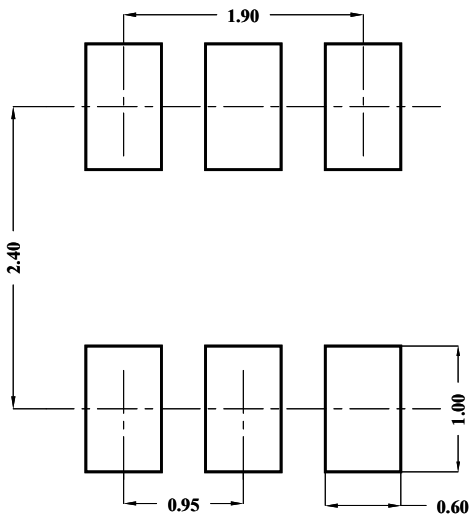

Recommended Pad Layout

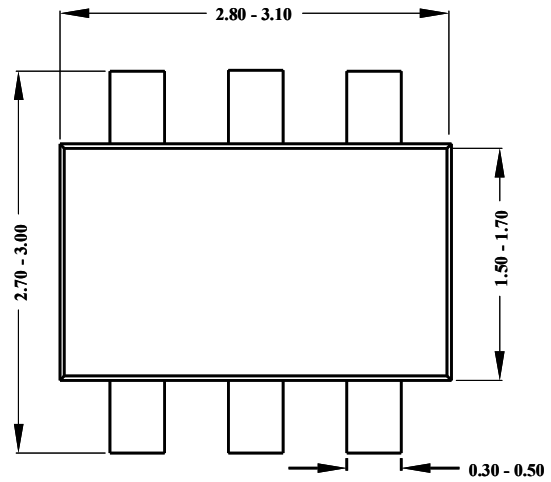

Top View

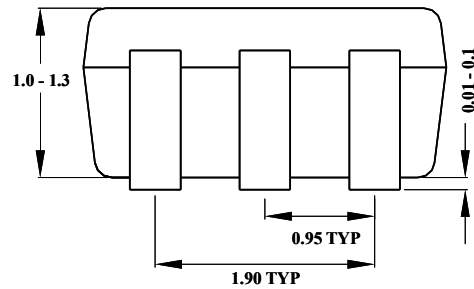
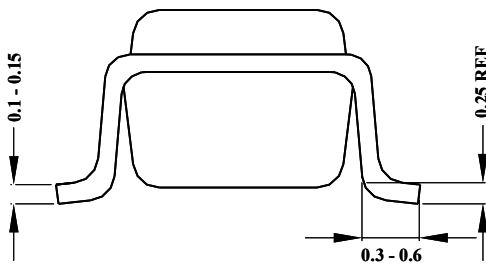

**Notes: All dimensions are in millimeters.  
All dimensions don't include mold flash & metal burr.**

[www.s-manuals.com](http://www.s-manuals.com)