

Constant Voltage and Constant Current Controller For Battery Chargers and Adaptors

SOT-26



Pin Definition:

- | | |
|---------------|----------------|
| 1. V_{CTRL} | 6. V_{CC} |
| 2. V_{ND} | 5. V_{SENSE} |
| 3. Out | 4. I_{CTRL} |

General Description

TS1052 is a highly integrated solution for SMPS applications requiring CV (constant voltage) and CC (constant current) mode. TS1052 integrated one voltage reference, two operational amplifiers, and a current sensing circuit. The voltage reference combined with one operational amplifier make it an ideal voltage controller, and the other low voltage reference combined with the other operational amplifier make it an ideal current limiter for output low side current sensing.

The current threshold is fixed, and precise. The only external components are:

- * A resistor bridge to be connected to the output of the power supply (Adapter, battery charger) to set the voltage regulation by dividing the desired output voltage to match the internal voltage reference value.
- * A sense resistor having a value and allowable dissipation power which need to be chosen according to the internal voltage threshold.

Features

- Constant Voltage and Constant Current Control
- Low Voltage Operation
- Precision Internal Voltage Reference
- Low External Component Count
- Current Sink Output Stage
- Easy Compensation
- Low AC Mains Voltage Rejection

Application

- Battery Charger
- Adaptors

Ordering Information

Part No.	Package	Packing
TS1052CX6 RFG	SOT-26	3Kpcs / 7" Reel

Note: "G" denotes for Halogen free products

Block Diagram

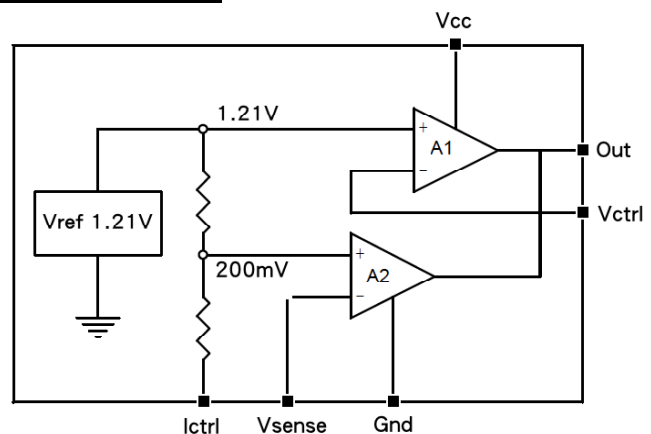

Pin Function Description

Name	Type	Function
V_{CTRL}	Analog Input	Input Pin of the Voltage Control Loop
V_{ND}	Power Supply	Ground Line. 0V Reference For All Voltage
Out	Current Sink Output	Output Pin. Sinking Current Only
I_{CTRL}	Analog Input	Input Pin of the Current Control Loop
V_{SENSE}	Analog Input	Input Pin of the Current Control Loop
V_{CC}	Power Supply	Position Power Supply Line

Constant Voltage and Constant Current Controller For Battery Chargers and Adaptors

Absolute Maximum Rating

Parameter	Symbol	Value	Unit
DC Supply Voltage	V_{CC}	20	V
Input Voltage	V_{IN}	-0.3 to V_{CC}	V
Operating Temperature	T_{OP}	0 to +85	°C
Maximum Junction Temperature Range	T_J	150	°C
Thermal Resistance Junction to Ambient	$R\theta_{ja}$	250	°C/W

Operating Condition

Parameter	Symbol	Value	Unit
DC Supply Voltage	V_{CC}	2.5 to 18	V

Electrical Specifications ($T_A=25^\circ\text{C}$, $V_{IN}=5\text{V}$ unless otherwise noted)

Parameter	Symbol	Min	Typ	Max	Unit
Total Current Consumption					
Total Supply Current – not taking the output sinking current into account	I_{CC}	--	1.1	2	mA
Voltage Control Loop					
Trans-conduction Gain (V_{ctrl}) sink Current Only (Note 1)	G_{MW}	1	3.5	--	mA/mV
Voltage Control Loop Reference (Note 2)	V_{REF}	1.198	1.21	1.222	V
Input Bias Current (V_{ctrl})	I_{IBV}	--	50	--	nA
Current Control Loop					
Trans-conduction Gain (I_{ctrl}) sink Current only (Note 3)	G_{MI}	1.5	7	--	mA/mV
Current Control Loop Reference, (Note 4) $I_{OUT}=2.5\text{A}$,	V_{SENSE}	196	200	204	mV
Current Out of Pin I_{ctrl} at – 200mV	I_{IBI}	--	25	--	μA
Output Stage					
Low Output Voltage at 10mA sinking Current	V_{OL}	--	200	--	mV
Output Short Circuit Current. Output to V_{CC} . Sink Current Only	I_{OS}	--	27	50	mA

Note 1: If the Voltage on V_{ctrl} (the negative input of the amplifier) is higher than the positive amplifier input (V_{ref} 1.21V), and it is increased by 1mV, the sinking current at the output will be increased by 3.5mA.

Note 2: The internal Voltage reference is set at 1.21V (bandgap reference). The voltage control loop precision takes into account the cumulative effects of the internal voltage reference deviation as well as the input offset voltage of the trans-conductance operational amplifier. The internal voltage reference is fixed by bandgap, and trimmed to 0.5% accuracy at room temperature.

Note 3: When the positive input at I_{ctrl} is lower than -200mV, and the voltage is decreased by 1mV, the sinking current at the output will be increased by 7mA

Note 4: The internal current sense threshold is set to -200mV. The current control loop precision takes into account the cumulative effects of the internal voltage reference deviation as well as the input offset voltage of the trans-conduction operational amplifier

Typical Adapter or Battery Charger Application Circuit

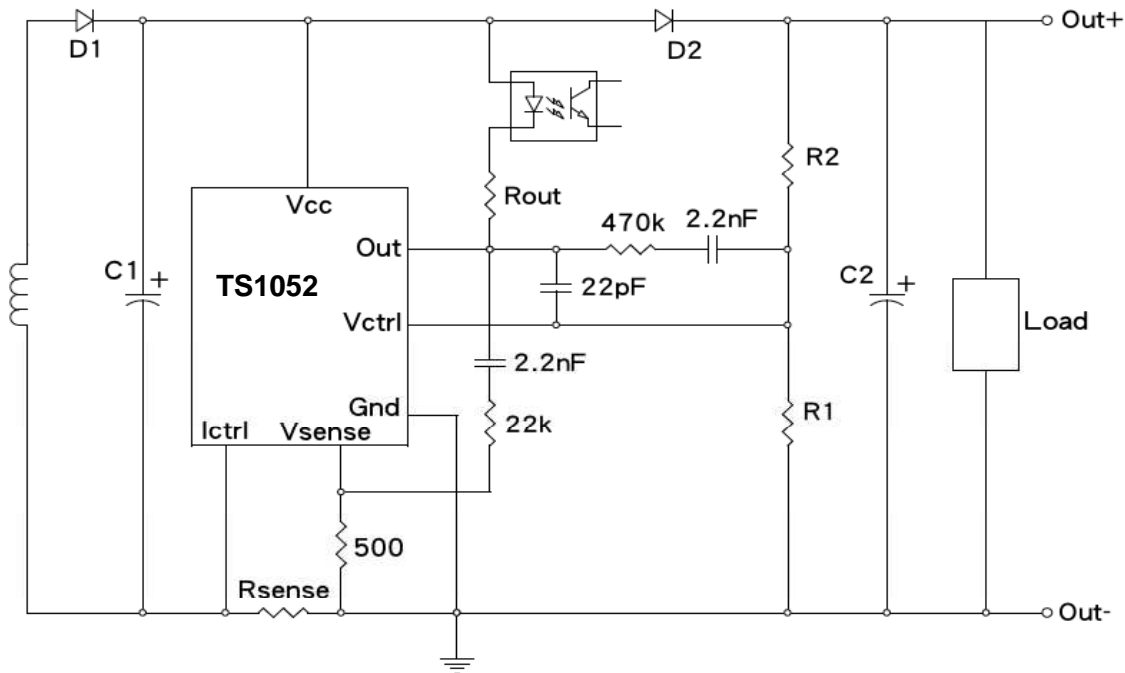

* In the above application schematic, the TS1052 is used on the secondary side of a fly-back adapter (or battery charger) to provide an accurate control of voltage and current. The above feedback loop is made with an optocoupler.

Principle of Operation and Application Hints

Voltage Control

The voltage loop is controlled via a first trans-conductance operational amplifier, the resistor bridge R1, R2, and the optocoupler which is directly connected to the output.

The relation between the values of R1 & R2 should be chosen as following:

$$*R1=R2 \times Vref / (Vout-Vref)$$

Where Vout is the desired output voltage.

To Avoid the discharge of the load, the resistor bridge R1 & R2 should be highly resistive. For this type of application, a total value of 100KΩ (or more) would be appropriate for the resistors R1 & R2. As an example, with R2=100KΩ, Vout=4.10V, Vref=1.21V, then R1=41.9KΩ.

Note that if the low drop diode should be inserted between the load and the voltage regulation resistor bridge to avoid current flowing from the load through the resistor bridge, this drop should be taken into account into the above calculations by replacing Vout by (Vout + Vdrop).

Constant Voltage and Constant Current Controller For Battery Chargers and Adaptors

Principle of Operation and Application Hints (continues)

Current Control

The current loop is controlled via the second trans-conductance operational amplifier, the sense resistor R_{sense} , and the optocoupler. The control verifies as following

* $R_{sense} \times I_{lim} = V_{sense}$

* $R_{sense} = V_{sense} / I_{lim}$

I_{lim} is the desired limited current, V_{sense} is the threshold voltage for the current control loop.

As an example, with $I_{lim} = 1A$, $V_{sense} = -200mV$, then $R_{sense} = 200m\Omega$.

Note that the R_{sense} resistor should be chosen taking into account the maximum dissipation (P_{lim}) through it during full load operation.

* $P_{lim} = V_{sense} \times I_{lim}$

As an example, with $I_{lim}=1A$, and $V_{sense}=200mV$, $P_{lim}=200mW$.

Therefore, for most adapter and battery charger applications, a quarter-watt, or half-watt resistor to make the current sensing function is sufficient.

V_{sense} threshold is achieved internally by a resistor bridge tied to the V_{ref} voltage reference. Its middle point is tied to the positive input of the current control operational amplifier, and its foot is to be connected to lower potential point of the sense resistor as shown on the following figure. The resistors of this bridge are matched to provide the best precision possible. The current sinking outputs of the two trans-conductance operational amplifiers are common (to the output of the IC). This makes an Oring function which ensures that whenever the current or the voltage reaches too high values, the optocoupler is activated.

The relation between the controlled current and the controlled output voltage can be described with a square characteristic as shown in the following V/I output-power graph

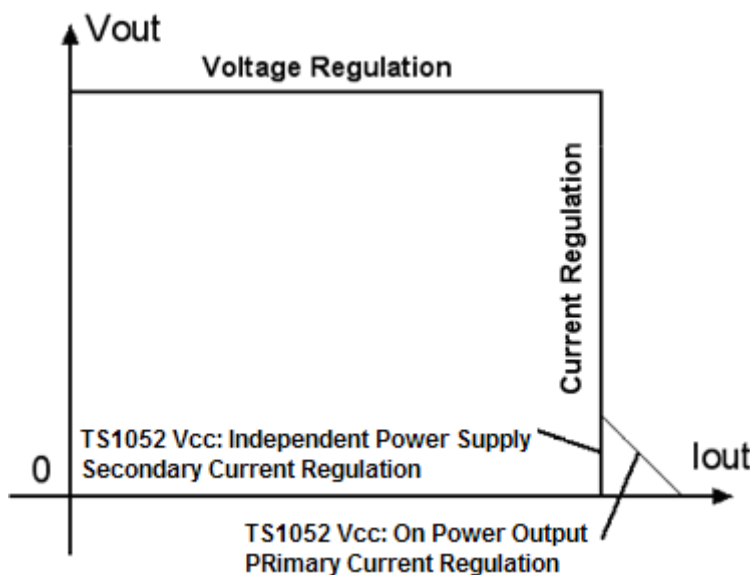

Output Voltage vs. Output Current

Constant Voltage and Constant Current Controller For Battery Chargers and Adaptors

Principle of Operation and Application Hints (continues)

Compensation

The voltage control trans-conductance operational amplifier can be fully compensated. Both of its output and negative input are directly accessible for external compensation components.

And example of a suitable compensation network is shown in typical application circuit. It consists of a capacitor $C_{vc1}=2.2nF$ and a resistor $R_{cv1}=470K\Omega$ in series, connected in parallel with another capacitor $C_{vc2}=22pF$.

The current control trans-conductance operational amplifier can be fully compensated. Both of its output and negative input are directly accessible for external compensation components. An example of suitable compensation network is shown in typical application circuit. It consists of a capacitor $C_{ic1}=2.2nF$ and resistor $R_{ic1}=22K\Omega$ in series. When the V_{cc} voltage reaches 18V it could be interesting to limit the current coming through the output in the aim to reduce the dissipation of the device and increase the stability performances of the whole application. An example of suitable R_{out} value could be 330Ω in series with the optocoupler in case $V_{cc}=12V$.

Start Up and Short Circuit Conditions

The TS1052 is not provided with a high enough supply voltage in under start-up or short-circuit conditions. This is due to the fact that the chip has its power supply line in common with the power supply line of the system. Therefore, the current limitation can only be ensured by the primary PWM module, which should be chosen accordingly. If the Primary current limitation is considered not to be precise enough for the application, then a sufficient supply for the TS1052 has to be ensured under any condition. It would then be necessary to add some circuitry to supply the chip with separate power line. This can be achieved in numerous ways, including an additional winding on the transformer. The following schematic shows how to realize a low-cost power supply for the TS1052 (with no additional windings). Please pay attention to the fact that in the particular case presented here, this low-cost power supply can reach voltages as high as twice the voltage of the regulated line. Since the absolute maximum rating of the TS1052 supply voltage is 18V, this low-cost auxiliary power supply can only be used in applications where the regulated line voltage does not exceed 9V.

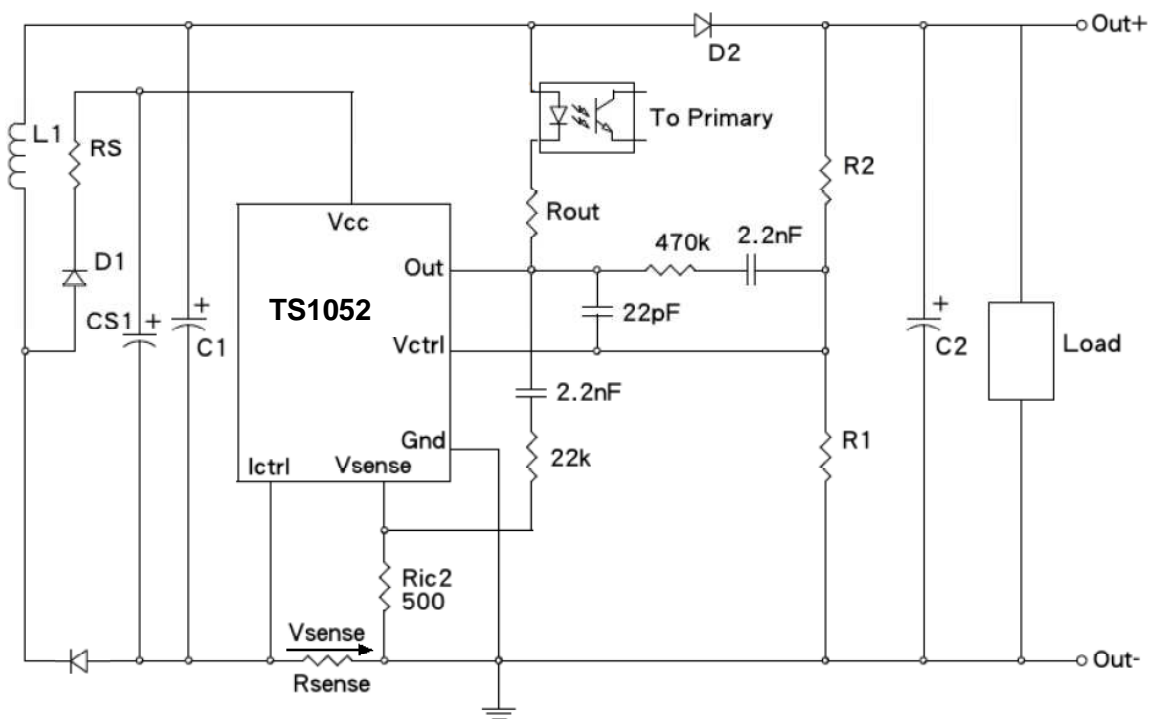

Electrical Characteristics Curve

FIGURE 1 – Vref vs Ambient Temperature

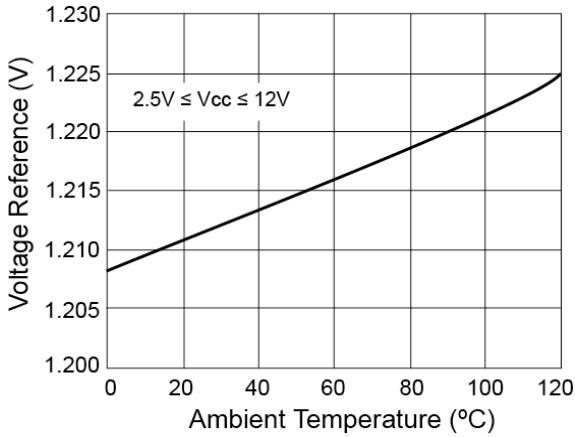

FIGURE 2 – Vsense vs Ambient Temperature

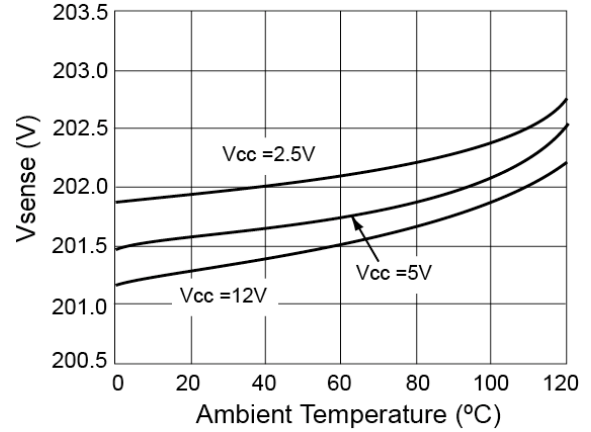

FIGURE 3 – Vsense Input Bias Current vs. Ambient Temperature

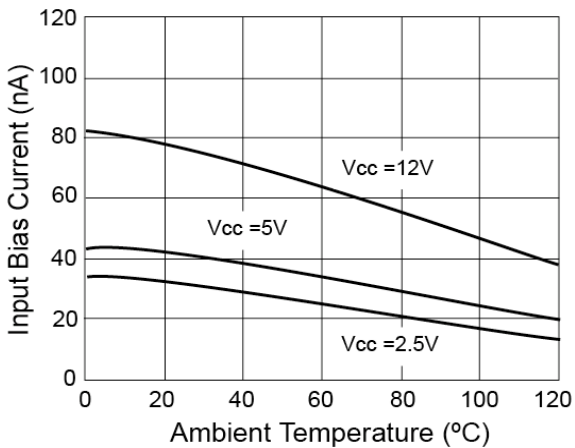

FIGURE 4 – Ictrl Input Bias Current vs. Ambient Temperature

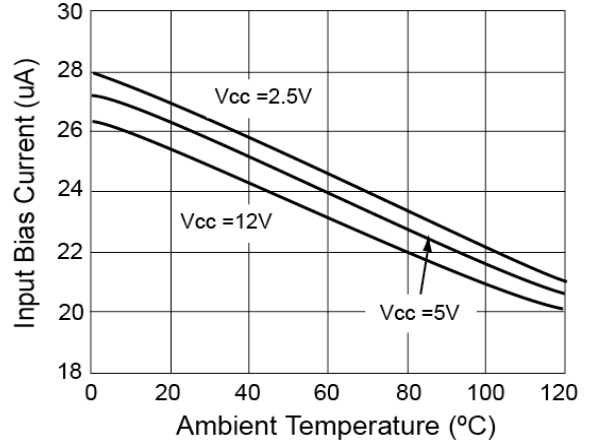

FIGURE 5 – Output Short Circuit Current vs. Ambient Temperature

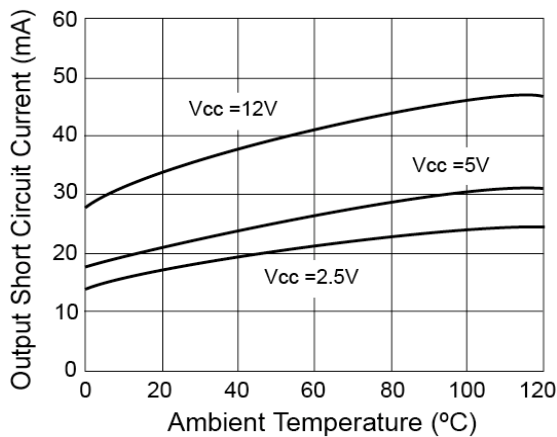
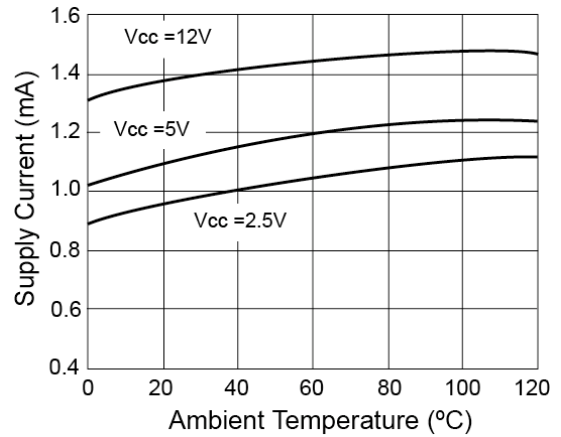
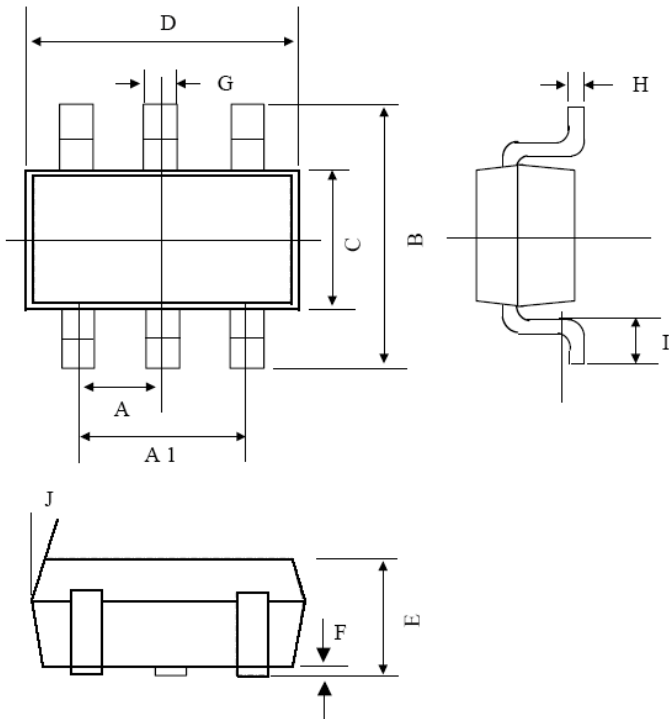

FIGURE 6 – Supply Current vs. Ambient Temperature



SOT-26 Mechanical Drawing



SOT-26 DIMENSION						
DIM	MILLIMETERS			INCHES		
	MIN	TYP	MAX	MIN	TYP	MAX
A	0.95 BSC			0.0374 BSC		
A1	1.9 BSC			0.0748 BSC		
B	2.60	2.80	3.00	0.1024	0.1102	0.1181
C	1.40	1.50	1.70	0.0551	0.0591	0.0669
D	2.80	2.90	3.10	0.1101	0.1142	0.1220
E	1.00	1.10	1.20	0.0394	0.0433	0.0472
F	0.00	--	0.10	0.00		0.0039
G	0.35	0.40	0.50	0.0138	0.0157	0.0197
H	0.10	0.15	0.20	0.0039	0.0059	0.0079
I	0.30	--	0.60	0.0118	--	0.0236
J	5°	--	10°	5°	--	10°

Marking Diagram

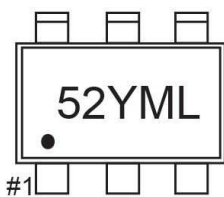

- 52** = Device Code
- Y** = Year Code
- M** = Month Code for Halogen Free Product
(**O**=Jan, **P**=Feb, **Q**=Mar, **R**=Apr, **S**=May, **T**=Jun, **U**=Jul, **V**=Aug, **W**=Sep, **X**=Oct, **Y**=Nov, **Z**=Dec)
- L** = Lot Code

Constant Voltage and Constant Current Controller For Battery Chargers and Adaptors

Notice

Specifications of the products displayed herein are subject to change without notice. TSC or anyone on its behalf, assumes no responsibility or liability for any errors or inaccuracies.

Information contained herein is intended to provide a product description only. No license, express or implied, to any intellectual property rights is granted by this document. Except as provided in TSC's terms and conditions of sale for such products, TSC assumes no liability whatsoever, and disclaims any express or implied warranty, relating to sale and/or use of TSC products including liability or warranties relating to fitness for a particular purpose, merchantability, or infringement of any patent, copyright, or other intellectual property right.

The products shown herein are not designed for use in medical, life-saving, or life-sustaining applications. Customers using or selling these products for use in such applications do so at their own risk and agree to fully indemnify TSC for any damages resulting from such improper use or sale.

www.s-manuals.com