

ZR431L

Adjustable precision shunt regulator

Summary

Description

The ZR431L is a three terminal adjustable shunt regulator offering excellent temperature stability and output current handling capability up to 25mA. The output voltage may be set to any chosen voltage between 1.24 and 10 volts by selection of two external divider resistors.

The devices can be used as a replacement for zener diodes in many applications requiring an improvement in zener performance.

The ZR431L is particularly used in the feedback control loop of switch mode power supplies. In this application the device 1.24 volt reference enables the generation of low voltage supplies, typically 3.3 volts or 3 volts.



Features

- 2.5% and 1% tolerance
- Max. temperature coefficient 50 ppm/°C
- Temperature compensated for operation over -40 to 85°C
- 100mA to 25mA current sink capability
- Surface mount SOT23 package

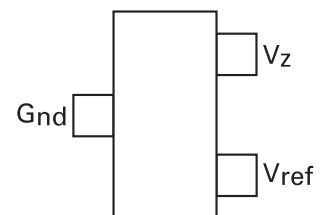

Applications

- Switch mode power supplies
- Shunt regulator
- Series regulator
- Voltage monitor
- Over voltage / under voltage protection

Ordering information

Device	Pack	Part mark	Status	Quantity per reel	Reel size (inches)	TOL %
ZR431LF01TA	SOT23	43M	Active	3000	7	1
ZR431LF02TA	SOT23	43L	Active	3000	7	2.5
ZR431LC01STOB	TO92	ZR431L01	Obsolete	1500		1
ZR431LC02STOB	TO92	ZR431L02	Obsolete	1500		2.5
ZR431LC01L	TO92	ZR431L01	Obsolete		Loose	1
ZR431LC02L	TO92	ZR431L02	Obsolete		Loose	2.5

ZR431L

Absolute maximum ratings

Parameter	Symbol	Limit	Unit
Cathode voltage	V_Z	10	V
Cathode current		50	mA
Storage temperature	T_{STG}	-55 to 105	°C
Junction temperature	T_J	-40 to 125	°C

Power dissipation (at $T_{amb} = 25^\circ\text{C}$ unless otherwise stated)

Package	Value	Unit
SOT23	330	mW

Recommended operating conditions

Parameter	Min.	Max.
Cathode voltage	V_{REF}	10V
Cathode current	100 μA	25mA
Operating temperature	-40°C	85°C

Block diagram

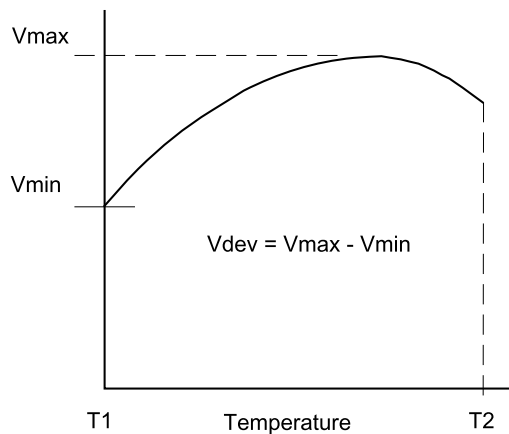
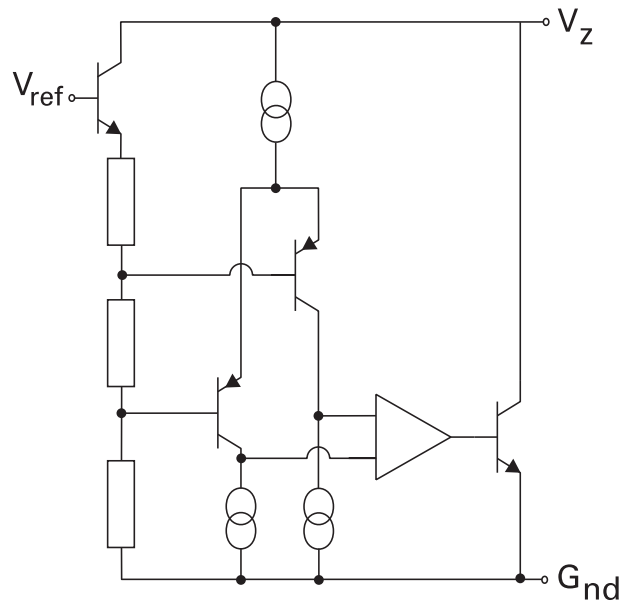

Deviation of reference input voltage, V_{dev} , is defined as the maximum variation of the reference input voltage over the full temperature range.

The average temperature coefficient of the reference input voltage, V_{ref} is defined as:

$$V_{ref}(ppm/^\circ C) = \frac{V_{dev} \times 1000000}{V_{ref}(T1 - T2)}$$

The dynamic output impedance, R_z , is defined as:

$$R_z = \frac{\Delta V_z}{\Delta I_z}$$

When the device is programmed with two external resistors, $R1$ and $R2$, (fig 2), the dynamic output impedance of the overall circuit, R' , is defined as:

$$R' = R_z \left(1 + \frac{R1}{R2} \right)$$

Electrical characteristics (at $T_{amb} = 25^{\circ}\text{C}$ unless otherwise stated)

Parameter	Symbol	Min.	Typ.	Max.	Unit	Conditions
Reference Voltage	V_{ref} V_{ref}	1.209 1.228	1.24 1.24	1.271 1.252	V V	$I_L = 10\text{mA}$ (Fig1), $V_Z = V_{ref}$
Deviation of Reference Input Voltage over Temperature	V_{dev}		4.0	8.0	mV	$I_L = 10\text{mA}$, $V_Z = V_{ref}$ $T_a = \text{full range}$ (Fig 1)
Ratio of the change in Reference Voltage to the change in Cathode Voltage)	$\frac{\Delta V_{ref}}{\Delta V_Z}$		0.5	2.0	mV/V	V_Z from V_{ref} to 10V $I_Z = 10\text{mA}$ (Fig2)
Reference Input Current	I_{ref}	0.02	0.11	0.4	μA	$R1 = 10\text{k}$, $R2 = \text{O/C}$, $I_L = 10\text{mA}$ (fig2)
Deviation of Reference Input Current over Temperature	ΔI_{ref}		0.02	0.2	μA	$R1 = 10\text{k}$, $R2 = \text{O/C}$, $I_L = 10\text{mA}$ $T_a = \text{full range}$ (Fig2)
Minimum Cathode Current for Regulation	I_{Zmin}		30	100	μA	
Off-state Current	I_{Zoff}		10	30	μA	$V_Z = 10\text{V}$, $V_{ref} = 0\text{V}$ (Fig3)
Dynamic Output Impedance	R_Z		0.25	2	Ω	$V_Z = V_{ref}$ (Fig1), $f = 0\text{Hz}$, $I_L = 10\text{mA}$

DC Test circuits

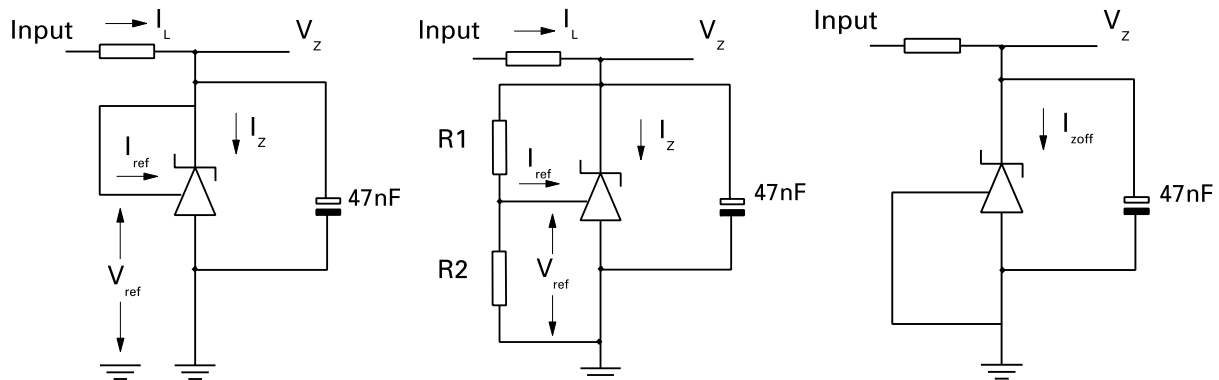
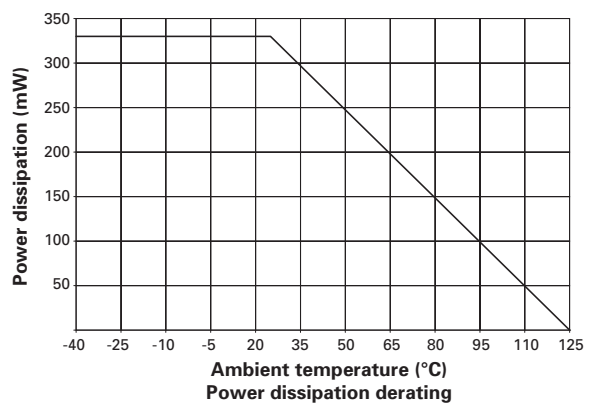
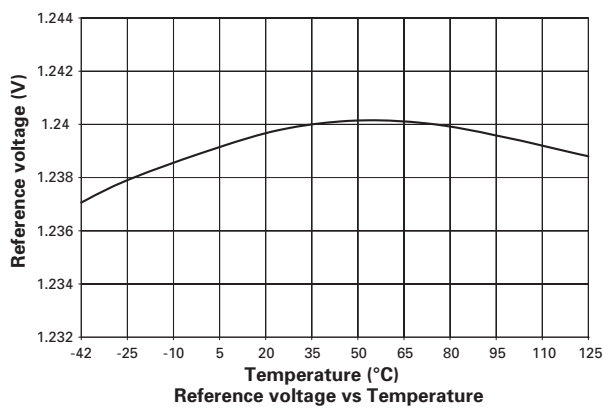
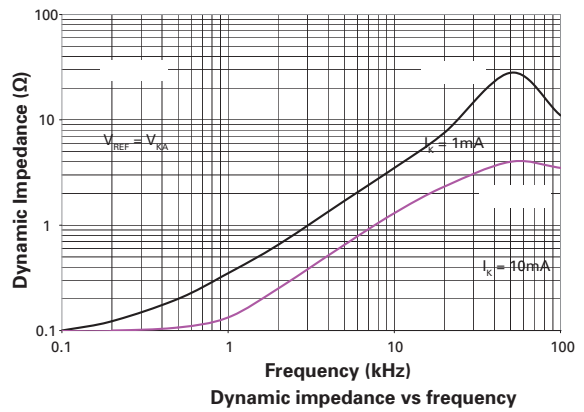
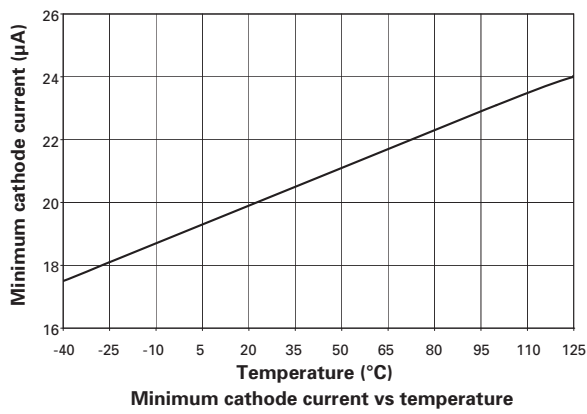
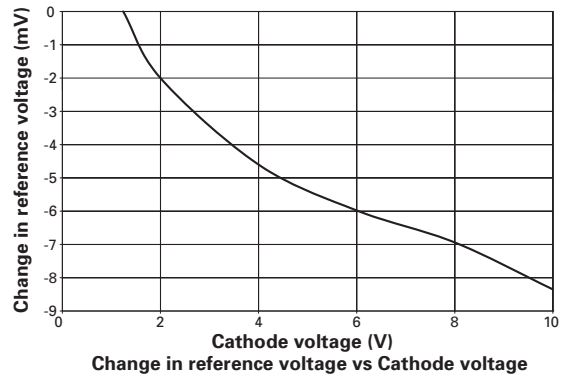
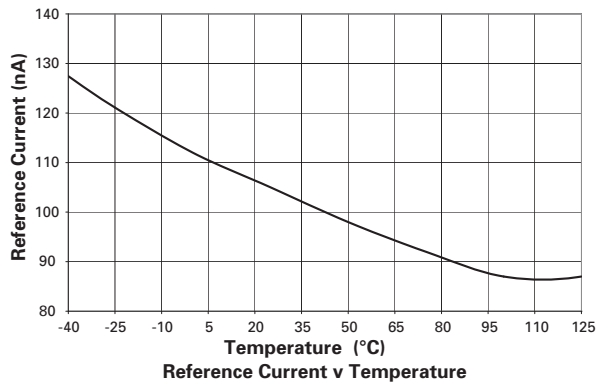
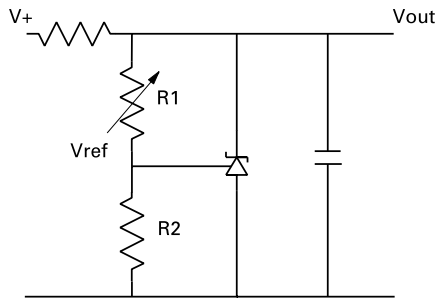

Fig 1 - Test Circuit for $V_Z = V_{ref}$ Fig 2 - Test Circuit for $V_Z > V_{ref}$ Fig 3 - Test Circuit for Off State current

Typical characteristics



Application circuits



$$V_{out} = \left(1 + \frac{R1}{R2}\right) V_{ref}$$

SHUNT REGULATOR

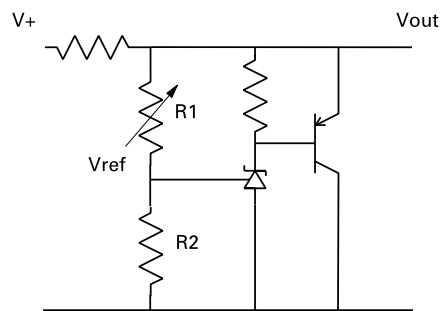

$$V_{out} = \left(1 + \frac{R1}{R2}\right) V_{ref}$$

HIGHER CURRENT SHUNT REGULATOR

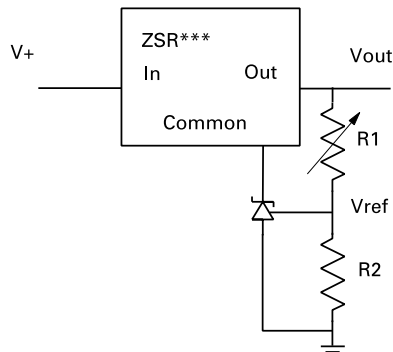

$$V_{out_MIN} = V_{ref} + V_{reg}$$

$$V_{out} = \left(1 + \frac{R1}{R2}\right) V_{ref}$$

OUTPUT CONTROL OF A THREE TERMINAL FIXED REGULATOR

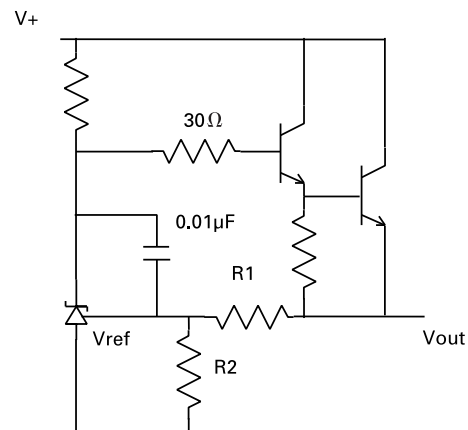

$$V_{out} = \left(1 + \frac{R1}{R2}\right) V_{ref}$$

SERIES REGULATOR

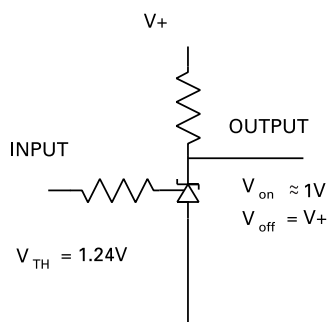

SINGLE SUPPLY COMPARATOR WITH TEMPERATURE COMPENSATED THRESHOLD

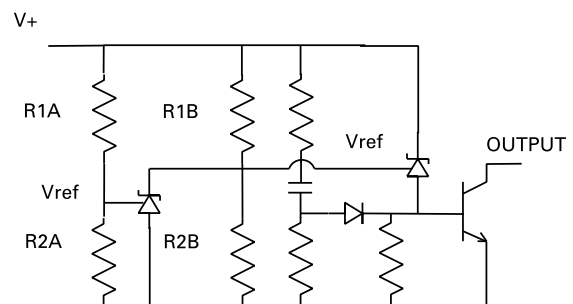

$$\text{Low limit} = \left(1 + \frac{R1B}{R2B}\right) V_{ref}$$

$$\text{High limit} = \left(1 + \frac{R1A}{R2A}\right) V_{ref}$$

OVER VOLTAGE / UNDER VOLTAGE PROTECTION CIRCUIT

Typical characteristics

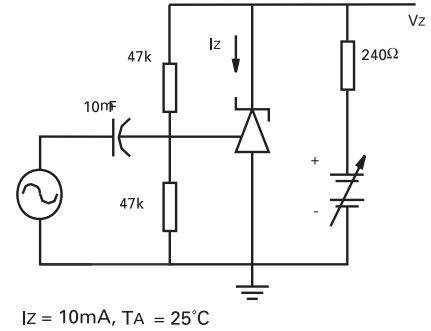
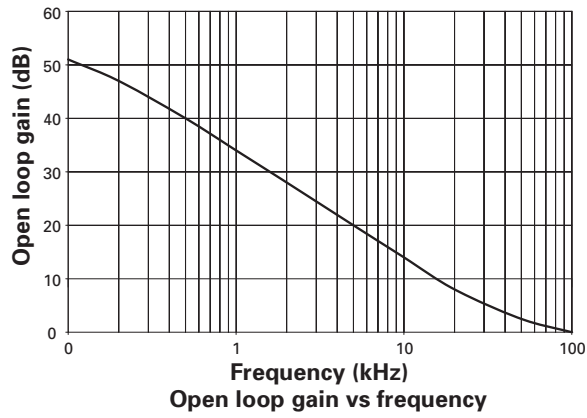

Test Circuit for Open Loop Voltage Gain

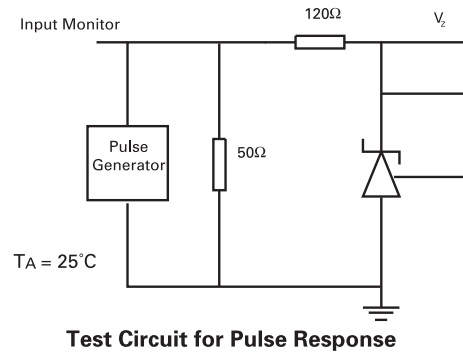
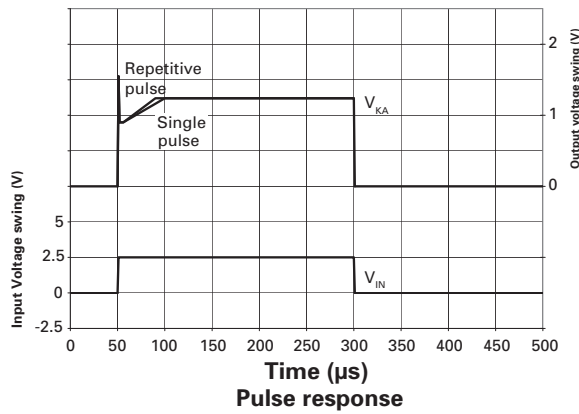

Test Circuit for Pulse Response

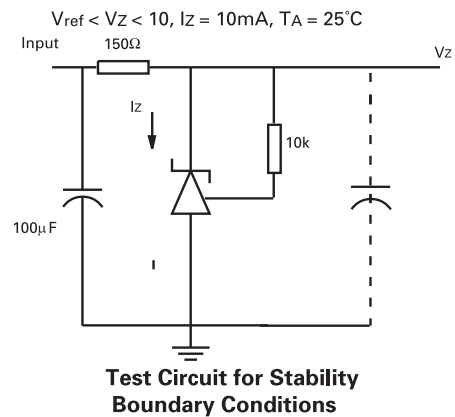
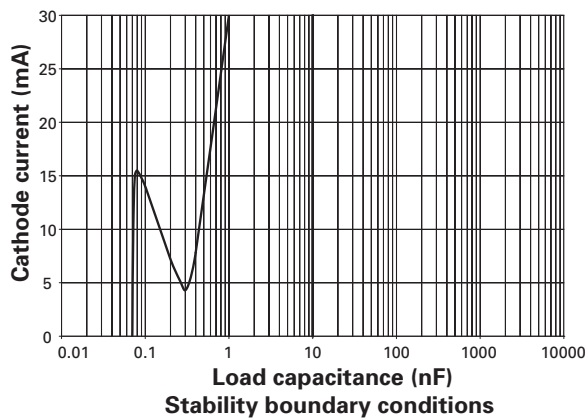

Test Circuit for Stability Boundary Conditions

SOT23 Package outline and pad layout details

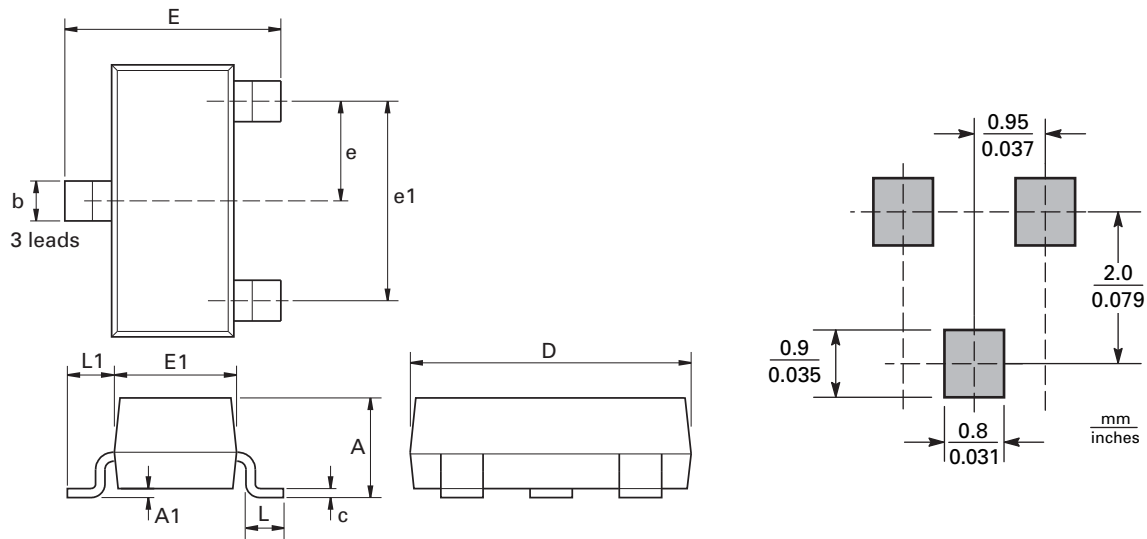

Dim.	Millimeters		Inches		Dim.	Millimeters		Inches	
	Min.	Max.	Min.	Max.		Min.	Max.	Min.	Max.
A	-	1.12	-	0.044	e1	1.90 NOM		0.075 NOM	
A1	0.01	0.10	0.0004	0.004	E	2.10	2.64	0.083	0.104
b	0.30	0.50	0.012	0.020	E1	1.20	1.40	0.047	0.055
c	0.085	0.20	0.003	0.008	L	0.25	0.60	0.0098	0.0236
D	2.80	3.04	0.110	0.120	L1	0.45	0.62	0.018	0.024
e	0.95 NOM		0.037 NOM		-	-	-	-	-

Note: Controlling dimensions are in millimeters. Approximate dimensions are provided in inches.

TO92 Package outline

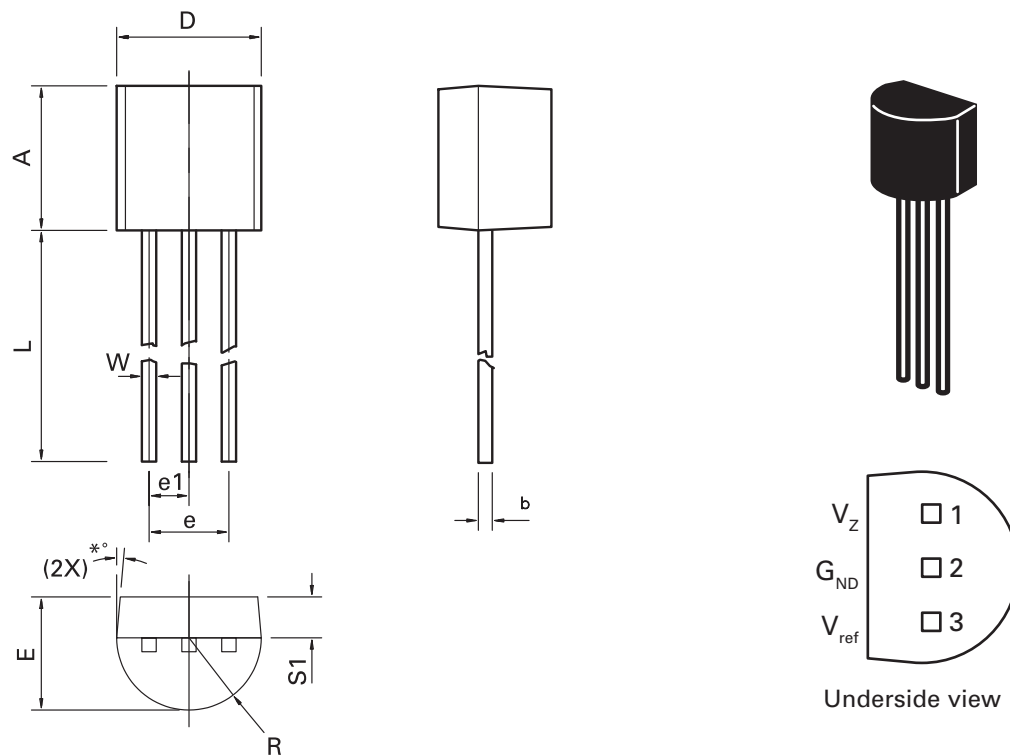

Dim.	Millimeters		Inches	
	Min.	Max.	Min.	Max.
A	4.32	4.95	0.170	0.195
b	0.36	0.51	0.014	0.020
E	3.30	3.94	0.130	0.155
e	2.41	2.67	0.095	0.105
e1	1.14	1.40	0.045	0.055
L	12.70	15.49	0.500	0.610
R	2.16	2.41	0.085	0.095
S1	1.14	1.52	0.045	0.060
W	0.41	0.56	0.016	0.022
D	4.45	4.95	0.175	0.195
*°	4°	6°	4°	6°

Note: Controlling dimensions are in millimeters. Approximate dimensions are provided in inches

Definitions

Product change

Zetex Semiconductors reserves the right to alter, without notice, specifications, design, price or conditions of supply of any product or service. Customers are solely responsible for obtaining the latest relevant information before placing orders.

Applications disclaimer

The circuits in this design/application note are offered as design ideas. It is the responsibility of the user to ensure that the circuit is fit for the user's application and meets with the user's requirements. No representation or warranty is given and no liability whatsoever is assumed by Zetex with respect to the accuracy or use of such information, or infringement of patents or other intellectual property rights arising from such use or otherwise. Zetex does not assume any legal responsibility or will not be held legally liable (whether in contract, tort (including negligence), breach of statutory duty, restriction or otherwise) for any damages, loss of profit, business, contract, opportunity or consequential loss in the use of these circuit applications, under any circumstances.

Life support

Zetex products are specifically not authorized for use as critical components in life support devices or systems without the express written approval of the Chief Executive Officer of Zetex Semiconductors plc. As used herein:

A. Life support devices or systems are devices or systems which:

1. are intended to implant into the body

or

2. support or sustain life and whose failure to perform when properly used in accordance with instructions for use provided in the labeling can be reasonably expected to result in significant injury to the user.

B. A critical component is any component in a life support device or system whose failure to perform can be reasonably expected to cause the failure of the life support device or to affect its safety or effectiveness.

Reproduction

The product specifications contained in this publication are issued to provide outline information only which (unless agreed by the company in writing) may not be used, applied or reproduced for any purpose or form part of any order or contract or be regarded as a representation relating to the products or services concerned.

Terms and Conditions

All products are sold subjects to Zetex' terms and conditions of sale, and this disclaimer (save in the event of a conflict between the two when the terms of the contract shall prevail) according to region, supplied at the time of order acknowledgement.

For the latest information on technology, delivery terms and conditions and prices, please contact your nearest Zetex sales office.

Quality of product

Zetex is an ISO 9001 and TS16949 certified semiconductor manufacturer.

To ensure quality of service and products we strongly advise the purchase of parts directly from Zetex Semiconductors or one of our regionally authorized distributors. For a complete listing of authorized distributors please visit: www.zetex.com/salesnetwork

Zetex Semiconductors does not warrant or accept any liability whatsoever in respect of any parts purchased through unauthorized sales channels.

ESD (Electrostatic discharge)

Semiconductor devices are susceptible to damage by ESD. Suitable precautions should be taken when handling and transporting devices. The possible damage to devices depends on the circumstances of the handling and transporting, and the nature of the device. The extent of damage can vary from immediate functional or parametric malfunction to degradation of function or performance in use over time. Devices suspected of being affected should be replaced.

Green compliance

Zetex Semiconductors is committed to environmental excellence in all aspects of its operations which includes meeting or exceeding regulatory requirements with respect to the use of hazardous substances. Numerous successful programs have been implemented to reduce the use of hazardous substances and/or emissions.

All Zetex components are compliant with the RoHS directive, and through this it is supporting its customers in their compliance with WEEE and ELV directives.

Product status key:

"Preview"	Future device intended for production at some point. Samples may be available
"Active"	Product status recommended for new designs
"Last time buy (LTB)"	Device will be discontinued and last time buy period and delivery is in effect
"Not recommended for new designs"	Device is still in production to support existing designs and production
"Obsolete"	Production has been discontinued

Datasheet status key:

"Draft version"	This term denotes a very early datasheet version and contains highly provisional information, which may change in any manner without notice.
"Provisional version"	This term denotes a pre-release datasheet. It provides a clear indication of anticipated performance. However, changes to the test conditions and specifications may occur, at any time and without notice.
"Issue"	This term denotes an issued datasheet containing finalized specifications. However, changes to specifications may occur, at any time and without notice.

Zetex sales offices

Europe	Americas	Asia Pacific	Corporate Headquarters
Zetex GmbH Kustermann-park Balanstraße 59 D-81541 München Germany Telephone: (49) 89 45 49 49 0 Fax: (49) 89 45 49 49 49 europe.sales@zetex.com	Zetex Inc 700 Veterans Memorial Highway Hauppauge, NY 11788 USA Telephone: (1) 631 360 2222 Fax: (1) 631 360 8222 usa.sales@zetex.com	Zetex (Asia Ltd) 3701-04 Metroplaza Tower 1 Hing Fong Road, Kwai Fong Hong Kong Telephone: (852) 26100 611 Fax: (852) 24250 494 asia.sales@zetex.com	Zetex Semiconductors plc Zetex Technology Park, Chadderton Oldham, OL9 9LL United Kingdom Telephone: (44) 161 622 4444 Fax: (44) 161 622 4446 hq@zetex.com

© 2008 Published by Zetex Semiconductors plc

www.s-manuals.com