

MPS[®]

Offline 600W Battery Charger
PFC + LLC with HR1211

Table of Contents

1	Overview.....	3
1.1	Description.....	3
1.2	Features	3
1.3	Applications	3
2	System Definition.....	4
2.1	Block Diagram	4
2.2	Related Solutions	4
2.3	System Specifications	4
3	Design	5
3.1	HR1211: PFC + LLC Combo Controller	5
3.2	MP6925A: Synchronous Rectifier Controller	5
3.3	HF500-15: Flyback Controller.....	5
3.4	MP2009: LDO 3V3	5
3.5	PFC Converter Stage	5
3.6	LLC Converter Stage.....	6
3.7	Schematics	7
3.8	Bill of Materials	10
3.9	Inductive Components.....	14
3.10	Mechanical Components	18
3.11	PCB Layout Guidelines	19
4	Hardware Start-Up Procedure	22
4.1	Test Equipment	22
4.2	System Power-Up.....	23
4.3	Signal Measurements.....	23
5	Test Results.....	24
5.1	Test Overview.....	24
5.2	Waveforms	27
5.3	Thermal Measurements.....	30
5.4	Conducted Emissions.....	31
6	Disclaimer	32

1 Overview

1.1 Description

The EVHR1211-Y-00B is an evaluation board for lithium-ion batteries, which are typically used in e-mobility and uninterruptible power supply (UPS) applications. The EVB can also be used as a general power supply unit. The device regulates the output voltage to 58.8V if there is not a battery present. This solution is based on a PFC + LLC combo controller from a single integrated circuit (the HR1211).

Instead of using costly, low-frequency filters, the EVHR1211-Y-00B offers excellent power factor levels with active power factor correction (PFC). The design shows high power density with low overall cost. In the place of diodes, synchronous rectification (SR) reduces the voltage drop, and constant current (CC) and constant voltage (CV) control ensures the battery is charged properly.

Lithium-ion batteries generally require a battery management system (BMS) to ensure that the battery operates within safe parameters. This charger can interact with a BMS through a relay signal. This helps prevent high-current spikes in the output connection, which can trigger BMS protections.

Electromagnetic compatibility (EMC) tests, harmonic emission tests, and no-load consumption tests were utilized to ensure that this solution meets industry standards.

1.2 Features

- Wide 85V to 265V Operating Input Range
- 14S Battery Configuration (3.6V)
- High Efficiency Up to 92%
- Meets EuP Lot 6 and COC Version 5 Tier 2 Specifications
- Meets Class A IEC61000-3-2 Standards
- Meets EN55032 Class B Standards
- High Power Factor (PF)
- Overload Protection (Auto-Restart Mode)
- Short-Circuit Protection (SCP) (Auto-Restart Mode)
- Over-Voltage Protection (OVP)
- Anti-Capacitive Mode Protection
- Form Factor: 190mmx100mmx50mm (3U Rack STD)



Figure 1: EVHR1211-Y-00B Top View

1.3 Applications

- E-Bike Battery Chargers
- Rack UPS

All MPS parts are lead-free and adhere to the RoHS directive. For MPS green status, please visit the MPS website under Quality Assurance. "MPS", the MPS logo, and "Simple, Easy Solutions" are registered trademarks of Monolithic Power Systems, Inc. or its subsidiaries.



Warning: Although this board is designed to satisfy safety requirements, the engineering prototype has not been agency approved. Therefore, all testing should be performed using an isolation transformer to provide the AC input to the prototype board.

2 System Definition

2.1 Block Diagram

Figure 2 shows the evaluation board's system block, as well as how the evaluation board interacts with each MPS IC.

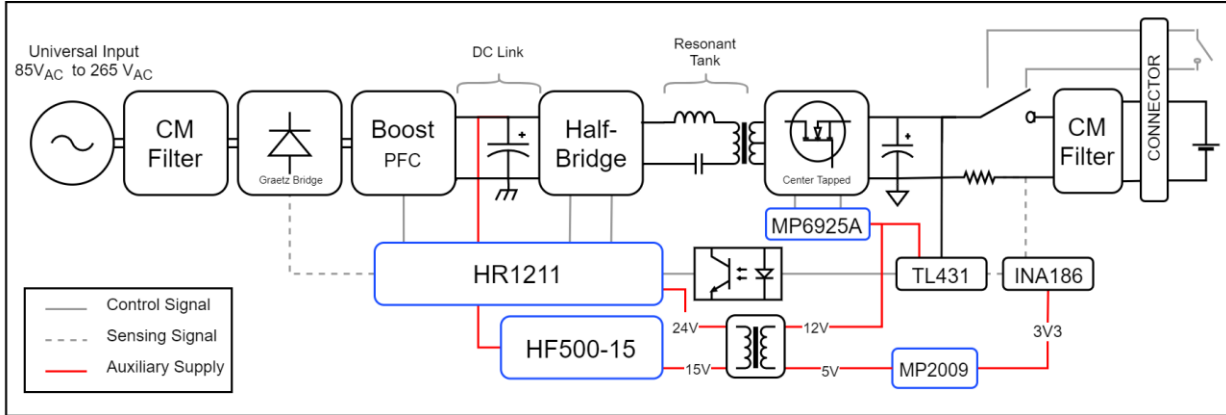

Figure 2: Block Diagram

2.2 Related Solutions

This reference design is based on the following MPS solutions:

Table 1: System Integrated Circuits

MPS Integrated Circuit	Description
HR1211	High-performance digital PFC + LLC combo controller
HF500-15	Fixed-frequency flyback regulator
MP6925A	Synchronous rectifier (SR) controller
MP2009	Low-dropout (LDO) voltage regulator

2.3 System Specifications

Table 2: System Specifications

Parameter	Specifications
Input voltage range	85V _{AC} to 265V _{AC}
Output voltage range	35V _{DC} to 58.8V _{DC} ($\pm 1.5\%$)
Output current	10A ($\pm 1.5\%$)
Nominal conditions	Input: 230V _{AC} , output: 50.4V _{DC} /10A (14S Li-ion STD)
Board form factor	220mmx100mmx50mm
Efficiency	>92%
Standby power consumption	Meets EuP Lot 4 and COC Version 5 Tier 2 (<500mW at 265V) standards
Conducted emissions	Meets Class B EN55032 standards
Output voltage ripple	$\pm 100\text{mV}$ at full load
Output current ripple	$\pm 485\text{mA}$ at full load

3 Design

3.1 HR1211 (PFC + LLC Combo Controller)

The HR1211 controller combines a multi-mode PFC and a current mode half-bridge LLC in a single 20-pin device. The HR1211 includes all the required peripheral circuitry (e.g. current amplifiers, comparators, and drivers for the PFC and LLC MOSFETs) to control both topologies. The IC can be configured via the UART interface. These features make the HR1211 well-suited for compact, cost-effective solutions.

The PFC controller can work in continuous conduction mode (CCM) under heavy-load conditions, or it can work in discontinuous conduction mode (DCM) under light-load conditions. The converter can be configured to reduce no-load consumption while the device works in burst mode. In this scenario, the PFC turns on for a few milliseconds, then switches off for several grid cycles. This maintains the bus voltage and reduces commutation losses.

The LLC controller uses a current control strategy to improve the converter stability and its transient response. Under heavy loads, the controller remains in a steady state and with adaptive dead time adjustment (ADTA) to ensure zero-voltage switching (ZVS). Under light-load conditions, the controller enters skip mode, and an idle time is introduced between the configurable switching cycles. This function reduces the average switching frequency, which consequently minimizes the magnetic losses in the inductive components. The last switching strategy is burst mode. In burst mode, the idle time increases, which drastically reduces the load. This also reduces converter losses while keeping the output voltage within the hysteresis levels.

These types of controllers offer several protections to ensure that the device operates within a safe region. The HR1211 protection features include thermal shutdown, bus over-voltage protection (OVP), over-current limiting for either the PFC or LLC, open-loop protection, and over-power protection.

3.2 MP6925A (Synchronous Rectifier Controller)

The MP6925A is a dual-LLC, fast turn-off, intelligent rectifier for synchronous rectification in LLC resonant converters. The IC drives two N-channel MOSFETs, and regulates their forward voltage drop to about 45mV. To ensure zero energy return, the controller turns off the MOSFETs before the current goes negative. The MP6925A has a light-load function to latch off the gate driver under light-load conditions, limiting the current consumption to 175 μ A. In this scenario, the current flows through the parasitic diodes of the MOSFET devices.

3.3 HF500-15 (Flyback Controller)

The HF500-15 is a flyback controller with an integrated 700V MOSFET. This device also has three operating conditions based on the load. Under heavy loads, the controller operates in the first mode with a fixed frequency. In this mode, dithering modulation is added to spread the switching harmonics in the conducted electromagnetic tests. Under light loads, there is a second mode with a fixed current peak, which reduces the switching frequency to minimize the switching losses. When the load is drastically reduced, the controller operates in burst mode.

3.4 MP2009 (LDO 3V3)

The MP2009 is an ultra-low noise, low-dropout (LDO) regulator based on a PMOS device. It has a no-load consumption of about 50 μ A, with low in/out capacity for stable operation.

3.5 PFC Converter Stage

The PFC topology is used for two purposes. The first is to step up the input voltage, and regulate it against load/line perturbations. The second is to shape the input current in a sinusoidal form that is in phase with the input voltage. The key element of this stage is the inductor design.

A smaller-value inductor results in high current ripples, which forces the system to work in DCM with minimal switching losses but bigger filter components. A larger-value inductor results in greater switching losses. This system's compact design requires a larger-value inductor to reduce the Pi filter stage (see Table 3).

Table 3: PFC Stage Specifications

Parameter	Specification
Input voltage range	85V _{AC} to 265V _{AC}
Output voltage range	400V _{DC} (±5%)
Output current	1.7A ±1.5%
Nominal conditions	Input: 230V _{AC} (high line) or 120V _{AC} (low line), output: 400V _{DC} /1.7A
Efficiency	>95% with 230V _{AC}
Power factor	>98%, full load for the entire input voltage range
Inductor	338μH
BUS capacitor	330μF, 450V
Switching frequency	100kHz
Output voltage ripple	<±10V at full loads

Figure 3 shows the low-line inductor current. Figure 4 shows the high-line inductor current.

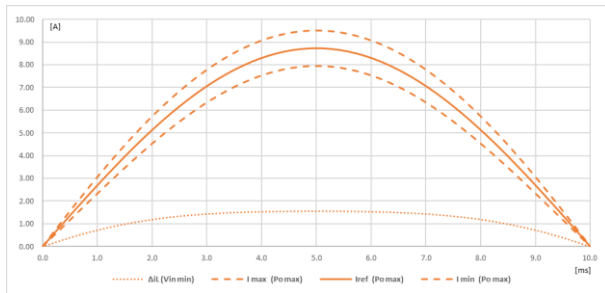

Figure 3: Low-Line Inductor Current

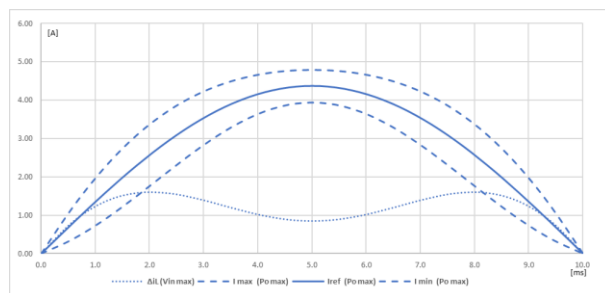

Figure 4: High-Line Inductor Current

3.6 LLC Converter Stage

LLC topology is used due to its soft switching properties. In this case, as a battery charger, the output voltage range is wide compared to a regular power supply unit (PSU). However, this topology is dependent on the voltage gain and switching frequency. Solve this issue by balancing the quality factor of the resonant filter with the value of the reactive components. Low-quality factor filters lead to wide frequency variations when adjusting the output voltage, causing poor transient response and EMI performance. Larger-value filter components lead to high currents through the resonant tank, causing unnecessary copper and magnetic losses (see Table 4).

Table 4: System Specifications

Parameter	Specification
Input voltage range	370V to 410V
Output voltage range	35V _{DC} to 58.8V _{DC} (±1.5%)
Output current	10A (±1.5%)
Nominal conditions	Input: 400V, output: 50.4V _{DC} /10A (14S Li-ion STD)
Efficiency	>95%
Resonant inductor (L _R)	90μH
Resonant capacitor (C _R)	40.8nF
Magnetizing inductance (L _M)	144μH
Switching frequency range	80kHz to 100kHz, 145kHz at start-up
Output voltage ripple	<±100mV at full loads
Output current ripple	<±0.5A at full loads

Figure 5 shows the regular PSU LLC tank gain. Figure 6 shows the actual battery charger design.

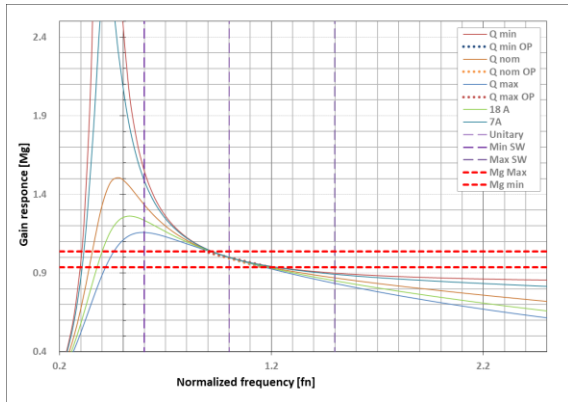

Figure 5: Regular PSU LLC Tank Gain

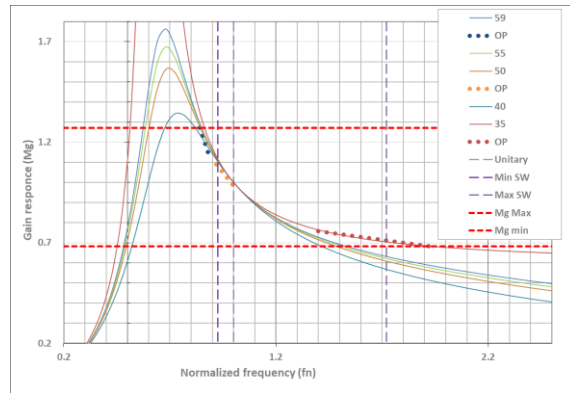

Figure 6: Actual Battery Charger Design

3.7 Schematics

Figure 7 shows the power factor correction (PFC) stage (AC/DC).

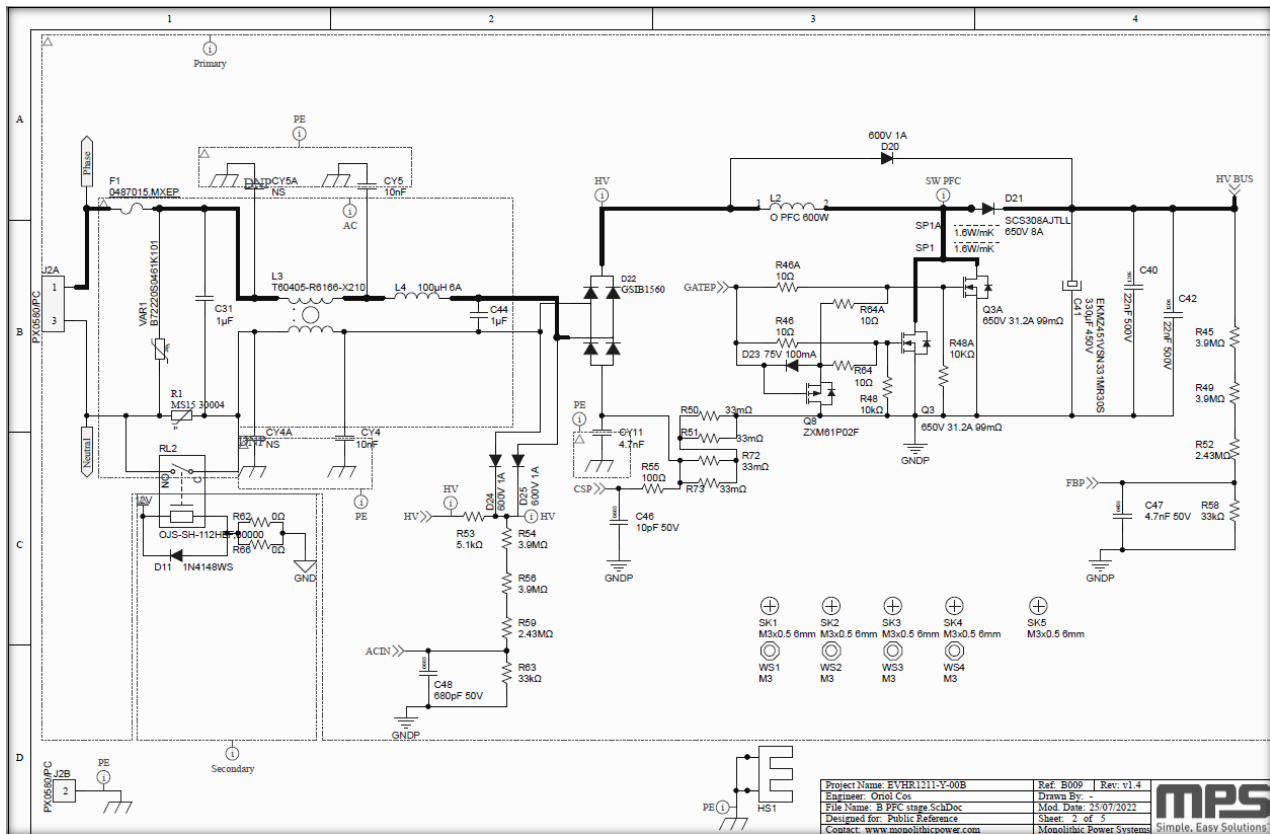

Figure 7: PFC Stage

Figure 8 on page 8 shows the resonant converter stage (DC/DC), constant current and constant voltage control, and synchronous rectification (LLC stage).

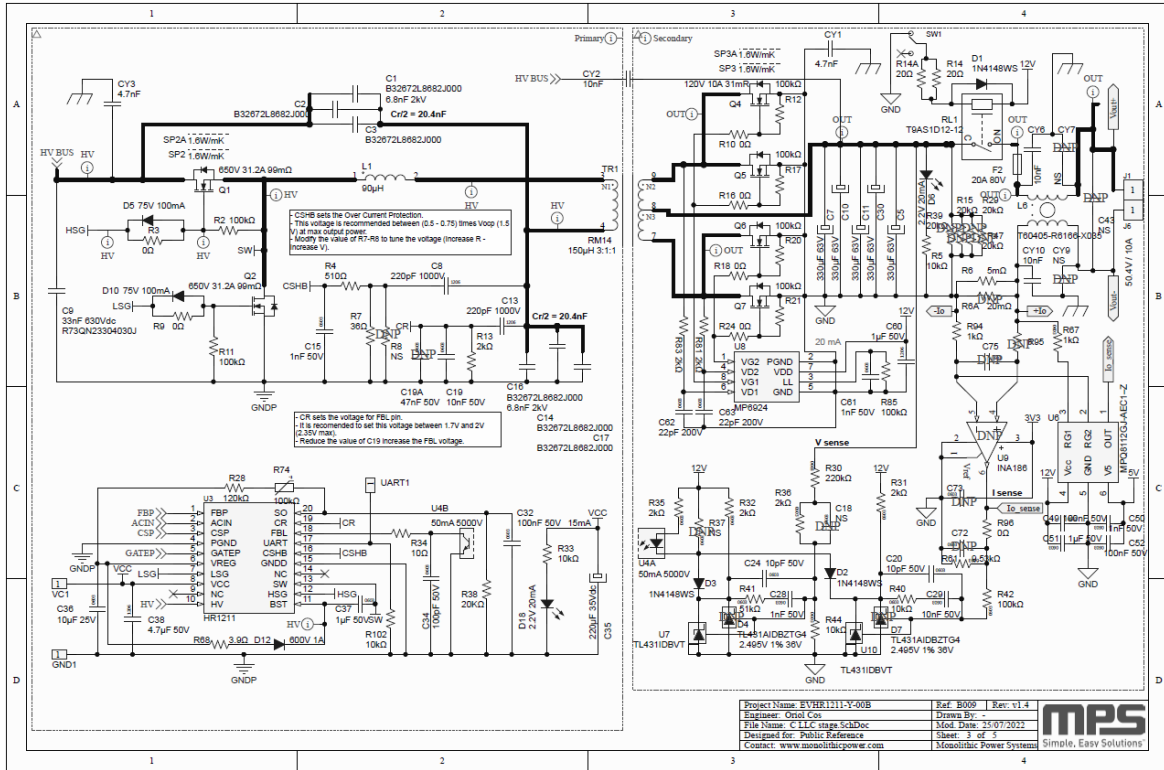

Figure 8: LLC Stage (CC and CV) and SR

Figure 9 shows the auxiliary supply system (flyback).

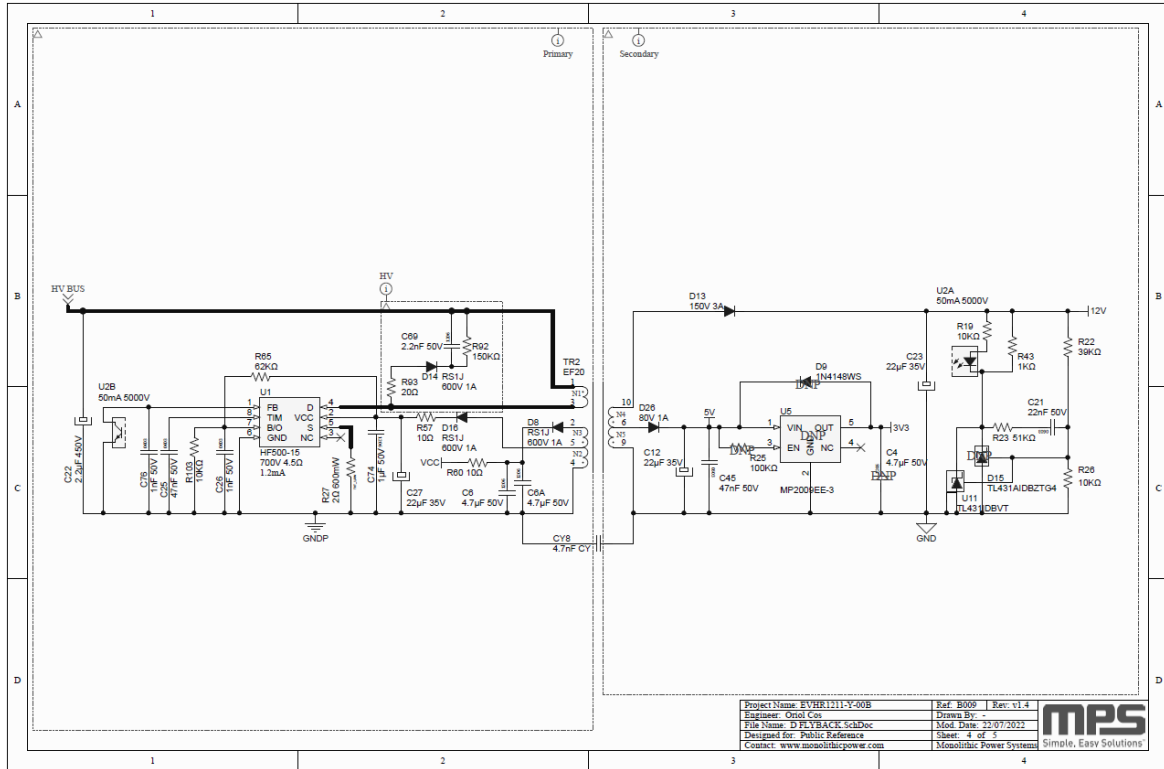

Figure 9: Auxiliary Supply

Figure 10 shows an alternative current sensing, fans and alternative connector (H15).

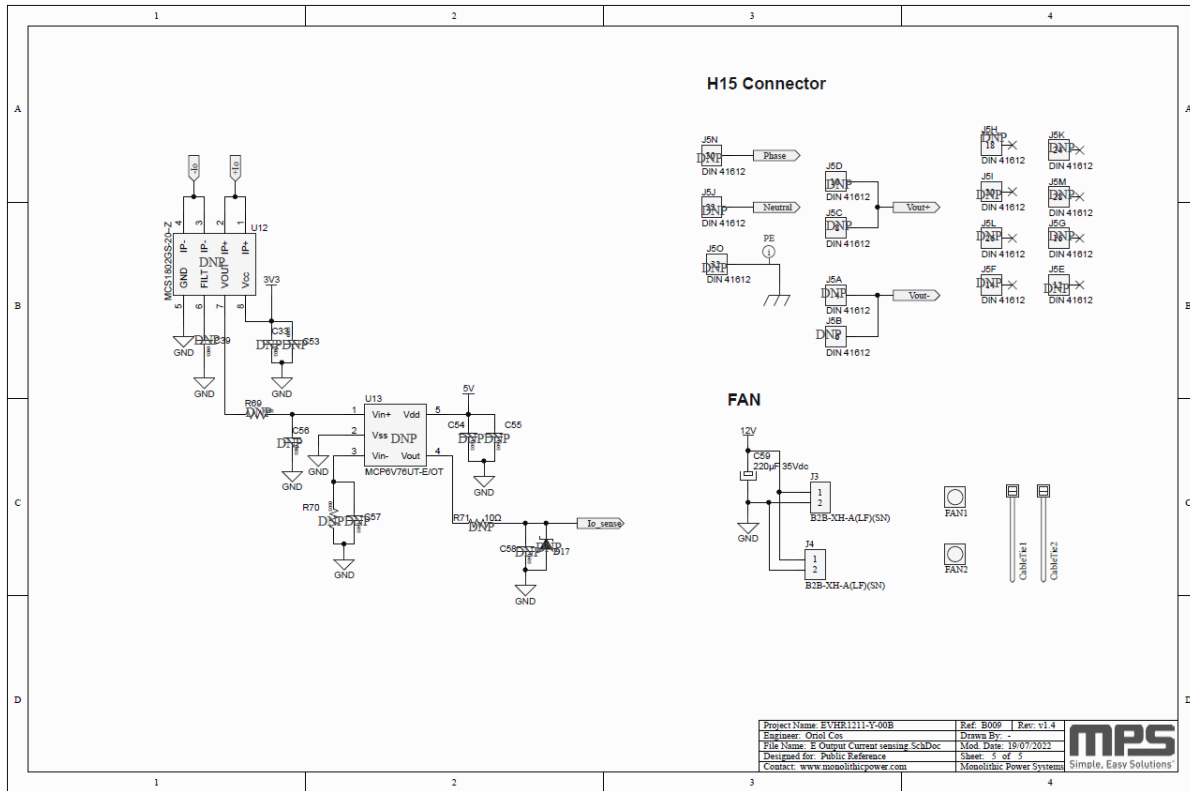

Figure 10: Fans (Current-Sensing and Connector Options)

3.8 Bill of Materials

Qty	Ref	Value	Description	Package	Manufacturer	Manufacturer PN
6	C1, C2, C3, C14, C16, C17	6.8nF	Film capacitor, 2kV	r15mm (18mmx6mm)	TDK	B32672L8682J000
3	C12, C23, C27	22 μ F	Electrolytic capacitor, 35V	r2.54mm, d6.3mm	Chemi-Con	EFL-350ELL220MF07D
5	C15, C26, C28, C61, C76	1nF	MLCC capacitor, 50V	0603	Kemet	C0603X102K5RAC3316
2	C19, C29	10nF	MLCC capacitor, 50V	0603	AVX	06035C103JAT2A
2	C25, C45	47nF	MLCC capacitor, 50V	0603	Kemet	C0603C473K5RACTU
3	C20, C24, C46	10pF	MLCC capacitor, 50V	0603	AVX	06035A100JAT2A
1	C21	22nF	MLCC capacitor, 50V	0603	Kemet	C0603C223K5RACAUTO
1	C22	2.2 μ F	Electrolytic capacitor, 450V	r3.5mm, d8mm	Chemi-Con	ESMQ451ELL2R2MHB5D
2	C31, C44	1 μ F	Film capacitor, 350V _{AC}	r27.5mm	Kemet	F861BZ105M310A
3	C32, C49, C52	100nF	MLCC capacitor, 50V	0603	Kemet	C0603X104K5RAC3316
1	C34	100pF	MLCC capacitor, 50V	0603	AVX	06035A101JAT2A
2	C35, C59	220 μ F	Electrolytic capacitor, 35V _{DC}	r3.5mm, d8mm	Rubycon	35ZL220MEFC8X16
1	C36	10 μ F	MLCC capacitor, 25V	0603	TDK	C1608X5R1E106M080AC
2	C37, C51	1 μ F	MLCC capacitor, 50V	0603	Tayo Yuden	UMK107BJ105KA-T
3	C6, C6A, C38	4.7 μ F	MLCC capacitor, 50V	1206	Murata	GRM319R61H475KA12D
2	C40, C42	22nF	MLCC capacitor, 500V	1206	Kemet	C1206V223KCRCTU
1	C41	330 μ F	Electrolytic capacitor, 450V	r10mm, d30mm	Chemi-Con	EKMZ451VSN331MR30S
1	C47	4.7nF	MLCC capacitor, 50V	0603	AVX	06035C472KAT2A
1	C48	680pF	MLCC capacitor, 50V	0603	Kemet	C0603C681J5GACTU
5	C5, C7, C10, C11, C30	330 μ F	Electrolytic capacitor, 63V	r5mm, d13mm	Wurth	860080778021
2	C60, C74	1 μ F	MLCC capacitor, 50V	1206	Kemet	C1206C105K5RECTU
2	C62, C63	22pF	MLCC capacitor, 200V	0603	Kemet	C0603C220J2GACTU
1	C69	2.2nF	MLCC capacitor, 50V	1206	Kemet	C1206C222K5RACTU
2	C8, C13	220pF	MLCC capacitor, 1000V	1206	Multicomp	MC1206B221K102CT
1	C9	33nF	Film capacitor, 630V _{DC}	r22.5mm (26.5mmx16mm)	Kemet	R73QN23304030J

Qty	Ref	Value	Description	Package	Manufacturer	Manufacturer PN
4	CY1, CY3, CY8, CY11	4.7nF	CY capacitor	r7.5mm	Kemet	C947U472MZVDBA7317
5	CY2, CY4, CY5, CY6, CY10	10nF	CY capacitor	r7.5mm	Kemet	C981U103MZVDBA7317
7	D1, D2, D3, D5, D10, D11, D23	75V	Signal diode, 100mA	SOD-23F	On Semiconductor	1N4148WS
1	D13	150V	Signal diode, 3A	DO- 214AC	Diodes, Inc.	STPS3150U
1	D21	650V	Signal diode, 8A	TO-263	Royal Ohm	SCS308AJTLL
1	D22	600V	Diode bridge, 15A	GSIB15	Vishay Semiconductors	GSIB1560-E3/45
1	D26	80V	Signal diode, 1A	DO- 214AC	Diodes, Inc.	B180-13-F
3	U7, U10, U11	2.495V	Voltage reference, 1%, 36V	SOT-23-5	TI	TL431IDBVT
2	D6, D18	2.2V	Signal diode, 20mA	0603	Rohm	SML-D12P8WT86C
7	D8, D12, D14, D16, D20, D24, D25	600V	Signal diode, 1A	DO- 214AC	On Semiconductor	RS1J
1	F1	15A	Input fuse, 450V	5mmx 20mm	Littelfuse	0487015MXEP
1	F2	20A	Output fuse, 80V	FKS ATO	Littelfuse	16670005202
1	HS1	105mmx 93mmx 36mm	Heatsink	Custom	Sandoval Martinez	MPS600W
1	L1	90µH	Resonant inductor	RM12	Custom	
1	L2	300µH	PFC inductor	35mmx 25mm	Custom	
1	L3	2 x 11.4mH	Input CM filter, 10A	R6166	VAC	T60405-R6166-X210
1	L4	100µH	Input DM filter, 6A		Würth	7447070
1	L6	2 x 11.7mH	Out CM filter, 12A	R6166	VAC	T60405-R6166-X035
4	Q1, Q2, Q3, Q3A	650V	LLC MOSFET, 31.2A, 99mΩ	TO-263	Infineon	IPB65R110CFDAATMA1
4	Q1, Q2, Q3, Q3A	650V	PFC MOSFET, 31.2A, 99mΩ	TO-263	Infineon	IPB65R110CFDAATMA1
4	Q4, Q5, Q6, Q7	120V	SR MOSFET, 10A, 31mΩ	PQFN-8	Infineon	IRFH5015TRPBF
1	Q8	20V	Sig P-channel MOSFET, 0.9A	SOT-23-3	Diodes, Inc.	ZXM61P02F
1	R1	30Ω	NTC	MS15	Ametherm	MS1530004

Qty	Ref	Value	Description	Package	Manufacturer	Manufacturer PN
6	R3, R9, R10, R16, R18, R24	0Ω	Thin film resistor	0603	Vishay	CRCW06030000Z0EA
8	R2, R11, R12, R17, R20, R21, R42, R85	100kΩ	Thin film resistor	0603	TE Connectivity	CRGCQ0603F100K
1	R13	2kΩ	Thin film resistor	1206	TT Electronics	WCR1206-2KFI
2	R14, R14A	20Ω	Thin film resistor	1206	Yageo	RC1206JR-0720RL
10	R5, R19, R26, R33, R40, R44, R48, R48A, R102, R103	10kΩ	Thin film resistor	0603	TE Connectivity	CRGCQ0603J10K
1	R28	120kΩ	Thin film resistor	0603	Yageo	RC0603FR-07120KL
1	R22	39kΩ	Thin film resistor	0603	TE Connectivity	CRGCQ0603F39K
2	R23, R41	51kΩ	Thin film resistor	0603	Vishay	CRCW060351K0FKEA
1	R27	2Ω	Thin film resistor, 600mW	MRS25	Vishay	MRS25000C2008FCT00
1	R30	220kΩ	Thin film resistor	0603	TE Connectivity	CRGCQ0603F220K
7	R34, R46, R46A, R57, R60, R64, R64A	10Ω	Thin film resistor	0603	Vishay	CRCW060310R0FKEA
6	R31, R32, R35, R36, R81, R83	2kΩ	Thin film resistor	0603	Vishay	CRCW06032K00FKEA
1	R4	510Ω	Thin film resistor	0603	Vishay	CRCW0603510RFKEA
1	R96	0Ω	Thin film resistor	0603	Yageo	RC0603FR-070RL
1	R43	1kΩ	Thin film resistor	0603	Vishay	CRCW06031K00FKEA
4	R45, R49, R54, R56	3.9MΩ	Thin film resistor	1206	Yageo	RC1206FR-073M9L
2	R52, R59	2.43MΩ	Thin film resistor	1206	Yageo	RC1206FR-072M43L
4	R50, R51, R72, R73	33mΩ	Thin film resistor	2818	Vishay	WSHM2818R0330FEB
1	R53	5.1kΩ	Thin film resistor	1206	TT Electronics	WCR1206-5K1FI
1	R55	100Ω	Thin film resistor	0603	Vishay	CRCW0603100RFKEA
2	R58, R63	33kΩ	Thin film resistor	0603	Yageo	AC0603FR-0733KL
2	R6, R6A	20mΩ	Thin film resistor	2512	Ohmite	PCS2512DR0200ET
1	R65	62kΩ	Thin film resistor	0603	Vishay	CRCW060362K0FKEA
1	R7	36Ω	Thin film resistor	1206	Multicomp	MCWR12X36R0FTL
1	R92	150kΩ	Thin film resistor	1206	TE Connectivity	CRGCQ1206F150K
1	R93	20Ω	Thin film resistor	1206	Vishay	CRCW120620R0FKEA
2	R67, R94	1kΩ	Thin film resistor	0603	Yageo	RC0603JR-071KL

Qty	Ref	Value	Description	Package	Manufacturer	Manufacturer PN
1	RL1	12V _{DC} , 30A	Thin film resistor	TA9	TE Connectivity	T9AS1D12-12
5	SK1, SK2, SK3, SK4, SK5	6mm	Screw, 6mm	M3	Keystone	9191-4
6	SP1, SP1A, SP2, SP2A, SP3, SP3A	1.6W/mK	Insulator	-	Bergquist	HF300P-0.001-00-0404
1	TR1	150μH	LLC transformer, 3:1:1	RM14	MPS	RM14 - TR1
1	TR2	8.6mH	FB transformer, 4.5:1	EF20	MPS	EF20 - TR2
1	U1	700V	FB controller, 4.5Ω	SOIC-8	MPS	HF500-15
2	U2, U4	50mA	Optocoupler, 5000V	SMD-4	On Semiconductor	FOD817A3SD
1	VAR1	460V _{AC}	Varistor	Disc, 20mm	EPCOS	B72220S0461K101
1	R38	20KΩ	Resistor	0603	Yageo	RC0603FR-0720KL
1	R61	9.53kΩ	Resistor	0603	Yageo	RC0603FR-079K53L
2	R62, R66	0Ω	Resistor	1206	Yageo	RC1206JR-070RL
1	R68	3.9Ω	Resistor	1206	Vishay Dale	CRCW12063R90 FKEAHP
1	R74	100kΩ	NTC resistor	1206	VISHAY	NTHS1206N17N 1003JE
1	RL2	12V	Relay, 10A	SPST-NO	TE Connectivity	OJ-SH-112HM,000
1	SW1	500mA	Switch, 2-position	WS-SLTV	Würth	450301014042
1	U6	Current sensor	High-Side Current- Sense Amplifier	TSOT23- 6L	Monolithic Power Systems	MPQ8112GJ-AEC1-Z
1	C50	1nF 50V	100nF	0603	KEMET	C0603X102K5RACTU
2	FAN1, FAN2	0.2m ³ /min	Fan	35mmx 35mm	Sunon	MF35101V1-1000U- A99
2	J1, J6	50A	Connector	M3	Würth Electronics	74650073R
1	J2	10A	Connector, 250V, 10A, IEC 14	30.25mmx 22.48mm	Bulgin	PX0580/PC
2	J3, J4	3A	Connector, 2-position	2.5mm	JST	B2B-XH-A(LF)(SN)
1	U3	HR1211	Combo controller	SOIC-20	MPS	HR1211GY
1	U8	MP6924	SR controller	SOIC-8	MPS	MP6924GS

3.9 Inductive Components

MPS		INDUCTIVE COMPONENT				CODE	CH600-TR1							
						DESIGNER	O. COS							
MATERIALS LIST														
Quantity	Units	Description	Manufacturer Information											
1	-	RM14 coil former	TDK: B65888C1512T001 / FERROXCUBE: CPV-RM14/I-1S-12PD or equivalent (ProdinFerrite: 210451)											
2	-	½ core RM14	TDK: B65887E0000R097 / FERROXCUBE: RM14/I-3C90 / DMEGC: DMR47 or equivalent (ProdinFerrite: 301135)											
1670	mm	Litz 50 x 0.2mm (Class F, poly.)	ProdinFerrite: V00905											
505	mm	Insulating tube (Yellow)	Royal Diamond: Royaflex F											
-	mm	Polyester film tape 60um	3M: 1350-1 T1350Y19											
0.24	mm	Gap	2 tape per leg											
WINDINGS		Turns	WIRE			PINOUT		TUBE		INSULATORS		ELECTRIC		
#	Start		Finish	∅	Class	Color	Start	End	Start	End	Layers	Mater.	Ω	uH
B1a	1S	-	6	Litz 50x0.2	-	-	A	-	Yes	Yes	3	Tape	-	-
B3	2S	5F	4	Litz 50x0.2	-	-	E	D	No	No	-	-	-	-
B2	3S	4F	4	Litz 50x0.2	-	-	D	C	No	No	3	Tape	-	-
B1b	-	6F	6	Litz 50x0.2	-	-	-	B	Yes	Yes	1	Tape	-	130
ELECTRIC SCHEME			BOTTOM VIEW			MANUFACTURING NOTES								
						<p>Lengths [mm]:</p> <ul style="list-style-type: none"> B1 = 930 B2/B3 = 370 T1 = 125 T2 = 195 T3 = 185 <p>- Cut all pins and plastic of the coil former.</p> <p>- Wind B2 and B3 in the same layer.</p> <p>- Use tape to fix the ferrite core instead of a metal clip.</p> <p>- All windings end up flying without any pin.</p> <p>- Leave 15mm of wire on each terminal, below the coil.</p> <p>- Tin 5mm of each terminal.</p> <p>- Varnish the component.</p> <p>- See details in following pages.</p>								
ASSEMBLY DETAILS			WINDOW VIEW											
VERIFICATION														
Inductance			B1 = 130 μH (±10%)											

Figure 11: LLC Resonant Converter (Transformer)

MPS	INDUCTIVE COMPONENT	CODE	CH600-L1
		DESIGNER	O. COS

MATERIALS LIST			
Quantity	Units	Description	Manufacturer Information
1	-	RM12 coil former	TDK: B65816C1512T001 / FERROXCUBE: CPV-RM12/I-1S-12PD ProdinFerrite: 210742
2	-	½ core RM12	TDK: B65815E0000R097 / FERROXCUBE: RM12/I-3C90 / DMEGC: DMR47 ProdinFerrite: 301442
-	mm	Litz 50 x 0.2mm (Class F, poly.)	ProdinFerrite: V00905
-	mm	Polyester film tape 60um	3M: 1350-1 T1350Y19
0.9	mm	Gap	

#	WINDINGS		Turns	WIRE			PINOUT		TUBE		INSULATORS		ELECTRIC	
	Start	Finish		Ø	Class	Color	Start	End	Start	End	Layers	Mater.	Ω	uH
B1	1S	2F	19	Litz 50x0.2	-	-	A	B	No	No	1	Tape	-	90

<p>ELECTRIC SCHEME</p>	<p>BOTTOM VIEW</p>	<p>MANUFACTURING NOTES</p> <ul style="list-style-type: none"> - Cut all pins and plastic except pin 9. - Use tape to fix the ferrite core instead of a metal clip. - B1 end up flying without any pin. - Leave 15mm of wire on each terminal, below the coil. - Tin 5mm of each terminal. - Varnish the component. - See details in following pages.
<p>ASSEMBLY DETAILS</p>	<p>WINDOW VIEW</p>	

VERIFICATION	
Inductance	B1 = 90 µH (±10%)

Figure 12: LLC Resonant Converter (Resonant Inductor)

MPS	INDUCTIVE COMPONENT	CODE	CH600-L2
		DESIGNER	R. COLLADO

MATERIALS LIST			
Quantity	Units	Description	Manufacturer Information
3	-	CM330 125	Chang Sung: CM 330 125 G (ProdinFerrite: 300366)
-	mm	Copper wire 1.5 mm	RSPro: 357-788
-	mm	Polyester film tape 60um	3M: 1350-1 T1350Y19

WINDINGS			Turns	WIRE			PINOUT		TUBE		INSULATORS		ELECTRIC	
#	Start	Finish		Ø	Class	Color	Start	End	Start	End	Layers	Mater.	Ω	uH
B1	1S	2F	27	Copper wire 1	-	1	2	No	No	1	Tape	-	338	

<p>ELECTRIC SCHEME</p>	<p>BOTTOM VIEW</p>	<p>MANUFACTURING NOTES</p> <ul style="list-style-type: none"> - See details in following pages. - Leave 3cm of tinned copper at the end of each leg. - B1 winding end with a flying wire. Follow assembly details as reference.
<p>ASSEMBLY DETAILS</p>		

VERIFICATION	
Inductance	B1 = 338 μH (±20%)

Figure 13: PFC Inductor

MPS	INDUCTIVE COMPONENT	CODE	CH600-TR2
		DESIGNER	O. COS

MATERIALS LIST			
Quantity	Units	Description	Manufacturer Information
1	-	E 20/10/6 Vertical coil former	TDK: B66206B1110T001 or equivalent (ProdinFerrite: 210813)
2	-	½ core E 20/10/6	TDK: B66311G0000X197 or equivalent (ProdinFerrite: 301481)
-	mm	Copper Wire Enameled 0.2mm	-
-	mm	Copper Wire Enameled 0.3mm	-
-	mm	Insulating tube (White)	-
-	mm	Polyester film tape 60um	-
0.36	mm	Gap	-

#	WINDINGS		Turns	WIRE			PINOUT		TUBE		INSULATORS		ELECTRIC	
	Start	Finish		∅	Class	Color	Start	End	Start	End	Layers	Mater.	Ω	mH
B1	1S	-	100	Copper wire 0.2	-	-	1	-	Yes	Yes	3	Tape	-	-
B5	2S	3F	20	Copper wire 0.3	-	-	9	6	Yes	Yes	-	-	-	-
B4	4S	5F	26	Copper wire 0.3	-	-	6	10	Yes	Yes	3	Tape	-	-
B1	-	6F	155	Copper wire 0.2	-	-	-	3	Yes	Yes	1	Tape	-	8.6
B2	7S	8F	57	Copper wire 0.2	-	-	4	5	Yes	Yes	-	-	-	-
B3	9S	10F	33	Copper wire 0.2	-	-	5	2	Yes	Yes	1	Tape	-	-

<p>ELECTRIC SCHEME</p>	<p>BOTTOM VIEW</p>	<p>MANUFACTURING NOTES</p> <p>- Cut pin 7 and 8.</p>
<p>ASSEMBLY DETAILS</p>	<p>WINDOW VIEW</p>	

VERIFICATION	
Inductance	B1 = 8.6 mH (±10%)

Figure 14: Flyback Converter Transformer

3.10 Mechanical Components

Table 5: Heatsink Properties

Parameter	Specification
Material	Aluminium
Thickness	2mm
Dissipation surface area	32000mm ²
Temperature under nominal conditions	52.1°C

The system must have a minimum airflow (from the back of the circuit) when it operates at full power continuously. Figure 15 shows the heatsink.

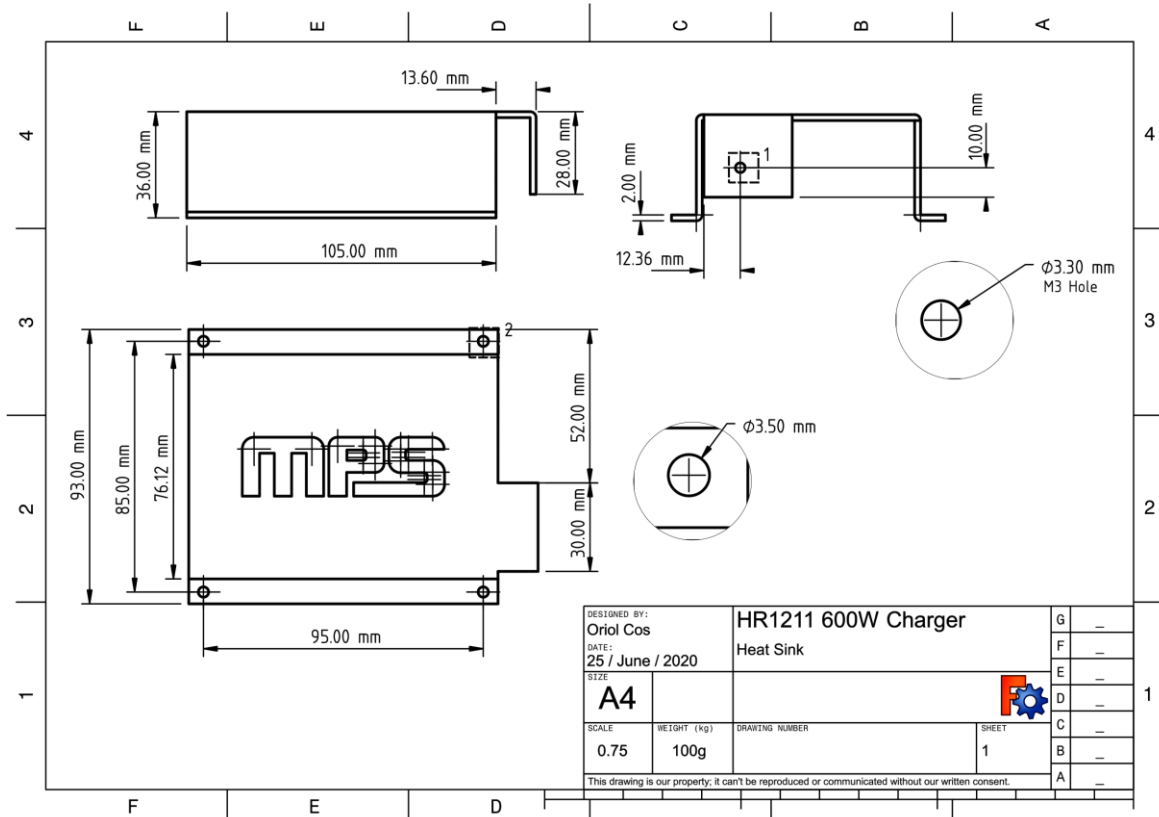

Figure 15: Heatsink

Figure 16 shows the details at the junction between the PCB and heatsink.

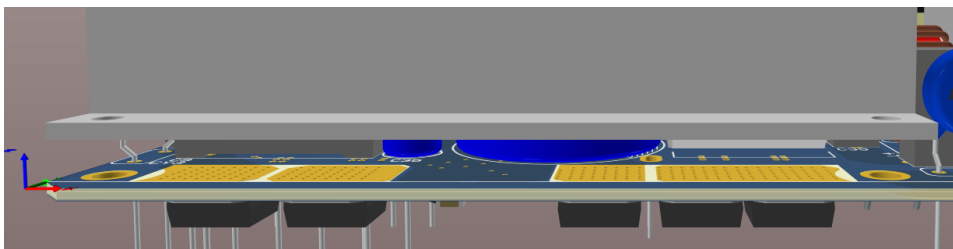

Figure 16: PCB to Heatsink Junction Details

3.11 PCB Layout Guidelines

Efficient performance in power converter systems depends mainly on the PCB design. In most cases, following generic rules is sufficient. However, the implementation of special components requires additional precautions.

For example, this design uses a PFC + LLC combo controller. This means that the designer must consider sensing and driving signals. The designer must also focus on the input PFC current and voltage, as well as the resonant capacitor voltage. For sensing traces, it is recommended to use differential pairs to reduce magnetic coupling and to avoid sharing high di/dt traces with low-voltage signals. The same principle applies to MOSFET driving signals. Lastly, the designer must ensure that no GND loops are created while using differential pairs.

The flyback controller handles high-to-low voltage conversion in a small space, so it is important to consider the component clearance. This ensures that the system is not at risk of electrical arc damage, and that the system is compliant with dielectric strength standards.

For sensing circuitry in the secondary side, always maintain a solid GND plane under the components. This plane acts as a shield for electromagnetic interference (EMI), maintaining the signals with a low noise level.

For general AC/DC designs, refer to Figure 17, Figure 18, Figure 19, and Figure 20, and follow the guidelines below:

1. Keep a 3mm isolation space between the N and L traces to ground.
2. Keep a 6mm isolation space between primary side and secondary side traces.
3. Do not place copper planes under the CM or DM filters.
4. If more than one CM filter is used, place the filters 90° from each other to avoid cross-talk and increase effectiveness.
5. Reduce high dV/dt (e.g. PFC and LLC switch nodes) areas.
6. Reduce di/dt loops (e.g. output rectification).
7. Place decoupling capacitors ($>100nF$) near the ICs.
8. Connect the power ground and signal ground at a single point near the bulk capacitor.
9. Use traces with appropriate widths. The AC and high-voltage traces should be narrow, while the DC and low-voltage traces should be wide (about 1A/mm).

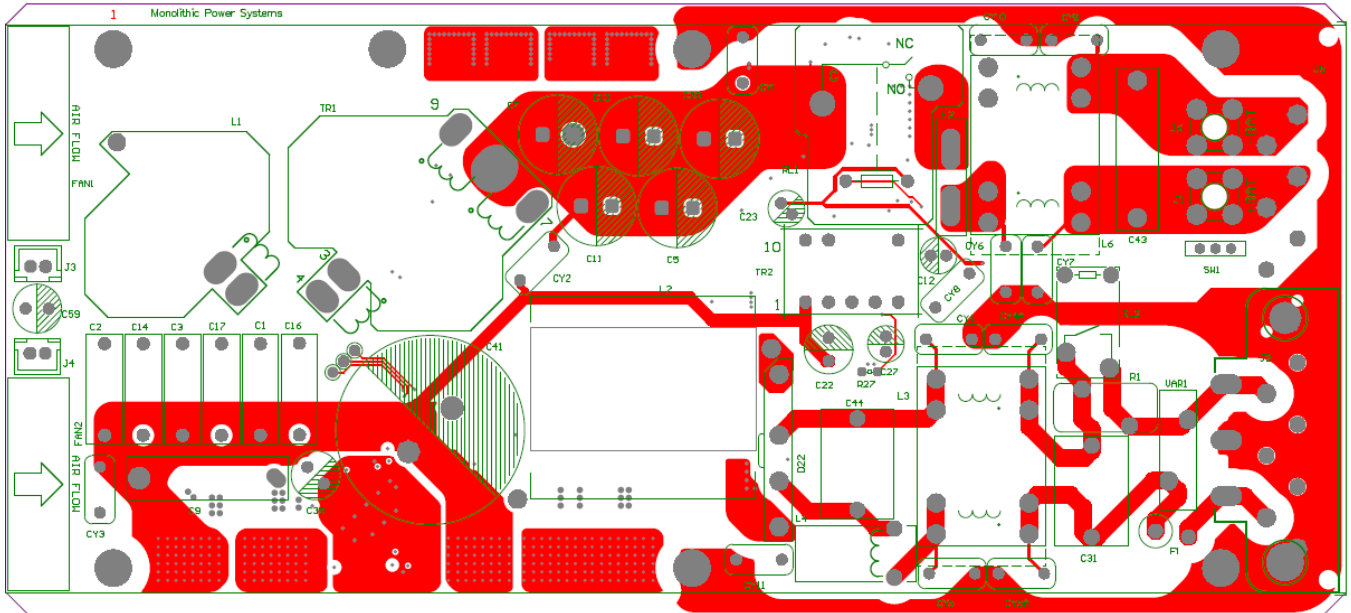

Figure 17: Top Layer

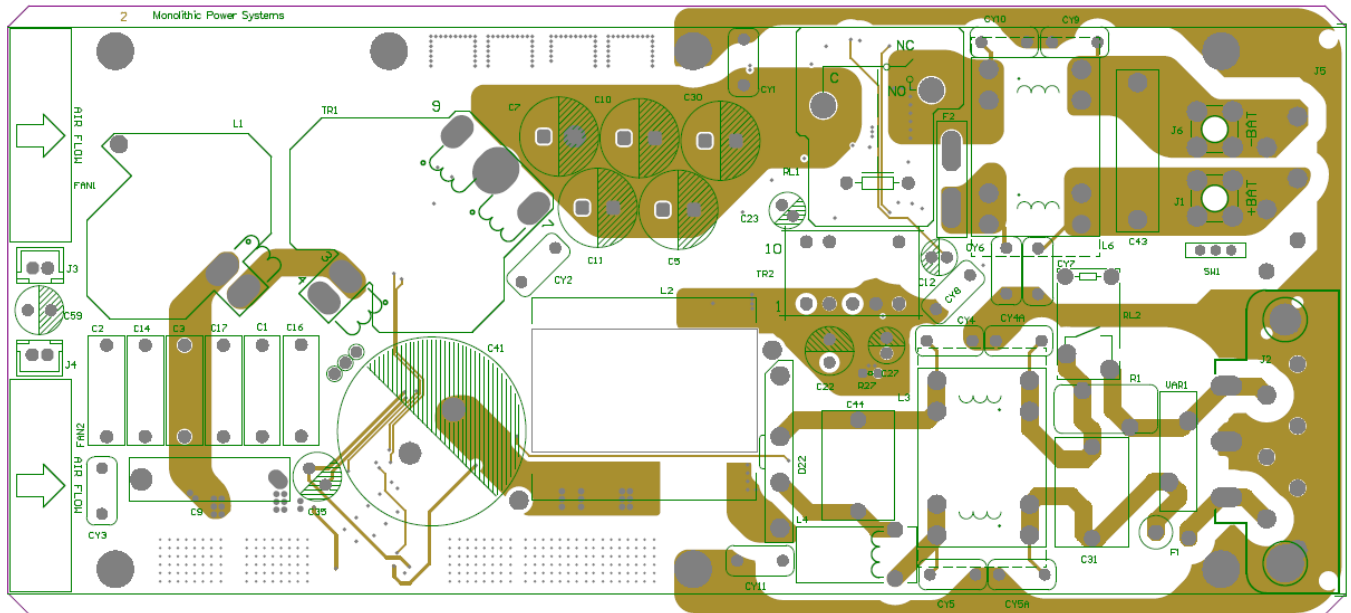

Figure 18: Layer 1

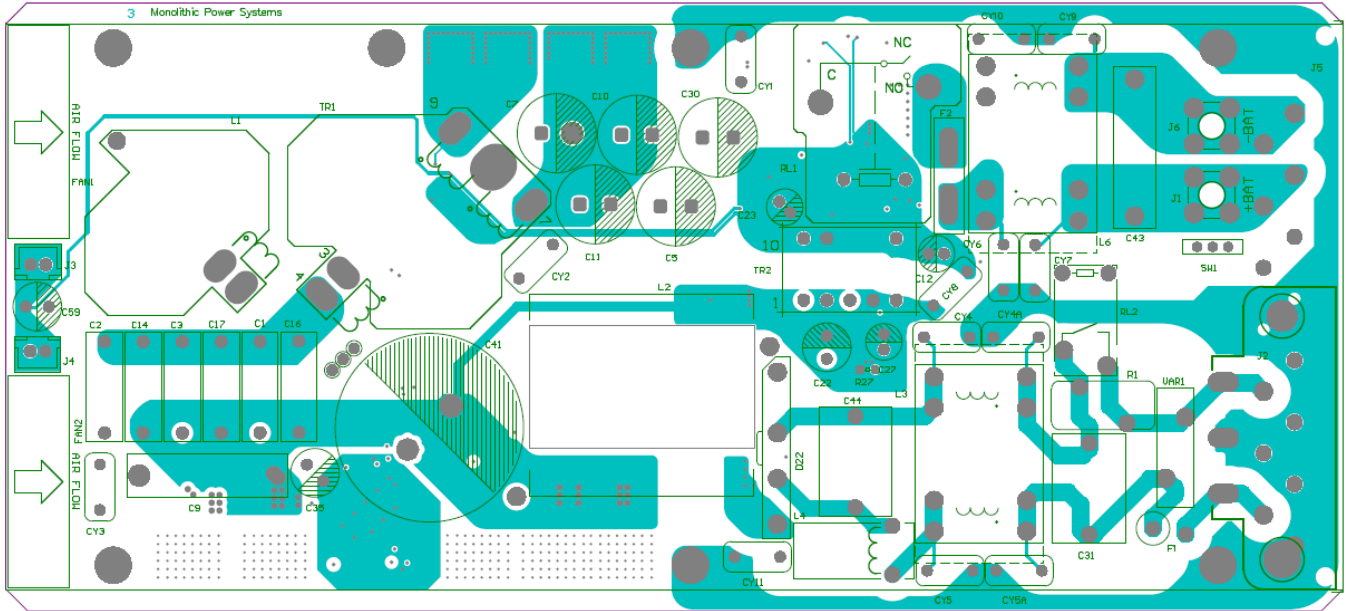

Figure 19: Layer 2

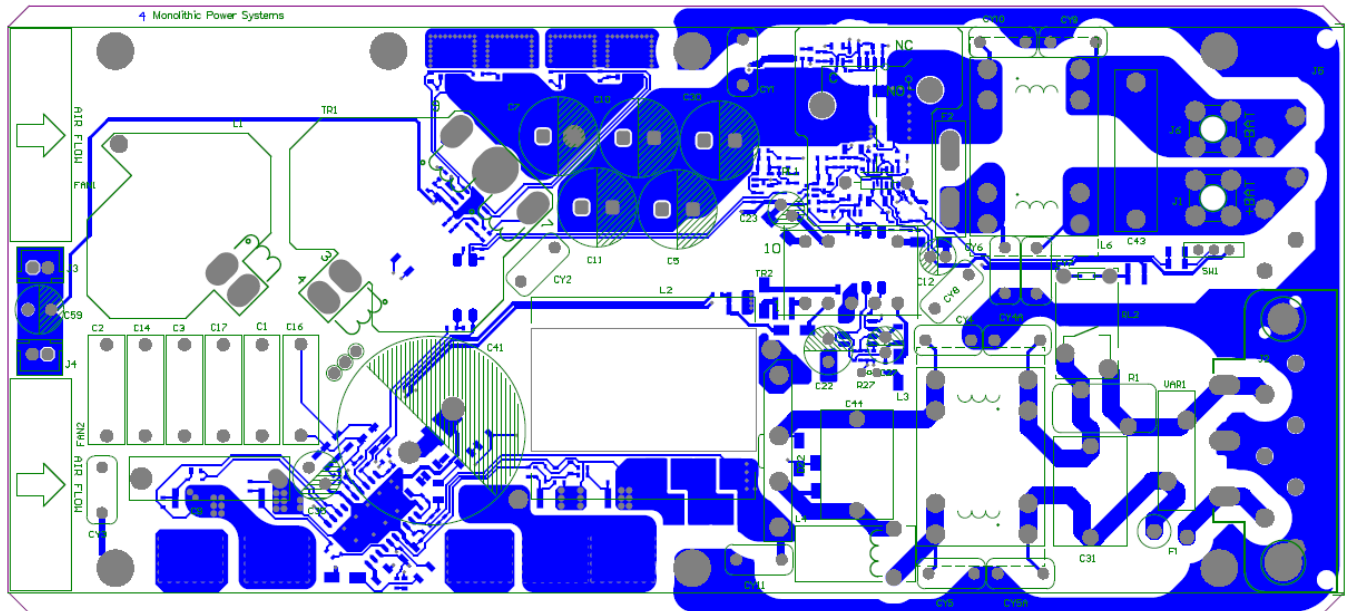

Figure 20: Bottom Layer

4 Hardware Start-Up Procedure

Figure 21 shows how to connect the evaluation board to an AC power supply and the battery. With this set-up, the user can test and verify the performance of the system.

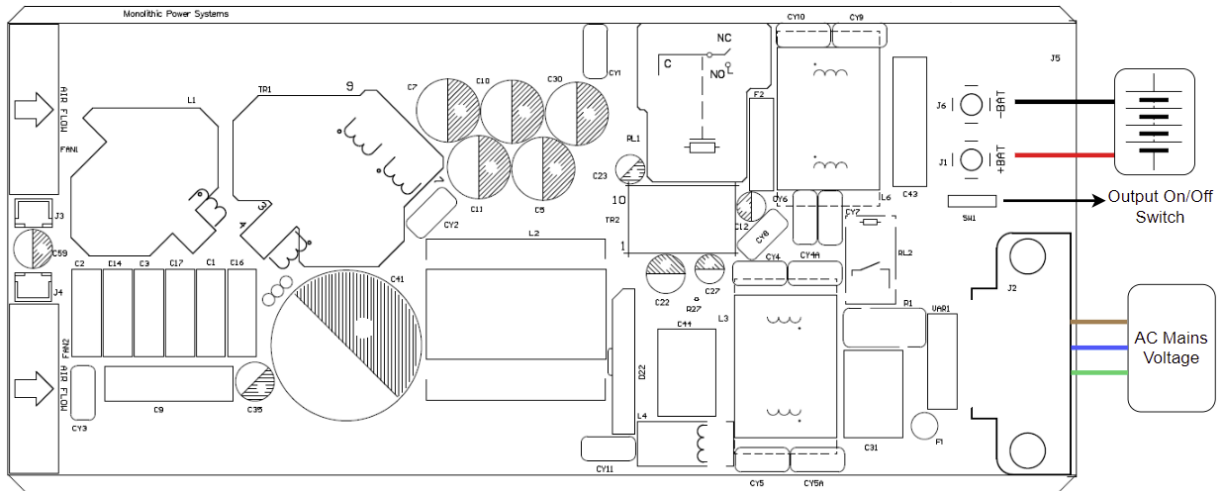

Figure 21: Connection Diagram

Table 6: Pin Out

Connector	Reference	Description
J2	Live, Neutral and Earth	AC Mains voltage
J1	+Bat	Positive output port for the battery connection.
J6	-Bat	Negative output port for the battery connection.

4.1 Test Equipment

Table 7: Test Equipment

Equipment	Description	Manufacturer	Model
AC source	Configurable AC source	Chroma	61604
Electronic load	0V to 500V and 0A to 90A	EA	EA-ELR 9500-90
Multimeter	True RMS multimeter	Fluke	179
Oscilloscope	5GSa/s, 10-bit ADC	Rohde & Schwarz	RTM3004
Voltage probe	3.5pF, 100MHz, ±1400V (isolated)	Rohde & Schwarz	RT-ZD01
Voltage probe	7.5pF, 1 MHz, 1000V	Rohde & Schwarz	RT-ZH10
Current probe	100mV/A, 50MHz, 30Arms (DC + AC)	Rohde & Schwarz	RT-ZC155
Current probe	20mV/A, 30MHz, 300Apk (AC)	CWT	PEM Rogowski
Power meter	Evaluate efficiency and PF	Yokogawa	WT332E
Thermal camera	-	FLIR	E6 Wi-Fi
Spectrum analyzer	5kHz to 3GHz	Rohde & Schwarz	FPC1500
LISN	150kHz to 30 MHz	Rohde & Schwarz	HM6050-2

4.2 System Power-Up

The following procedure ensures that the evaluation board starts up properly. Note that there are exposed high-voltage AC and DC pads. Do not touch the circuit board while the system is operating, the AC source is disconnected, or the D6 or D18 LEDs are shining.

1. Connect the equipment (see Figure 22). The battery can be replaced with an electronic load.
2. Set the electronic load to either constant current (CC) or constant voltage (CV) mode.
3. Set the AC voltage source between 85V_{AC} and 265V_{AC}.
4. Turn on the AC source.
5. Verify that the D6 and D18 LEDs are shining.
6. Use the multimeter to verify that the output voltage (before the relay) is within the specified range.
7. Close the contact between J1.12 and J1.14 (turn on the relay).
8. Turn on the electronic load. Set the load from 58.8V to 30V in CV mode, or set the load from 0A to 9.5A in CC mode.

4.3 Signal Measurements

Figure 22 and Table 8 show how to properly measure the signal to test charger performance.

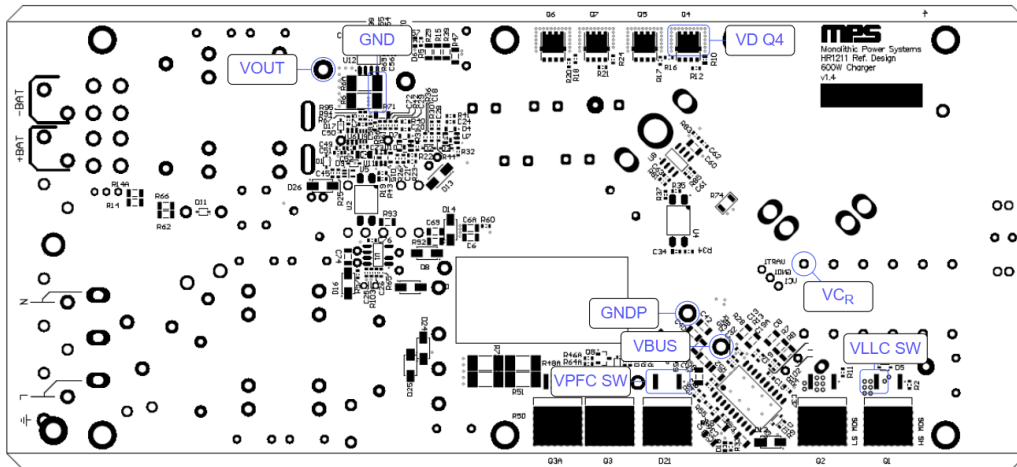

Figure 22: Signal Diagram

Table 8: Signal Description

Signal	Voltage Range	Description
VPFC SW	0V _{DC} to 410V _{DC}	PFC stage switch node.
VBUS	0V _{DC} to 410V _{DC}	DC link between PFC and LLC stage.
GND P	0V _{DC}	Primary-side ground reference.
VLLC SW	0V _{DC} to 410V _{DC}	LLC stage switch node.
V _{CR}	-50V _{PK} to +550 V _{PK}	Resonant capacitor voltage
VD Q4	0V _{PK} to 150V _{PK}	Synchronous rectification transistor, drain voltage.
VOUT	0V _{DC} to 59.8V _{DC}	Output voltage before the relay.
GND	0V _{DC}	Secondary-side ground reference.

5 Test Results

5.1 Test Overview

Figure 23: Efficiency vs. Load

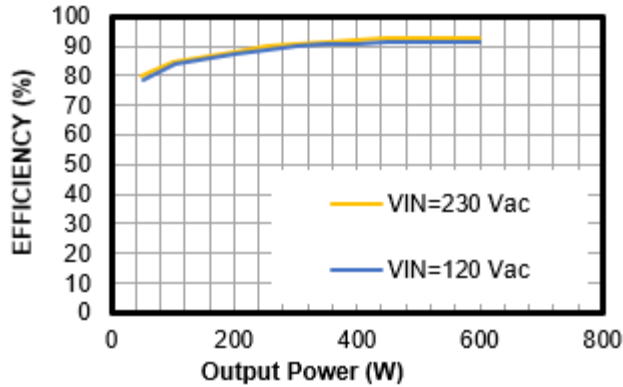

Figure 24: Efficiency vs. Input Voltage

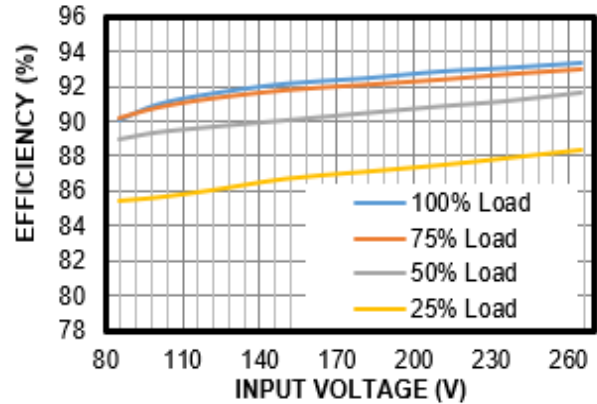

Figure 25: Output Current vs. Output Voltage

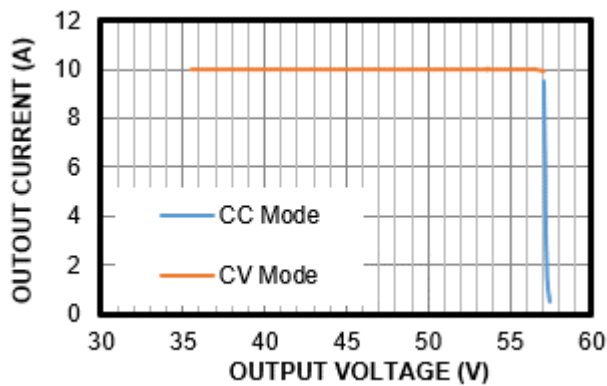

Figure 26: Power Factor

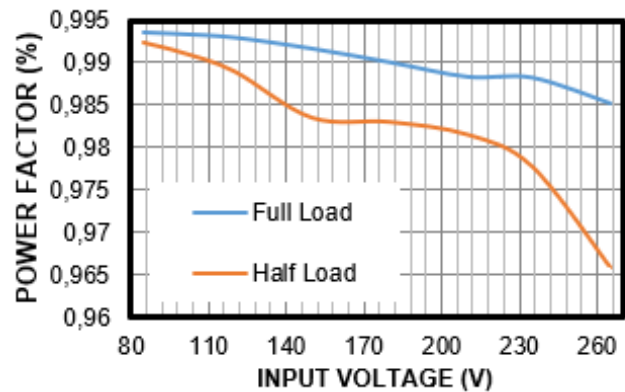

Figure 27: Current Harmonic Distribution

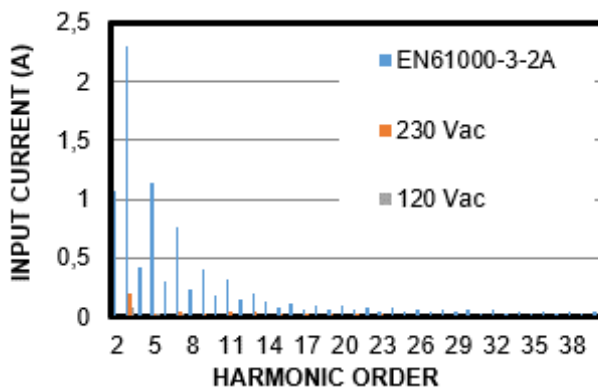

Table 9: Power Analysis Results, Harmonics (Spectrum), 49.974Hz, EN61000-3-2 A

Current: Pass
Total Pass: 33
Total Fail: 0

Order	Frequency (Hz)	Level (A)	Minimum (A)	Maximum (A)	Average (A)	Limit (A)	State
1	50.2736	2.6312	2.6252	2.6312	2.6303	16.0000	Pass
2	99.0237	0.0038	0.0004	0.0056	0.0028	1.0800	Pass
3	149.2970	0.0885	0.0861	0.0914	0.0885	2.3000	Pass
4	199.5710	0.0035	0.0018	0.0070	0.0043	0.4300	Pass
5	251.3680	0.0277	0.0242	0.0304	0.0281	1.1400	Pass
6	298.5950	0.0064	0.0010	0.0064	0.0041	0.3000	Pass
7	348.8680	0.0342	0.0308	0.0359	0.0331	0.7700	Pass
8	400.6650	0.0039	0.0026	0.0074	0.0050	0.2300	Pass
9	449.4150	0.0191	0.0154	0.0244	0.0191	0.4000	Pass
10	499.6890	0.0075	0.0016	0.0091	0.0053	0.1840	Pass
11	548.4390	0.0113	0.0071	0.0127	0.0098	0.3300	Pass
12	598.7120	0.0053	0.0015	0.0086	0.0049	0.1533	Pass
13	648.9860	0.0116	0.0096	0.0157	0.0126	0.2100	Pass
14	700.7830	0.0070	0.0012	0.0077	0.0046	0.1314	Pass
15	751.0570	0.0137	0.0113	0.0200	0.0154	0.0800	Pass
16	798.2830	0.0073	0.0008	0.0073	0.0039	0.1150	Pass
17	850.0800	0.0145	0.0143	0.0216	0.0171	0.0706	Pass
18	900.3540	0.0058	0.0016	0.0075	0.0043	0.1022	Pass
19	949.1040	0.0164	0.0134	0.0199	0.0168	0.0632	Pass
20	999.3780	0.0043	0.0010	0.0063	0.0038	0.0920	Pass
21	1049.6500	0.0172	0.0115	0.0172	0.0142	0.0571	Pass
22	1099.9200	0.0037	0.0025	0.0065	0.0044	0.0836	Pass
23	1150.2000	0.0040	0.0040	0.0094	0.0063	0.0522	Pass
24	1198.9500	0.0056	0.0019	0.0070	0.0049	0.0767	Pass
25	1250.7500	0.0013	0.0007	0.0041	0.0022	0.0480	Pass
26	1297.9700	0.0065	0.0035	0.0076	0.0055	0.0708	Pass
27	1348.2500	0.0034	0.0027	0.0066	0.0043	0.0444	Pass
28	1398.5200	0.0064	0.0031	0.0084	0.0054	0.0657	Pass
29	1448.7900	0.0055	0.0042	0.0098	0.0072	0.0414	Pass
30	1499.0700	0.0050	0.0026	0.0069	0.0048	0.0613	Pass
31	1549.3400	0.0093	0.0072	0.0124	0.0093	0.0387	Pass
32	1598.0900	0.0061	0.0004	0.0076	0.0043	0.0575	Pass
33	1648.3600	0.0097	0.0076	0.0119	0.0095	0.0364	Pass
34	1698.6400	0.0031	0.0009	0.0058	0.0032	0.0541	Pass
35	1750.4300	0.0063	0.0049	0.0086	0.0068	0.0343	Pass
36	1797.6600	0.0028	0.0005	0.0042	0.0022	0.0511	Pass
37	1849.4600	0.0038	0.0017	0.0064	0.0043	0.0324	Pass
38	1898.2100	0.0022	0.0004	0.0039	0.0019	0.0484	Pass
39	1950.0000	0.0024	0.0008	0.0057	0.0027	0.0308	Pass
40	1998.7600	0.0013	0.0004	0.0037	0.0019	0.0460	Pass

Table 10: Power Analysis Results, Harmonics (Spectrum), 59.972Hz, EN61000-3-2 A

Current: Pass
Total Pass: 224
Total Fail: 0

Order	Frequency (Hz)	Level (A)	Minimum (A)	Maximum (A)	Average (A)	Limit (A)	State
1	59.4142	5.1780	5.1780	5.2259	5.1923	16.0000	Pass
2	120.3520	0.0043	0.0014	0.0182	0.0057	1.0800	Pass
3	179.7660	0.2001	0.1919	0.2028	0.1970	2.3000	Pass
4	239.1800	0.0065	0.0005	0.0065	0.0028	0.4300	Pass
5	300.1180	0.0380	0.0296	0.0380	0.0346	1.1400	Pass
6	361.0560	0.0038	0.0002	0.0045	0.0025	0.3000	Pass
7	420.4700	0.0406	0.0270	0.0406	0.0324	0.7700	Pass
8	478.3610	0.0031	0.0008	0.0063	0.0030	0.2300	Pass
9	539.2980	0.0398	0.0297	0.0403	0.0358	0.4000	Pass
10	600.2360	0.0072	0.0013	0.0072	0.0032	0.1840	Pass
11	659.6500	0.0408	0.0323	0.0420	0.0380	0.3300	Pass
12	719.0640	0.0036	0.0010	0.0062	0.0025	0.1533	Pass
13	780.0020	0.0430	0.0343	0.0430	0.0374	0.2100	Pass
14	840.9400	0.0059	0.0008	0.0059	0.0025	0.1314	Pass
15	900.3540	0.0379	0.0304	0.0387	0.0343	0.0800	Pass
16	958.2450	0.0047	0.0009	0.0047	0.0023	0.1150	Pass
17	1019.1800	0.0357	0.0314	0.0381	0.0340	0.0706	Pass
18	1078.6000	0.0042	0.0008	0.0045	0.0025	0.1022	Pass
19	1138.0100	0.0332	0.0270	0.0337	0.0304	0.0632	Pass
20	1198.9500	0.0040	0.0003	0.0058	0.0021	0.0920	Pass
21	1259.8900	0.0303	0.0252	0.0324	0.0291	0.0571	Pass
22	1320.8200	0.0021	0.0005	0.0041	0.0022	0.0836	Pass
23	1378.7100	0.0267	0.0227	0.0270	0.0253	0.0522	Pass
24	1438.1300	0.0010	0.0005	0.0046	0.0021	0.0767	Pass
25	1499.0700	0.0200	0.0176	0.0224	0.0194	0.0480	Pass
26	1560.0000	0.0011	0.0010	0.0038	0.0020	0.0708	Pass
27	1619.4200	0.0150	0.0108	0.0175	0.0143	0.0444	Pass
28	1678.8300	0.0022	0.0008	0.0039	0.0022	0.0657	Pass
29	1738.2500	0.0115	0.0090	0.0144	0.0113	0.0414	Pass
30	1799.1800	0.0026	0.0006	0.0042	0.0021	0.0613	Pass
31	1858.6000	0.0081	0.0050	0.0113	0.0083	0.0387	Pass
32	1918.0100	0.0025	0.0008	0.0038	0.0021	0.0575	Pass
33	1980.4700	0.0079	0.0049	0.0093	0.0070	0.0364	Pass
34	2038.3600	0.0022	0.0007	0.0044	0.0020	0.0541	Pass
35	2099.3000	0.0067	0.0037	0.0081	0.0058	0.0343	Pass
36	2158.7200	0.0040	0.0005	0.0043	0.0024	0.0511	Pass
37	2218.1300	0.0073	0.0028	0.0081	0.0055	0.0324	Pass
38	2277.5400	0.0014	0.0006	0.0039	0.0020	0.0484	Pass
39	2338.4800	0.0055	0.0012	0.0071	0.0045	0.0308	Pass
40	2397.9000	0.0027	0.0003	0.0035	0.0019	0.0460	Pass

5.2 Waveforms

The waveforms below show the correct operation of the evaluation board. If not specified, the operation conditions are nominal (see Table 2 on page 4).

Figure 28: Input Characteristics (High Line)

$V_{IN} = 230V_{AC}$, $V_{OUT} = 58.8V$, $I_{OUT} = 9.5A$

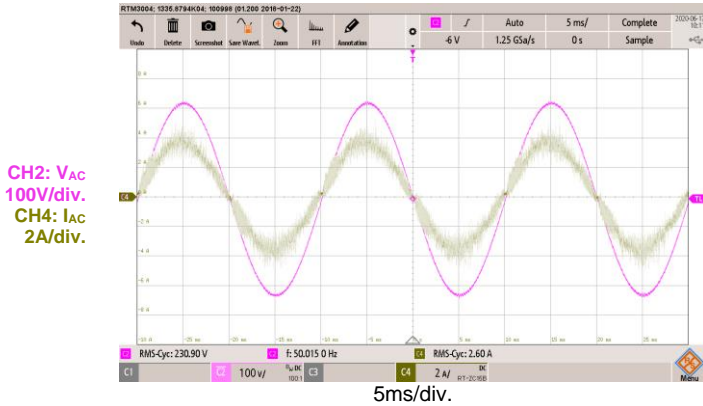

Figure 29: Input Characteristics (Low Line)

$V_{IN} = 120V_{AC}$, $V_{OUT} = 58.8V$, $I_{OUT} = 9.5A$

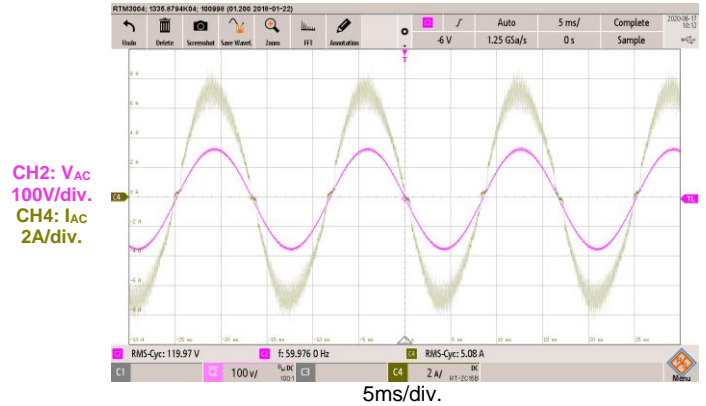

Figure 30: System Inrush Current

$V_{IN} = 265V_{AC}$, no load

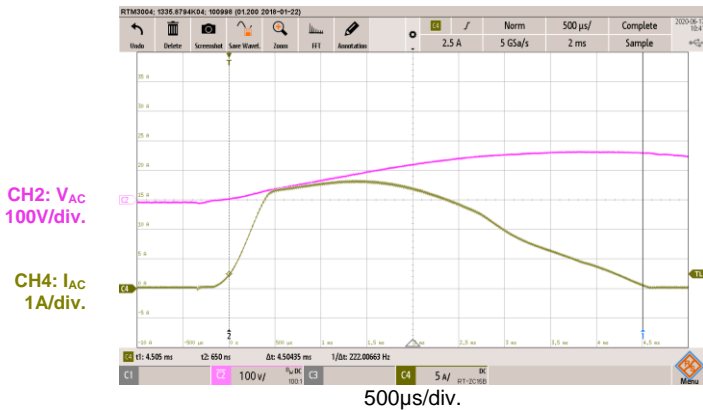

Figure 31: PFC (High Line)

$V_{IN} = 230V_{AC}$, $V_{OUT} = 58.8V$, $I_{OUT} = 9.5A$, full load

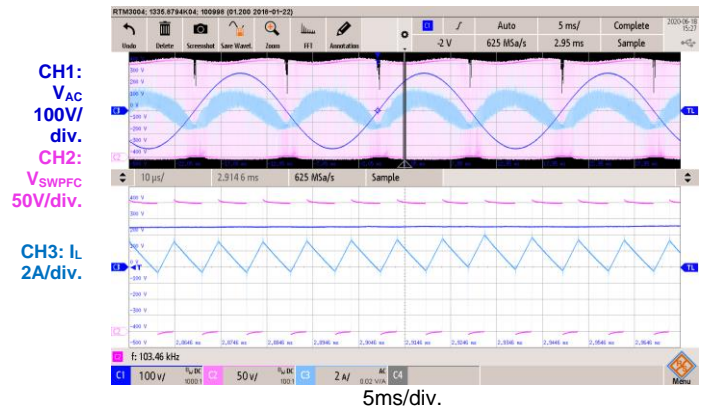

Figure 32: PFC (High Line)

$V_{IN} = 230V_{AC}$, $V_{OUT} = 58.8V$, $I_{OUT} = 5A$, half-load

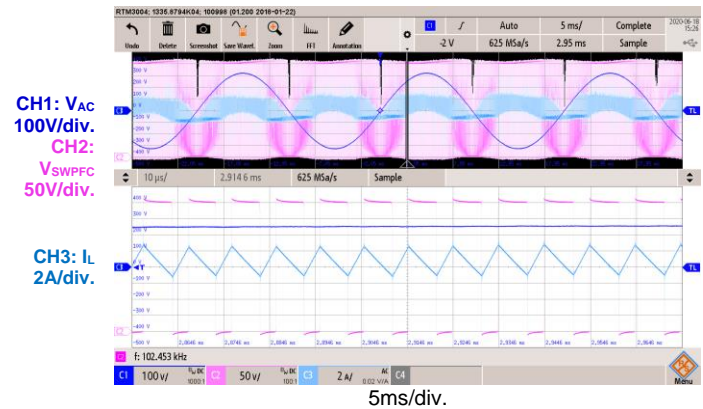

Figure 33: PFC (Low Line)

$V_{IN} = 120V_{AC}$, $V_{OUT} = 58.8V$, $I_{OUT} = 9.5A$, full load

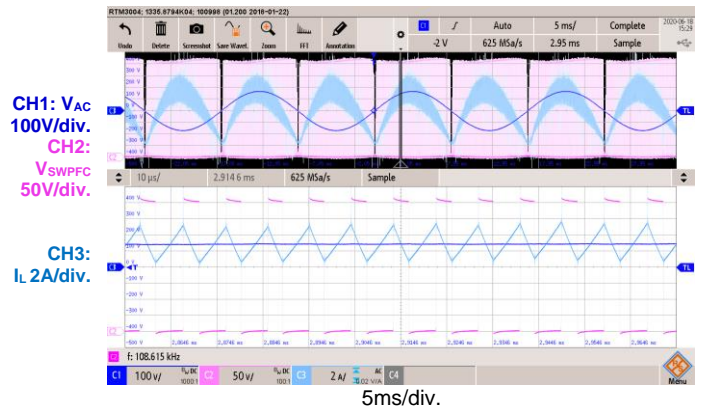

Figure 34: PFC (Low Line)

$V_{IN} = 120V_{AC}$, $V_{OUT} = 58.8V$, $I_{OUT} = 5A$, half-load

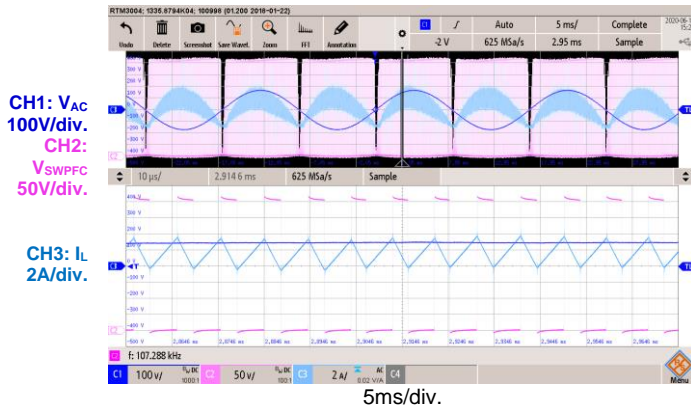

Figure 35: LLC Constant Voltage

$V_{IN} = 230V_{AC}$, $V_{OUT} = 58.8V$, $I_{OUT} = 9.5A$, full load

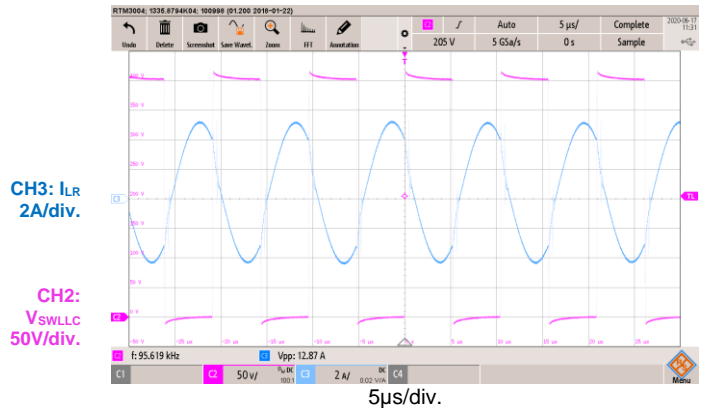

Figure 36: LLC Constant Voltage

$V_{IN} = 230V_{AC}$, $V_{OUT} = 58.8V$, $I_{OUT} = 5.5A$

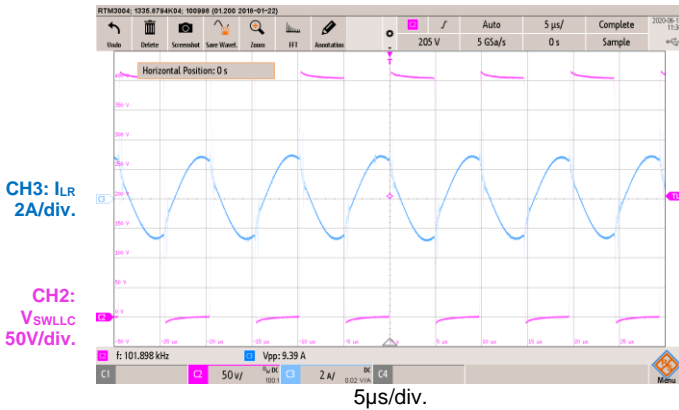

Figure 37: LLC Constant Current (57V)

$V_{IN} = 230V_{AC}$, $V_{OUT} = 57V$, $I_{OUT} = 10A$

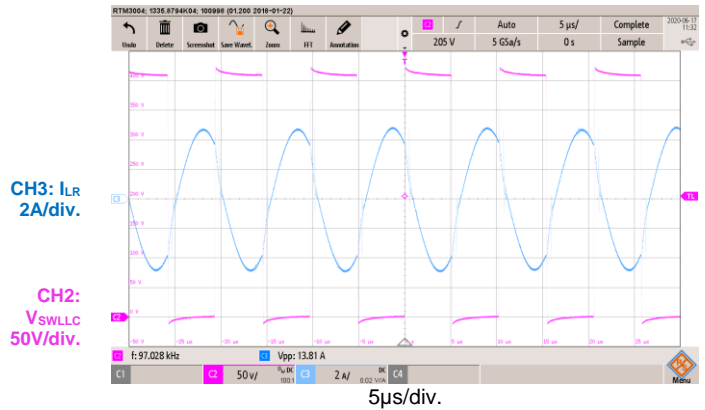

Figure 38: LLC Constant Current (35V)

$V_{IN} = 230V_{AC}$, $V_{OUT} = 35V$, $I_{OUT} = 10A$

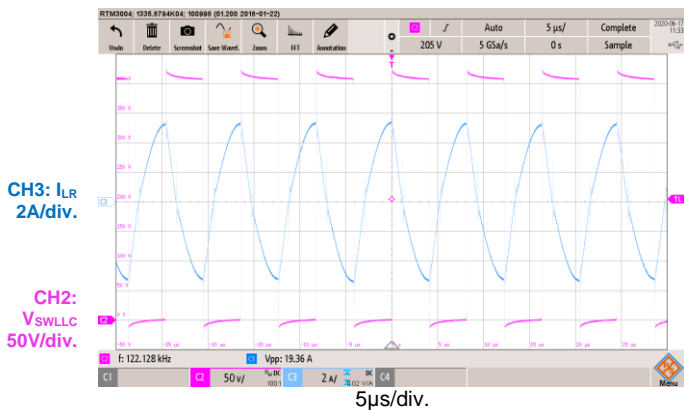

Figure 39: SR Constant Current (57V)

$V_{IN} = 230V_{AC}$, $V_{OUT} = 57V$, $I_{OUT} = 10A$

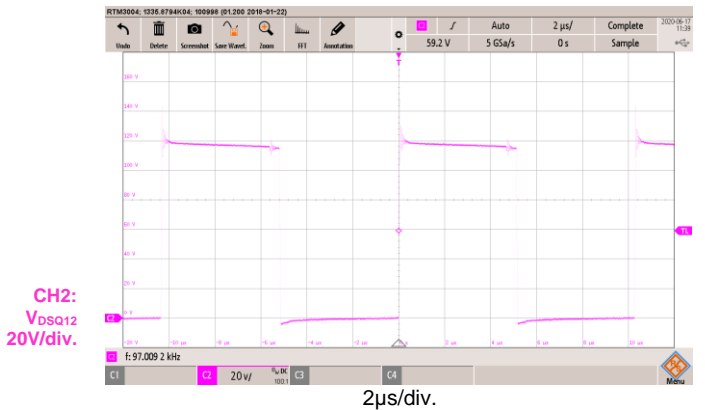

Figure 40: Voltage Ripple (CV)

$V_{IN} = 230V_{AC}$, $V_{OUT} = 58.8V$, $I_{OUT} = 9.5A$

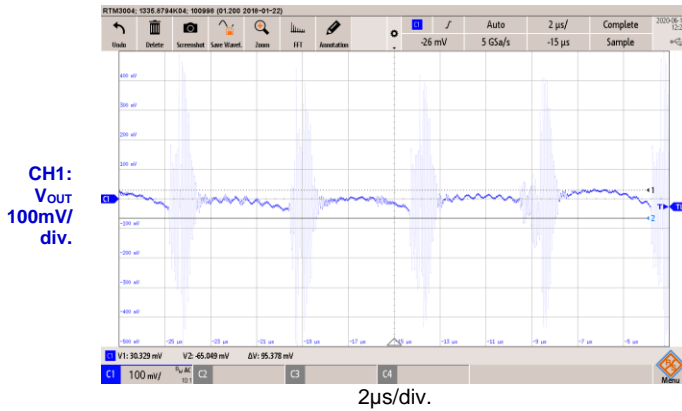

Figure 41: Current Ripple (CC)

$V_{IN} = 230V_{AC}$, $V_{OUT} = 57V$, $I_{OUT} = 10A$

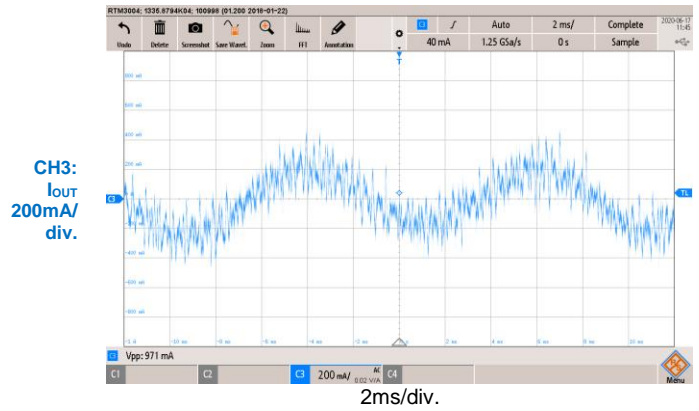

Figure 42: Load Transient (CV)

$V_{IN} = 230V_{AC}$, $V_{OUT} = 58.8V$, $I_{OUT} = 5$ to $9.5A$

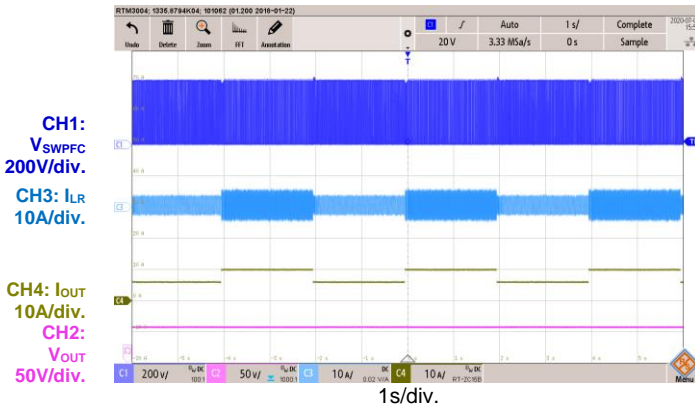

Figure 43: Load Transient (CC)

$V_{IN} = 230V_{AC}$, $V_{OUT} = 35$ to $55V$, $I_{OUT} = 10A$

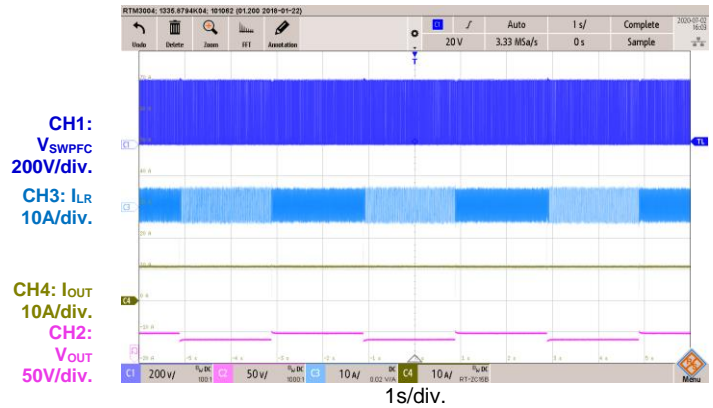

Figure 44: Start-Up

$V_{IN} = 230V_{AC}$, $V_{OUT} = 58.8V$, $I_{OUT} = 3A$

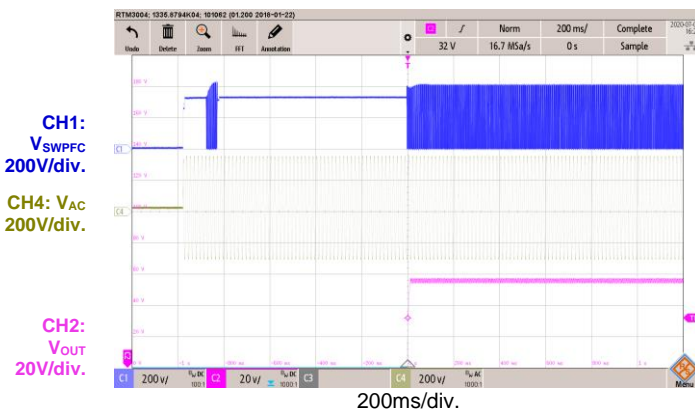

Figure 45: Shutdown

$V_{IN} = 230V_{AC}$, $V_{OUT} = 58.8V$, $I_{OUT} = 9.5A$

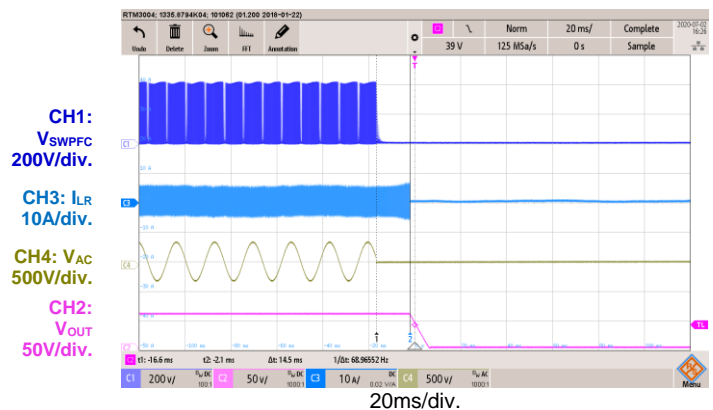
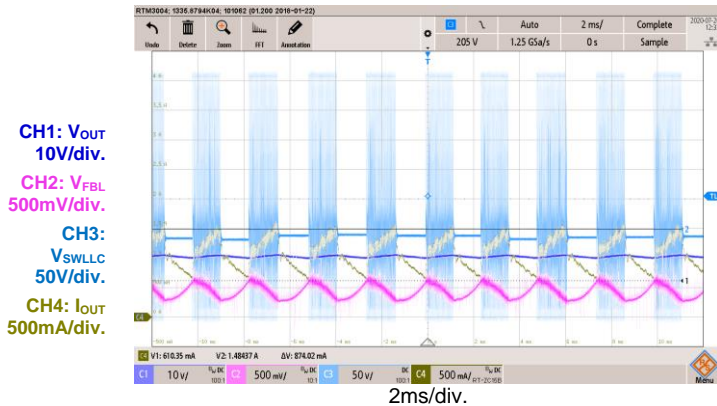

Figure 46: Trickle Charge Mode

$V_{IN} = 230V_{AC}$, $V_{OUT} = 20V$, $I_{OUT} = 1A$



Comments:

This test is performed by modifying the sense resistor ($R6$: 10m Ω to 100m Ω) to observe the behaviour of the system in trickle charge mode, when the battery recovers from a deep discharge. Because the output power is very low, the HR1211 operates in burst mode. Burst mode reduces commutation losses and improves efficiency by skipping switching periods.

5.3 Thermal Measurements

Figure 47: Thermal Imaging (Top View)

$V_{IN} = 230V_{AC}$, $V_{OUT} = 58.8V$, $I_{OUT} = 9.5A$, 25°C

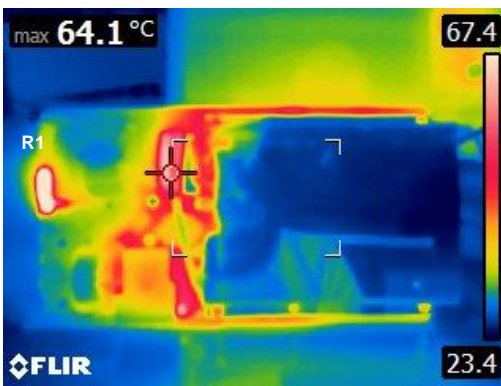
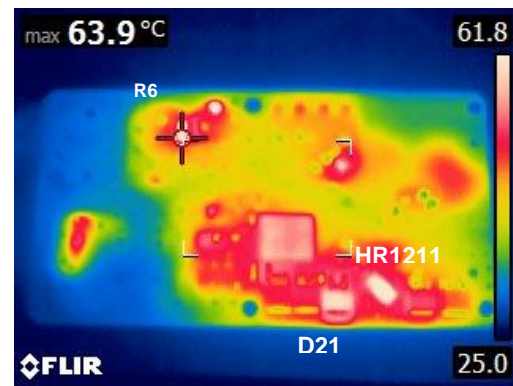

Figure 48: Thermal Imaging (Bottom View)

$V_{IN} = 230V_{AC}$, $V_{OUT} = 58.5V$, $I_{OUT} = 9.5A$, 25°C



5.4 Conducted Emissions

Figure 49: Live (Based on EN55032 Class B)
 $V_{IN} = 230V_{AC}$, $V_{OUT} = 58.8V$, $I_{OUT} = 9.5A$,
 $f_{sw_LLC} = 100kHz$, average = green, QPK = red

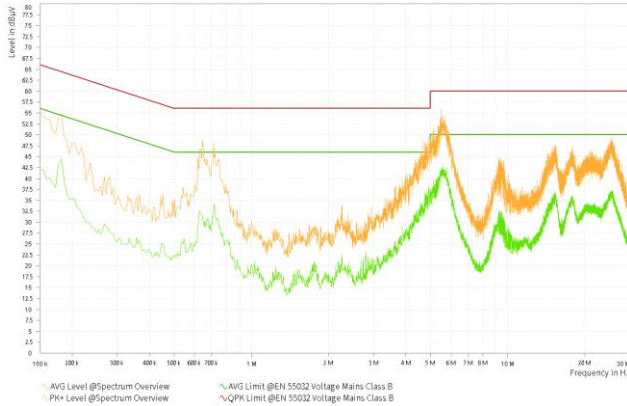

Figure 50: Neutral (Based on EN55032 Class B)
 $V_{IN} = 230V_{AC}$, $V_{OUT} = 58.8V$, $I_{OUT} = 9.5A$,
 $f_{sw_LLC} = 100kHz$, average = green, QPK = red



6 Disclaimer

Monolithic Power Systems (MPS) reserves the right to make changes to its products and to discontinue products without notice. The applications information, schematic diagrams, and other reference information included herein is provided as a design aid only and are therefore provided as-is. MPS makes no warranties with respect to this information and disclaims any implied warranties of merchantability or non-infringement of third-party intellectual property rights.

MPS cannot assume responsibility for use of any circuitry other than circuitry entirely embodied in an MPS product. No circuit patent licenses are implied.

Certain applications using semiconductor products may involve potential risks of death, personal injury, or severe property or environmental damage (“Critical Applications”).

MPS PRODUCTS ARE NOT DESIGNED, INTENDED, AUTHORIZED, OR WARRANTED TO BE SUITABLE FOR USE IN LIFE SUPPORT APPLICATIONS, DEVICES OR SYSTEMS, OR OTHER CRITICAL APPLICATIONS.

Inclusion of MPS products in critical applications is understood to be fully at the risk of the customer.

Questions concerning potential risk applications should be directed to MPS.

MPS semiconductors are typically used in power supplies in which high voltages are present during operation. High-voltage safety precautions should be observed in design and operation to minimize the chance of injury.

REVISION HISTORY

Revision #	Revision Date	Description	Pages Updated
1.0	12/4/2020	Initial Release	-
1.1	10/21/2021	Updated cover photo, Figures 7–9, Figures 12–20	1, 7, 8, 19–23
1.2	12/23/2021	Updated Figure 20	23
1.3	9/9/2022	Updated cover photo; updated pagination in the Table of Contents; updated Figure 1; updated Table 2	1–4
		Updated link in Table 1	4
		Table 3	6
		Updated Figures 7–10	7–9
		Updated Figures 13–27	16–18, 20–24
		Updated Figure 49 and Figure 50	31
		Updated footnote	33
		Updated figure titles; updated pagination; minor grammar and formatting updates	All

Notice: The information in this document is subject to change without notice. Please contact MPS for current specifications. Users should warrant and guarantee that third-party Intellectual Property rights are not infringed upon when integrating MPS products into any application. MPS will not assume any legal responsibility for any said applications.